



COLLIN COUNTY

Kitchen Equipment for Collin County Jail

IFB 2018-102

**J. D. Griffin, CPPB
Jack Hatchell Administration Building
2300 Bloomdale Road, Ste. 3160
McKinney, TX 75071**

**(P) 972-548-4116 (F) 972-548-4694
jgriffin@collincountytexas.gov**

Collin County exclusively uses IonWave Technologies, Inc. ([Collin County eBid](#)) for the notification and dissemination of all solicitations. The receipt of solicitations through any other means may result in your receipt of incomplete specifications and/or addendums which could ultimately render your bid/proposal non-compliant. Collin County accepts no responsibility for the receipt and/or notification of solicitations through any other means.

LEGAL NOTICE

By order of the Commissioners' Court of Collin County, Texas, sealed bids will be received by the Purchasing Agent, 2300 Bloomdale, Suite 3160, McKinney, TX 75071, until **2:00 P.M., Thursday, February 15, 2018**, for Invitation For Bid **Kitchen Equipment for Collin County Jail (IFB No. 2018-102)**. A **Pre-Bid Meeting** will be held **Monday, February 5, 2018 at 10:00 a.m.** at Collin County Justice Center Jail Dock, 4300 Community Ave. McKinney, TX 75071. Bidders shall use unit pricing. Funds for payment have been provided through the Collin County budget approved by the Commissioner's Court for this fiscal year only. Bidders may obtain detailed specifications and other documents at Office of the Purchasing Agent: Collin County Administration Building, 2300 Bloomdale, Suite 3160, McKinney, TX 75071, 972-548-4165, or by going to: <https://collincountytx.ionwave.net>. Sealed bids will be opened on **Thursday, February 15, 2018 at 2:00 P.M.** by the Purchasing Agent, 2300 Bloomdale, Suite 3160, McKinney, TX 75071. The Commissioners' Court reserves the right to reject any and all bids.

.....

ATTENTION:	CLASSIFIEDS
BILL TO:	ACCOUNT NO 06100315-000
	COMMISSIONER'S COURT

NOTICE TO PUBLISHERS: Please publish in your issue on **Thursday, January 25, 2018** and **Thursday, February 1, 2018**. A copy of this notice and the publisher's affidavit must accompany the invoice when presented for payment.

NEWSPAPER:	<u>Plano Star Courier</u>
DATE:	<u>January 23, 2018</u>
FAX:	<u>972-529-1684</u>

Collin County, Texas

Bid Information

Bid Owner JD Griffin, CPPB Buyer II
Email jgriffin@co.collin.tx.us
Phone (972) 548-4116
Fax (972) 548-4694

Bid Number 2018-102
Title Kitchen Equipment for Collin County Jail

Bid Type IFB
Issue Date 01/23/2018
Close Date 2/15/2018 02:00:00 PM (CT)

Contact Information

Address 2300 Bloomdale Rd.
Ste. 3160
McKinney, TX 75071

Contact JD Griffin, CPPB Buyer II
Department Purchasing
Building Admin. Building
Floor/Room Ste.3160
Telephone (972) 548-4116
Fax (972) 548-4694
Email jgriffin@co.collin.tx.us

Ship to Information

Address

Contact
Department
Building
Floor/Room
Telephone
Fax
Email

Supplier Information

Company Name _____
Contact Name _____
Address _____

Telephone _____
Fax _____
Email _____

Supplier Notes

The undersigned hereby certifies the foregoing bid submitted by the company listed below hereinafter called "bidder" is the duly authorized agent of said company and the person signing said bid has been duly authorized to execute same. Bidder affirms that they are duly authorized to execute this contract; this company; corporation, firm, partnership or individual has not prepared this bid in collusion with any other bidder or other person or persons engaged in the same line of business; and that the contents of this bid as to prices, terms and conditions of said bid have not been communicated by the undersigned nor by any employee or agent to any other person engaged in this type of business prior to the official opening of this bid.

Signature _____ Date ____ / ____ / ____

Bid Notes

Please log in to view bid documents.

Bid Activities

Date	Name	Description
2/5/2018 10:00 AM (CT)	Pre-Bid Meeting	A pre bid meeting will be held on Monday, February 5, 2018 at 10:00 A.M at the Collin County Justice Center Jail Dock located at 4300 Community, McKinney, TX 75071. All prospective bidders are requested to have a representative present. It is the bidder's responsibility to review the site and documents to gain a full understanding of the requirements of the project.
2/9/2018 05:00 PM (CT)	Intent to Bid	Do you intend to submit a bid?

Bid Messages

Bid Attachments

The following attachments are associated with this opportunity and will need to be retrieved separately

#	Filename	Description
Header	LEGAL NOTICE-2018-102.doc	Legal Notice
Header	General_Instructions_Bid.docx	General_Instructions_Bid
Header	Terms_of_Contract_Bid.docx	Terms_of_Contract_Bid
Header	3.0 Insurance_Requirements.doc	Insurance Requirements
Header	4.0 Special Conditions and Specifications.docx	Special Conditions and Specifications
Header	Attachment A.pdf	Attachment A-Tray Conveyor Drawings
Header	Attachment B.pdf	Attachment B-Existing Tray Conveyor Pictures
Header	HB23 CIQ.docx	Information Regarding Conflict of Interest Questionnaire
Header	CIQ_113015.pdf	Conflict of Interest Questionnaire
Header	HB89 Verification.docx	HB89/Chapter 2270 Verification
Header	W9_2014.pdf	W-9

Bid Attachments Requested

The following attachments are requested with this opportunity

#	Required	Specified Attachment
1	YES	Tray Conveyor Specification Sheet
2	NO	Specification Sheet(s) : Vendors bidding equivalent brand equipment for the fryer or kettle shall provide a specification sheet with their bid.
3	NO	Conflict of Interest Questionnaire
4	NO	W-9

Bid Attributes

Please review the following and respond where necessary

#	Name	Note	Response
1	Exceptions	Do you take exceptions to the specifications. If so, by separate attachment, please state your exceptions. Valid Responses: [Please Select], Yes, No	_____ (Required)
2	Insurance	I understand that the insurance requirements of this solicitation are required and a certificate of insurance shall be submitted to the Purchasing department if I am awarded all or a portion of the resulting contract. Please initial.	_____ (Required)
3	Subcontractors	State the business name of all subcontractors and the type of work they will be performing under this contract. If you are fully qualified to self-perform the entire contract, please respond with "Not Applicable-Self Perform".	_____ (Required)
4	Reference No. 1	List a company or governmental agency where these same/like products /services, as stated herein, have been	_____ (Required)

provided.

Include the following: Company/Entity, Contact, Address, City/State/Zip, Phone, and E-Mail.

- 5 Reference No. 2 List a company or governmental agency where these same/like products /services, as stated herein, have been provided. _____ (Required)
- Include the following: Company/Entity, Contact, Address, City/State/Zip, Phone, and E-Mail.
- 6 Reference No. 3 List a company or governmental agency where these same/like products /services, as stated herein, have been provided. _____ (Required)
- Include the following: Company/Entity, Contact, Address, City/State/Zip, Phone, and E-Mail.
- 7 Preferential Treatment The County of Collin, as a governmental agency of the State of Texas, may not award a contract to a nonresident bidder unless the nonresident's bid is lower than the lowest bid submitted by a responsible Texas resident bidder by the same amount that a Texas resident bidder would be required to underbid a nonresident bidder to obtain a comparable contract in the state in which the nonresident's principal place of business is located (Government Code, Title 10, V.T.C.A., Chapter 2252, Subchapter A). _____ (Required)
1. Is your principal place of business in the State of Texas?
2. If your principal place of business is not in Texas, in which State is your principal place of business?
3. If your principal place of business is not in Texas, does your state favor resident bidders (bidders in your state) by some dollar increment or percentage?
4. If your state favors resident bidders, state by what dollar amount or percentage.
- 8 Debarment Certification I certify that neither my company nor an owner or principal of my company has been debarred, suspended or otherwise made ineligible for participation in Federal Assistance programs under Executive Order 12549, "Debarment and Suspension," as described in the Federal Register and Rules and Regulations. _____ (Required)
- Please initial.
- 9 Immigration and Reform Act I declare and affirm that my company is in compliance with the Immigration and Reform Act of 1986 and all employees are legally eligible to work in the United States of America. _____ (Required)
- I further understand and acknowledge that any non-compliance with the Immigration and Reform Act of 1986 at any time during the term of this contract will render the contract voidable by Collin County.
- Please initial.
- 10 Disclosure of Certain Relationships Chapter 176 of the Texas Local Government Code requires that any vendor considering doing business with a local government entity disclose the vendor's affiliation or business relationship that might cause a conflict of interest with a local government entity. Subchapter 6 of the code _____ (Required)

requires a vendor to file a conflict of interest questionnaire (CIQ) if a conflict exists. By law this questionnaire must be filed with the records administrator of Collin County no later than the 7th business day after the date the vendor becomes aware of an event that requires the statement to be filed. A vendor commits an offense if the vendor knowingly violates the code. An offense under this section is a misdemeanor.

By submitting a response to this request, the vendor represents that it is in compliance with the requirements of Chapter 176 of the Texas Local Government Code.

Please send completed forms to the Collin County County Clerk's Office located at 2300 Bloomdale Rd., Suite 2104, McKinney, TX 75071.

Please initial.

11 Anti-Collusion Statement

Bidder certifies that its Bid/Proposal is made without prior understanding, agreement, or connection with any corporation, firm, or person submitting a Bid/Proposal for the same materials, services, supplies, or equipment and is in all respects fair and without collusion or fraud. _____ (Required)

No premiums, rebates or gratuities permitted; either with, prior to, or after any delivery of material or provision of services. Any such violation may result in Agreement cancellation, return of materials or discontinuation of services and the possible removal from bidders list.

Please initial.

12 Disclosure of Interested Parties

Section 2252.908 of the Texas Government Code requires a business entity entering into certain contracts with a governmental entity to file with the governmental entity a disclosure of interested parties at the time the business entity submits the signed contract to the governmental entity. Section 2252.908 requires the disclosure form (Form 1295) to be signed by the authorized agent of the contracting business entity, acknowledging that the disclosure is made under oath and under penalty of perjury. Section 2252.908 applies only to a contract that requires an action or vote by the governing body of the governmental entity before the contract may be signed or has a value of at least \$1 million. Section 2252.908 provides definitions of certain terms occurring in the section. _____ (Required)

Section 2252.908 applies only to a contract entered into on or after January 1, 2016.

Please initial.

13 Notification Survey

In order to better serve our offerors, the Collin County Purchasing Department is conducting the following survey. We appreciate your time and effort expended to submit your bid. Should you have any questions or require more information please call (972) 548-4165. _____ (Required)

How did you receive notice of this request?
Valid Responses: [Please Select], Plano Star Courier, Plan Room, Collin County eBid Notification, Collin County Website, Other

14 Bidder Acknowledgement

Bidder acknowledges, understands the specifications, any and all addenda, and agrees to the bid terms and conditions and can provide the minimum requirements _____ (Required)

stated herein. Bidder acknowledges they have read the document in its entirety, visited the site, performed investigations and verifications as deemed necessary, is familiar with local conditions under which work is to be performed and will be responsible for any and all errors in Bid submittal resulting from Bidder's failure to do so. Bidder acknowledges the prices submitted in this Bid have been carefully reviewed and are submitted as correct and final. If Bid is accepted, vendor further certifies and agrees to furnish any and all products upon which prices are extended at the price submitted, and upon conditions in the specifications of the Invitation for Bid.

Please initial.

Line Items

#	Qty	UOM	Description	Response
1	1	lot	Floor Fryer with Installation	\$ _____ Price

Item Notes: Refer to Section 4.14.1 for specifications.

Supplier Notes: _____

Item Attributes: Please review the following and respond where necessary

#	Name	Note	Response
1	Delivery and Installation	Delivery will be F.O.B. inside delivery at Collin County designated locations and all transportation charges are to be paid by the supplier to destination. Please state delivery and installation in calendar days from date of order.	_____ (Required)

Package Line Items:

#	Qty	UOM	Description	Response
1.1	1	each	Floor Fryer, Globe model GFF80G or Collin County approved equal.	\$ _____ (Required) Price

Supplier Notes: _____

1.2	1	lump sum	Floor Fryer Installation	\$ _____ (Required) Price
-----	---	----------	--------------------------	---------------------------------

Supplier Notes: _____

2	1	lot	Steam-Jacketed Floor Kettle with Installation	\$ _____ Price
---	---	-----	---	-------------------

Item Notes: Refer to Section 4.14.2 for specifications.

Supplier Notes: _____

Item Attributes: Please review the following and respond where necessary

#	Name	Note	Response
1	Delivery and Installation	Delivery will be F.O.B. inside delivery at Collin County designated locations and all transportation charges are to be paid by the supplier to destination. Please state delivery and installation in calendar days from date of order.	_____ (Required)

Package Line Items:

#	Qty	UOM	Description	Response
2.1	1	each	Steam-Jacketed Floor Kettle, Groen model AH-1E-80 or Collin County approved equal	\$ _____ (Required) Price

Supplier Notes: _____

2.2	1	lump sum	Floor Kettle Installation	\$ _____ (Required) Price
-----	---	----------	---------------------------	---------------------------------

Supplier Notes: _____

3	1	lot	Tray Make Up Conveyor with Installation	
Manufacturer: _____			Manufacturer #: _____	\$ _____
(Required)			(Required)	Price

Item Notes: Refer to Section 4.14.3 for specifications.

Bidder shall state Manufacturer and Model Number in the space provided and attach a specification sheet to their bid.

Supplier Notes: _____

Item Attributes: Please review the following and respond where necessary

#	Name	Note	Response
1	Delivery and Installation	Delivery will be F.O.B. inside delivery at Collin County designated locations and all transportation charges are to be paid by the supplier to destination. Please state delivery and installation in calendar days from date of order.	_____ (Required)

Package Line Items:

#	Qty	UOM	Description	Response
3.1	1	each	Tray Make Up Conveyor	\$ _____ (Required) Price

Item Notes: Vendor shall state Manufacturer and Model Number in the space provided and provide a specification sheet with their bid.

Supplier Notes: _____

3.2	1	lump sum	Tray Make Up Conveyor Installation	\$ _____ (Required) Price
-----	---	----------	------------------------------------	---------------------------------

Supplier Notes: _____

4 1 lump sum Alternate No. One-Equipment Trade-In: State Trade in Value for Existing Tray Conveyor

\$ _____
(Optional)
Price

Item Notes: Please enter a negative dollar amount of trade-in value for the existing conveyor. Existing conveyor shall be traded-in on an "as is-where is" basis. The County offers no warranty or guarantee on existing conveyor.

Supplier Notes: _____

1.0 GENERAL INSTRUCTIONS

1.0.1 Definitions

1.0.1.1 Bidder: refers to submitter.

1.0.1.2 Vendor/Contractor/Provider: refers to a Successful Bidder/Contractor/Service Provider.

1.0.1.3 Submittal: refers to those documents required to be submitted to Collin County, by a Bidder.

1.0.1.4 IFB: refers to Invitation For Bid.

1.1 If Bidder does not wish to submit an offer at this time, please submit a No Bid.

1.2 Awards shall be made not more than ninety (90) days after the time set for opening of submittals.

1.3 Collin County is always conscious and extremely appreciative of your time and effort in preparing your submittal.

1.4 Collin County exclusively uses ionWave Technologies, Inc. (Collin County eBid) for the notification and dissemination of all solicitations. The receipt of solicitations through any other company may result in your receipt of incomplete specifications and/or addendums which could ultimately render your bid non-compliant. Collin County accepts no responsibility for the receipt and/or notification of solicitations through any other company.

1.5 A bid may not be withdrawn or canceled by the bidder prior to the ninety-first (91st) day following public opening of submittals and only prior to award.

1.6 It is understood that Collin County, Texas reserves the right to accept or reject any and/or all Bids for any or all products and/or services covered in an Invitation For Bid (IFB), and to waive informalities or defects in submittals or to accept such submittals as it shall deem to be in the best interest of Collin County.

1.7 All IFB's submitted in hard copy paper form shall be submitted in a sealed envelope, plainly marked on the outside with the IFB number and name. A hard copy paper form submittal shall be manually signed in ink by a person having the authority to bind the firm in a contract. Submittals shall be mailed or hand delivered to the Collin County Purchasing Department.

1.8 No oral, telegraphic or telephonic submittals will be accepted. IFB's may be submitted in electronic format via Collin County eBid.

1.9 All Invitation For Bids (IFB) submitted electronically via Collin County eBid shall remain locked until official date and time of opening as stated in the Special Terms and Conditions of the IFB.

1.10 Time/date stamp clock in Collin County Purchasing Department shall be the official time of receipt for all Invitation for Bids (IFB) submitted in hard copy paper form. IFB's received in the Collin County Purchasing Department after submission deadline shall be considered void and unacceptable. Absolutely no late submittals will be considered. Collin County accepts no responsibility for technical difficulties related to electronic submittals.

1.11 For hard copy paper form submittals, any alterations made prior to opening date and time must be initialed by the signer of the IFB guaranteeing authenticity. Submittals cannot be altered or amended after submission deadline.

1.12 Collin County is by statute exempt from the State Sales Tax and Federal Excise Tax; therefore, the prices submitted shall not include taxes.

1.13 Any interpretations, corrections and/or changes to an Invitation For Bid, and related Specifications or extensions to the opening/receipt date will be made by addenda to the respective document by the Collin County Purchasing Department. Questions and/or clarification requests must be submitted no later than seven (7) days prior to the opening/receipt date. Those received at a later date may not be addressed prior to the public opening. Sole authority to authorize addenda shall be vested in Collin County Purchasing Agent as entrusted by the Collin County Commissioners' Court. Addenda may be transmitted electronically via Collin County eBid.

1.13.1 Addenda will be transmitted to all that are known to have received a copy of the IFB/RFQ/RFP/RFI/CSP and related Specifications. However, it shall be the sole responsibility of the Bidder/Quoter/Offeror to verify issuance/non-issuance of addenda and to check all avenues of document availability (i.e. **Collin County eBid** <https://collincountytexas.com>, telephoning Purchasing Department directly, etc.) prior to opening/receipt date and time to insure Bidder/Quoter/Offeror's receipt of any addenda issued. Bidder/Quoter/Offeror shall acknowledge receipt of all addenda.

1.14 All materials and services shall be subject to Collin County approval.

1.15 Collin County reserves the right to make award in whole or in part as it deems to be in the best interest of the County.

1.16 Any reference to model/make and/or manufacturer used in specifications is for descriptive purposes only. Products/materials of like quality will be considered.

1.17 Bidders taking exception to the specifications shall do so at their own risk. By offering substitutions, Bidder shall state these exceptions in the section provided in the IFB or by attachment. Exception/substitution, if accepted, must meet or exceed specifications stated therein. Collin County reserves the right to accept or reject any and/or all of the exception(s)/substitution(s) deemed to be in the best interest of the County.

1.19 Minimum Standards for Responsible Prospective Bidders: A prospective Bidder must meet the following minimum requirements:

1.19.1 have adequate financial resources, or the ability to obtain such resources as required;

1.19.2 be able to comply with the required or proposed delivery/completion schedule;

1.19.3 have a satisfactory record of performance;

1.19.4 have a satisfactory record of integrity and ethics;

1.19.5 be otherwise qualified and eligible to receive an award.

Collin County may request documentation and other information sufficient to determine Bidder's ability to meet these minimum standards listed above.

1.20 Vendor shall bear any/all costs associated with its preparation of an IFB.

1.21 Public Information Act: Collin County is governed by the Texas Public Information Act, Chapter 552 of the Texas Government Code. All information submitted by prospective bidders during the bidding process is subject to release under the Act.

1.22 The Bidder shall comply with Commissioners' Court Order No. 2004-167-03-11, County Logo Policy.

1.23 Interlocal Agreement: Successful bidder agrees to extend prices and terms to all entities that has entered into or will enter into joint purchasing interlocal cooperation agreements with Collin County.

1.24 Bid Openings: All bids submitted will be read at the county's regularly scheduled bid opening for the designated project. However, the reading of a bid at bid opening should be not construed as a comment on the responsiveness of such bid or as any indication that the county accepts such bid as responsive.

The county will make a determination as to the responsiveness of bids submitted based upon compliance with all applicable laws, Collin County Purchasing Guidelines, and project documents, including but not limited to the project specifications and contract documents. The county will notify the successful bidder upon award of the contract and, according to state law; all bids received will be available for inspection at that time.

1.25 Bidder shall comply with all local, state and federal employment and discrimination laws and shall not discriminate against any employee or applicant for employment because of race, color, religion, sex, age, national origin or any other class protected by law.

2.0 TERMS OF CONTRACT

2.1 A bid, when properly accepted by Collin County, shall constitute a contract equally binding between the Vendor/Contractor/Provider and Collin County. No different or additional terms will become part of this contract with the exception of a Change Order.

2.2 No oral statement of any person shall modify or otherwise change, or affect the terms, conditions or specifications stated in the resulting contract. All Amendments and/or Change Orders to the contract will be made in writing by Collin County Purchasing Agent.

2.3 No public official shall have interest in the contract, in accordance with Vernon's Texas Codes Annotated, Local Government Code Title 5, Subtitle C, Chapter 171.

2.4 The Vendor/Contractor/Provider shall comply with Commissioners' Court Order No. 96-680-10-28, Establishment of Guidelines & Restrictions Regarding the Acceptance of Gifts by County Officials & County Employees.

2.5 Design, strength, quality of materials and workmanship must conform to the highest standards of manufacturing and engineering practice.

2.6 Bids must comply with all federal, state, county and local laws concerning the type(s) of product(s)/service(s)/equipment/project(s) contracted for, and the fulfillment of all ADA (Americans with Disabilities Act) requirements.

2.7 All products must be new and unused, unless otherwise specified, in first-class condition and of current manufacture. Obsolete products, including products or any parts not compatible with existing hardware/software configurations will not be accepted.

2.8 Vendor/Contractor/Provider shall provide any and all notices as may be required under the Drug-Free Work Place Act of 1988, 28 CFR Part 67, Subpart F, to its employees and all sub-contractors to insure that Collin County maintains a drug-free work place.

2.9 Vendor/Contractor/Provider shall defend, indemnify and save harmless Collin County and all its officers, agents and employees and all entities, their officers, agents and employees who are participating in this contract from all suits, claims, actions, damages (including personal injury and or property damages), or demands of any character, name and description, (including attorneys' fees, expenses and other defense costs of any nature) brought for or on account of any injuries or damages received or sustained by any person, persons, or property on account of Vendor/Contractor/Provider's breach of the contract arising from an award, and/or any negligent act, error, omission or fault of the Vendor/Contractor/Provider, or of any agent, employee, subcontractor or supplier of Vendor/Contractor/Provider in the execution of, or performance under, any contract which may result from an award. Vendor/Contractor/Provider shall pay in full any judgment with costs, including attorneys' fees and expenses which are rendered against Collin County and/or participating entities arising out of such breach, act, error, omission and/or fault.

2.10 Expenses for Enforcement. In the event either Party hereto is required to employ an attorney to enforce the provisions of this Agreement or is required to commence legal proceedings to enforce the provisions hereof, the prevailing Party shall be entitled to recover from the other, reasonable attorney's fees and court costs incurred in connection with such enforcement, including collection.

2.11 If a contract, resulting from a Collin County IFB is for the execution of a public work, the following shall apply:

2.11.1 In accordance with V.T.C.A. 2253.021, a governmental agency that makes a public work contract with a prime contractor shall require the contractor, before beginning work, to execute to the governmental entity a Payment Bond if the contract is in excess of \$25,000.00. Such bond shall

be in the amount of the contract payable to the governmental entity and must be executed by a corporate surety in accordance with Section 1, Chapter 87, Acts of the 56th Legislature, Regular Session, 1959 (Article 7.19-1 Vernon's Texas Insurance Code).

2.11.2 In accordance with V.T.C.A. 2253.021, a governmental agency that makes a public work contract with a prime contractor shall require the contractor, before beginning work, to execute to the governmental entity a Performance Bond if the contract is in excess of \$100,000.00. Such bond shall be in the amount of the contract payable to the governmental entity and must be executed by a corporate surety in accordance with Section 1, Chapter 87, Acts of the 56th Legislature, Regular Session, 1959 (Article 7.19-1 Vernon's Texas Insurance Code).

2.12 Purchase Order(s) shall be generated by Collin County to the vendor. Collin County will not be responsible for any orders placed/delivered without a valid purchase order number.

2.13 The contract shall remain in effect until any of the following occurs: delivery of product(s) and/or completion and acceptance by Collin County of product(s) and/or service(s), contract expires or is terminated by either party with thirty (30) days written notice prior to cancellation and notice must state therein the reasons for such cancellation. Collin County reserves the right to terminate the contract immediately in the event the Vendor/Contractor/Provider fails to meet delivery or completion schedules, or otherwise perform in accordance with the specifications. Breach of contract or default authorizes the County to purchase elsewhere and charge the full increase in cost and handling to the defaulting Vendor/Contractor/Provider.

2.14 Collin County Purchasing Department shall serve as Contract Administrator or shall supervise agents designated by Collin County.

2.15 All delivery and freight charges (FOB Inside delivery at Collin County designated locations) are to be included as part of the bid price. All components required to render the item complete, installed and operational shall be included in the total bid price. Collin County will pay no additional freight/delivery/installation/setup fees.

2.16 Vendor/Contractor/Provider shall notify the Purchasing Department immediately if delivery/completion schedule cannot be met. If delay is foreseen, the Vendor/Contractor/Provider shall give written notice to the Purchasing Agent. The County has the right to extend delivery/completion time if reason appears valid.

2.17 The title and risk of loss of the product(s) shall not pass to Collin County until Collin County actually receives and takes possession of the product(s) at the point or points of delivery. Collin County shall generate a purchase order(s) to the Vendor/Contractor/Provider and the purchase order number must appear on all itemized invoices.

2.18 Invoices shall be mailed directly to the Collin County Auditor's Office, 2300 Bloomdale Road, Suite 3100, McKinney, Texas 75071. All invoices shall show:

2.18.1 Collin County Purchase Order Number;

2.18.2 Vendor's/Contractor's/Provider's Name, Address and Tax Identification Number;

2.18.3 Detailed breakdown of all charges for the product(s) and/or service(s) including applicable time frames.

2.19 Payment will be made in accordance with V.T.C.A., Government Code, Title 10, Subtitle F, Chapter 2251.

2.20 All warranties shall be stated as required in the Uniform Commercial Code.

2.21 The Vendor/Contractor/Provider and Collin County agree that both parties have all rights, duties, and remedies available as stated in the Uniform Commercial Code.

- 2.22 The Vendor/Contractor/Provider agree to protect Collin County from any claims involving infringements of patents and/or copyrights.
- 2.23 The contract will be governed by the laws of the State of Texas. Should any portion of the contract be in conflict with the laws of the State of Texas, the State laws shall invalidate only that portion. The remaining portion of the contract shall remain in effect. The contract is performable in Collin County, Texas.
- 2.24 The Vendor/Contractor/Provider shall not sell, assign, transfer or convey the contract, in whole or in part, without the prior written approval from Collin County.
- 2.25 The apparent silence of any part of the specification as to any detail or to the apparent omission from it of a detailed description concerning any point, shall be regarded as meaning that only the best commercial practices are to prevail. All interpretations of the specification shall be made on the basis of this statement.
- 2.26 Vendor/Contractor/Provider shall not fraudulently advertise, publish or otherwise make reference to the existence of a contract between Collin County and Vendor/Contractor/Provider for purposes of solicitation. As exception, Vendor/Contractor/Provider may refer to Collin County as an evaluating reference for purposes of establishing a contract with other entities.
- 2.27 The Vendor/Contractor/Provider understands, acknowledges and agrees that if the Vendor/Contractor/Provider subcontracts with a third party for services and/or material, the primary Vendor/Contractor/Provider (awardee) accepts responsibility for full and prompt payment to the third party. Any dispute between the primary Vendor/Contractor/Provider and the third party, including any payment dispute, will be promptly remedied by the primary vendor. Failure to promptly render a remedy or to make prompt payment to the third party (subcontractor) may result in the withholding of funds from the primary Vendor/Contractor/Provider by Collin County for any payments owed to the third party.
- 2.28 Vendor/Contractor/Provider shall provide Collin County with diagnostic access tools at no additional cost to Collin County, for all Electrical and Mechanical systems, components, etc., procured through this contract.
- 2.29 Criminal History Background Check: If required, ALL individuals may be subject to a criminal history background check performed by the Collin County Homeland Security prior to access being granted to Collin County. Upon request, Vendor/Contractor/Provider shall provide list of individuals to Collin County Purchasing Department within five (5) working days.
- 2.30 Non-Disclosure Agreement: Where applicable, vendor shall be required to sign a non-disclosure agreement acknowledging that all information to be furnished is in all respects confidential in nature, other than information which is in the public domain through other means and that any disclosure or use of same by vendor, except as provided in the contract/agreement, may cause serious harm or damage to Collin County. Therefore, Vendor agrees that Vendor will not use the information furnished for any purpose other than that stated in contract/agreement, and agrees that Vendor will not either directly or indirectly by agent, employee, or representative disclose this information, either in whole or in part, to any third party, except on a need to know basis for the purpose of evaluating any possible transaction. This agreement shall be binding upon Collin County and Vendor, and upon the directors, officers, employees and agents of each.
- 2.31 Vendors/Contractors/Providers must be in compliance with the Immigration and Reform Act of 1986 and all employees specific to this solicitation must be legally eligible to work in the United States of America.
- 2.32 Certification of Eligibility: This provision applies if the anticipated Contract exceeds \$100,000.00 and as it relates to the expenditure of federal grant funds. By submitting a bid or proposal in response to this solicitation, the Bidder certifies that at the time of submission, he/she is not on the Federal Government's list of suspended, ineligible, or debarred contractors. In the event of placement on the list between the time of bid/proposal submission and time of award, the Bidder will notify the Collin County Purchasing Agent. Failure to do so may result in terminating this contract for default.

2.33 Notice to Vendors/Contractors/Providers delivering goods or performing services within the Collin County Detention Facility: The Collin County Detention Facility houses persons who have been charged with and/or convicted of serious criminal offenses. When entering the Detention Facility, you could: (1) hear obscene or graphic language; (2) view partially clothed male inmates; (3) be subjected to verbal abuse or taunting; (4) risk physical altercations or physical contact, which could be minimal or possibly serious; (5) be exposed to communicable or infectious diseases; (6) be temporarily detained or prevented from immediately leaving the Detention Facility in the case of an emergency or “lockdown”; and (7) subjected to a search of your person or property. While the Collin County Sheriff’s Office takes every reasonable precaution to protect the safety of visitors to the Detention Facility, because of the inherently dangerous nature of a Detention Facility and the type of the persons incarcerated therein, please be advised of the possibility of such situations exist and you should carefully consider such risks when entering the Detention Facility. By entering the Collin County Detention Facility, you acknowledge that you are aware of such potential risks and willingly and knowingly choose to enter the Collin County Detention Facility.

2.34 Delays and Extensions of Time when applicable:

2.34.1 If the Vendor/Contractor/Provider is delayed at any time in the commence or progress of the Work by an act or neglect of the Owner or Architect/Engineer, or of an employee of either, or of a separate contractor employed by the Owner, or by changes ordered in the Work, or by labor disputes, fire, unusual delay in deliveries, unavoidable casualties or other causes beyond the Vendor/Contractor/Provider's control, or by delay authorized by the Owner pending mediation and arbitration, or by other causes which the Owner or Architect/Engineer determines may justify delay, then the Contract Time shall be extended by Change Order for such reasonable time as the Owner/Architect may determine.

2.34.2 If adverse weather conditions are the basis for a Claim for additional time, such Claim shall be documented by data substantiating that weather conditions were abnormal for the period of time and could not have been reasonably anticipated, and that the weather conditions had an adverse effect on the scheduled construction.

2.35 Disclosure of Certain Relationships: Chapter 176 of the Texas Local Government Code requires that any vendor considering doing business with a local government entity disclose the vendor’s affiliation or business relationship that might cause a conflict of interest with a local government entity. Subchapter 6 of the code requires a vendor to file a conflict of interest questionnaire (CIQ) if a conflict exists. By law this questionnaire must be filed with the records administrator of Collin County no later than the 7th business day after the date the vendor becomes aware of an event that requires the statement to be filed. A vendor commits an offense if the vendor knowingly violates the code. An offense under this section is a misdemeanor. By submitting a response to this request, the vendor represents that it is in compliance with the requirements of Chapter 176 of the Texas Local Government Code. Please send completed forms to the Collin County, County Clerk's Office located at 2300 Bloomdale Rd., Suite 2104, McKinney, TX 75071.

2.36 Disclosure of Interested Parties: Section 2252.908 of the Texas Government Code requires a business entity entering into certain contracts with a governmental entity to file with the governmental entity a disclosure of interested parties at the time the business entity submits the signed contract to the governmental entity. Section 2252.908 requires the disclosure form (Form 1295) to be signed by the authorized agent of the contracting business entity, acknowledging that the disclosure is made under oath and under penalty of perjury. Section 2252.908 applies only to a contract that requires an action or vote by the governing body of the governmental entity before the contract may be signed or has a value of at least \$1 million. Section 2252.908 provides definitions of certain terms occurring in the section. Section 2252.908 applies only to a contract entered into on or after January 1, 2016.

2.37 Vendors/Contractors/Providers must be in compliance with the provisions of Section 2270.001 of the Texas Government Code which states a governmental entity may not enter into a contract with a company for goods or services unless the contract contains a written verification from the company that it: (1) does not boycott Israel; and, (2) will not boycott Israel during the term of the contract. By submitting a response to a Collin County solicitation, the vendor will be required to sign the Chapter 2270 Verification form prior to a recommendation of the contract. This Act is effective September 1, 2017.

2.38 Vendors/Contractors/Providers must be in compliance with the provisions of Section 2252.152 and Section 2252.153 of the Texas Government Code which states, in part, contracts with companies engaged in business with Iran, Sudan, or Foreign Terrorist Organizations are prohibited. A governmental entity may not enter into a contract with a company that is listed on the Comptroller of the State of Texas website identified under Section 806.051, Section 807.051 or Section 2253.253 which do business with Iran, Sudan or any Foreign Terrorist Organization. This Act is effective September 1, 2017.

NOTE: All other terms and conditions (i.e. Insurance Requirements, Bond Requirements, etc.) shall be stated in the individual IFB Solicitation documents as Special Terms, Conditions and Specifications.

3.0 INSURANCE REQUIREMENTS

3.1 Before commencing work, the vendor shall be required, at its own expense, to furnish the Collin County Purchasing Agent with certified copies of all insurance certificate(s) indicating the coverage to remain in force throughout the term of this contract.

3.1.1 **Commercial General Liability** insurance including but not limited to the coverage indicated below. Coverage shall not exclude or limit Products/Completed Operations, Contractual Liability, or Cross Liability.

- Each Occurrence: \$1,000,000
- Personal & Adv Injury: \$1,000,000
- Products/Completed Operation: \$2,000,000
- General Aggregate: \$2,000,000

3.1.2 **Workers Compensation** insurance as required by the laws of Texas, and Employers' Liability.

Employers' Liability

- Liability, Each Accident: \$500,000
- Disease-Each Employee: \$500,000
- Disease – Policy Limit: \$500,000

3.1.3 **Commercial Automobile Liability** insurance including owned, non-owned, and hired vehicles used in connection with the contract.

- Combined Single Limit – Each Accident: \$1,000,000

3.1.4 **Umbrella/Excess Liability** insurance.

- Each Occurrence/Aggregate: \$1,000,000

3.2 With reference to the foregoing insurance requirement, the vendor shall endorse applicable insurance policies as follows:

3.2.1 A waiver of subrogation in favor of Collin County, its officials, employees, volunteers and officers shall be provided for General Liability, Commercial Automobile Liability and Workers' Compensation.

3.2.2 The vendor's insurance coverage shall name Collin County as additional insured under the General Liability policy.

3.2.3 All insurance policies shall be endorsed to require the insurer to immediately notify Collin County of any decrease in the insurance coverage limits.

3.2.4 All insurance policies shall be endorsed to the effect that Collin County will receive at least thirty (30) days notice prior to cancellation, non-renewal or termination of the policy.

3.2.5 All copies of Certificates of Insurance shall reference the project/contract number.

3.3 All insurance shall be purchased from an insurance company that meets the following requirements:

3.3.1 A financial rating of A+VII or better as assigned by the BEST Rating Company or equivalent.

3.4 Certificates of Insurance shall be prepared and executed by the insurance company or its authorized agent, and shall contain provisions representing and warranting the following:

3.4.1 Sets forth all endorsements and insurance coverages according to requirements and instructions contained herein.

3.4.2 Sets forth the notice of cancellation or termination to Collin County.

4.0 SPECIAL CONDITIONS AND SPECIFICATIONS

4.1 Authorization: By order of the Commissioners' Court of Collin County, Texas sealed bids will be received for IFB 2018-102, Kitchen Equipment for Collin County Jail.

4.2 Purpose: The intended purpose for this Invitation for Bid is to describe the requirements for the replacement of Kitchen Equipment for the Collin County Jail. Successful bidder(s) shall provide and install new equipment.

4.3 Pre-Bid: A pre bid meeting will be held on Monday, February 5, 2018 at 10:00 A.M at the Collin County Justice Center Jail Dock located at 4300 Community, McKinney, TX 75071. All prospective bidders are requested to have a representative present. It is the bidder's responsibility to review the site and documents to gain a full understanding of the requirements of the project.

4.4 Funding: Funds for payment for Collin County expenditures have been provided through the Collin County budget approved by the Commissioners' Court for this fiscal year only. All other participating entities expenditures have been provided through their entity's governing body for this fiscal year only. State of Texas statutes prohibit any obligation of public funds beyond the fiscal year for which a budget has been approved. Therefore, anticipated orders or other obligations that arise past the end of the current fiscal year shall be subject to budget approval.

4.5 Price Reduction: If during the life of the contract, the vendor's net prices to its customers for the same product(s) and/or services shall be reduced below the contracted price, it is understood and agreed that Collin County shall receive such price reduction.

4.6 Delivery/Installation Time: Bidder shall state the number of calendar days to complete delivery and installation of equipment at the County's designated location, after receipt of purchase order, on the Delivery and Installation Attribute for each line item.

4.7 Delivery/Setup/Installation: Location for delivery and installation is Collin County Jail, 4300 Community, McKinney, TX 75071. Delivery/freight/fuel surcharge, assembly, set-up and installation or any other fees shall be included in the bid price.

4.8 Testing: Testing may be performed at the request of Collin County, by an agent so designated by the County, without expense to Collin County.

4.9 Samples/Demos: When listed, samples/demos shall be furnished to the County at no expense.

4.10 Subcontractors: Bidder shall state names of all subcontractors and the type of work they will be performing on Attribute 3. If a bidder fails to specify a subcontractor, then he shall be deemed to have agreed that he is fully qualified to perform the contract himself, and that he will fully perform the contract himself.

No bidder whose bid is accepted shall (a) substitute any subcontractor, or (b) permit a subcontract to be voluntarily assigned or transferred or allow it to be performed by anyone other than the original subcontractor listed in the original proposal without approval in writing from the Collin County Purchasing Department.

The successful bidder further agrees that Collin County and its agents, servants and employees shall not be liable for any loss or damage resulting from personal injury, physical loss, harassment of or discrimination against employee or other violations of the provisions of this contract occasioned by the acts or omissions of the successful bidder's sub-contractors, their agents or employees. The indemnification provisions of this contract shall apply to all sub-contractors.

4.11 Warranties: Unless otherwise stated in these specifications, if within one year after final acceptance of the work by Collin County, any of the work or material is found to be defective or not in accordance with the specifications of the contract, the Vendor shall correct it promptly after receipt of a written notice from the County to do so. This obligation shall survive termination or completion of the contract. The County shall give such notice promptly after discovery of the condition.

If any materials or equipment utilized in this project is covered by a standard manufacturer's warranty greater than requirements specified herein, Vendor shall extend that coverage to Collin County.

4.12 Award: Award of contract shall be made to the responsive bidder(s) who submits the lowest and best bid meeting specifications. Collin County reserves the right to award by line item or in whole as deemed to be in the best interest of the County.

4.13 Approximate Usage: Approximate value of this contract is \$73,000.00. Approximate usage does not constitute an order, but only implies the probable quantity the County will use.

4.14 Requirements and Clarifications:

4.14.1 All equipment and components shall be new and unused.

4.14.2 Installation of new equipment shall include delivery, uncrating, set-in place, final hook-ups to existing utilities, start-up, and operator training.

4.14.3 Once awarded the contract, a mandatory background check performed by Collin County will be required for all persons who will work onsite.

4.14.4 Vendor shall haul all trash and packaging debris offsite. Vendor shall not use County dumpsters.

4.14.5 Brand names and model numbers provided in the following specifications are intended to be descriptive, not restrictive. Collin County will accept equivalent brand equipment. Vendors bidding equivalent brand equipment shall state the manufacturer and model numbers in the space provided on each line item and attach a specification sheet with their bid. If vendor fails to state the equivalent brand on

their bid, the County will assume vendor is bidding the brand and model indicated in these specifications and if awarded a contract, vendor shall furnish same.

4.15 Equipment Specifications:

4.15.1 Vendor shall provide and install one (1) Gas Floor Fryer, Globe model GFF80G or Collin County approved equal with the following specifications:

4.15.1.1 Fuel type: Natural gas

4.15.1.2 Oil capacity: eighty (80) pounds

4.15.1.3 Stainless steel fry tank

4.15.1.4 Two (2) wire mesh fry baskets

4.15.1.5 Cast iron burners

4.15.1.6 BTU's: approximately 150,000

4.15.1.7 Port drain with extension pipe

4.15.1.8 High limit thermostat with auto gas supply shut-off

4.15.1.9 Adjustable stainless steel legs and one (1) set of casters

4.15.1.10 Two (2) year warranty, parts and labor

4.15.1.11 Installation shall include connection to existing natural gas line

4.15.1.12 No de-installation of existing equipment will be required of the successful vendor. Existing equipment will be removed by County personnel.

4.15.1.13 Work hours for installation shall be Monday-Friday from 8:00 AM to 5:00 PM. Installation time shall be scheduled with the Sheriff's Office prior to beginning work.

4.15.2 Vendor shall provide and install one (1) Gas Steam-Jacketed Floor Kettle, Groen model AH-1E-80 or Collin County approved equal with the following specifications:

4.15.2.1 Fuel type: Natural gas

4.15.2.2 Capacity: 80 gallon

4.15.2.3 2/3 jacketed interior

4.15.2.4 Thermostatic control

4.15.2.5 Stainless steel welded construction

4.15.2.6 Installation shall include connection to existing gas line

4.15.2.7 No de-installation of existing equipment will be required of the successful vendor. Existing equipment will be removed by County personnel.

4.15.2.8 Work hours for installation shall be Monday-Friday from 8:00 AM to 5:00 PM. Installation time shall be scheduled with the Sheriff's Office prior to beginning work.

4.15.3 Vendor shall provide and install one (1) Tray Make-Up Conveyor with the following specifications:

4.15.3.1 Dual conveyor system allowing two lines of trays to move at once. Shall accommodate tray size: 13 ½" x 15".

4.15.3.2 Variable speed motor, approximately 0-40 feet per minute.

4.15.3.3 Photo-electric accumulation switch.

4.15.3.4 Remote start/stop stations (one for each conveyor) located at opposite end from motor.

4.15.3.5 Slide-out scrap basket at end of conveyor to prevent any scrap from falling on floor below.

4.15.3.6 Power Requirements:

4.15.3.6.1 Conveyor shall be powered by existing 220 volt outlet hardwired at floor.

4.15.3.6.2 Shall Include two (2) each, 110 volt outlets and two (2) each, 220 volt outlets installed on the side of the tray conveyor (one of each type outlet on each side of conveyor).

4.15.3.7 Conveyor frame shall be constructed from minimum 14 gauge stainless steel. Skirting around conveyor shall be minimum 16 gauge stainless steel.

4.15.3.8 Conveyor belt shall be constructed from heavy duty vinyl fabric material.

4.15.3.9 Refer to Attachment A-Drawings for conceptual design. All dimensions stated on drawing shall be considered approximations.

4.15.3.10 Refer to Attachment B-Pictures for view of work area and existing tray conveyor.

4.15.3.11 Tray Conveyor Installation:

4.15.3.11.1 Disconnect power supply from existing tray conveyor at localized 220 volt outlet in floor.

4.15.3.11.2 Remove existing tray conveyor and place on back dock at North end of Justice Center Jail.

4.15.3.11.3 Install new tray conveyor in same location.

4.15.3.11.4 Hardwire new tray conveyor to existing 220 volt power supply, making sure the connection is sealed to prevent moisture penetration.

4.15.3.11.5 Work hours for installation shall be Monday-Friday from 9:00 PM to 3:00 AM. Installation time shall be scheduled with the Sheriff's Office prior to beginning work.

4.15.4 Alternate No. One-Equipment Trade In:

4.15.4.1 The County is seeking to trade in the existing tray conveyor system being replaced on this project. Existing equipment shall be traded in on an "as is-where is" basis. The County offers no warranty or guarantee on the existing conveyor.

4.15.4.1.1 The motor has been removed from the existing tray conveyor and it is not currently in use. The manufacturer and model number of the conveyor is unknown.

4.15.4.2 Bidders choosing to offer a trade-in for the existing conveyor system shall state a trade-in value (negative dollar amount) on Bid Item 4.

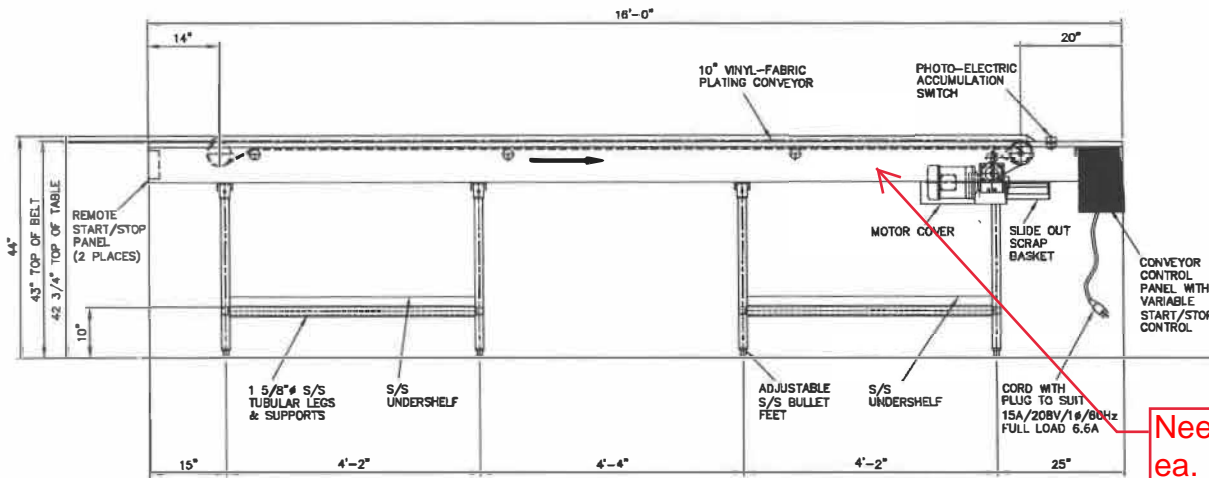

ELEVATION $\frac{A}{112}$

Needs to have 1 ea. 110v and 1 ea. 220v outlet on each side.

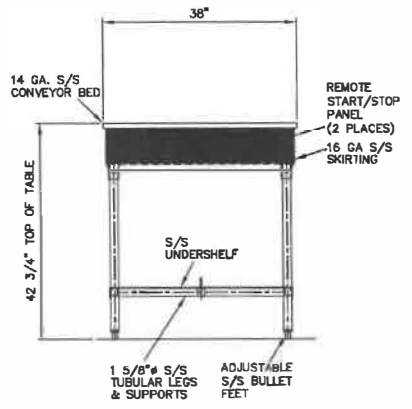

SECTION $\frac{B}{112}$

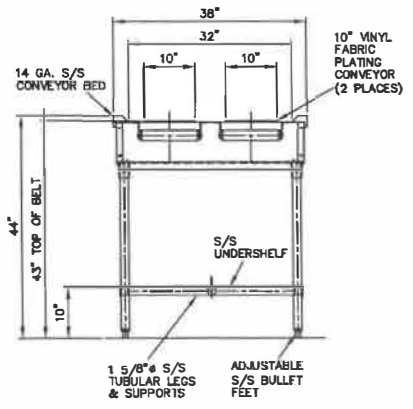

SECTION $\frac{C}{112}$

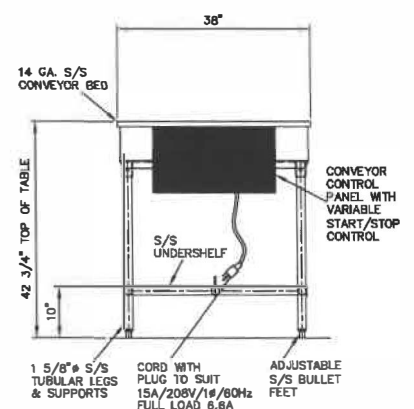

SECTION $\frac{D}{112}$

Attachment B

EXISTING



Standard's Name	Area	Code	Level	Comments
Handwashing	Handwashing	1001	1	
Food Safety	Food Safety	1002	1	
Sanitation	Sanitation	1003	1	



EXISTING



EXISTING



INFORMATION REGARDING CONFLICT OF INTEREST QUESTIONNAIRE

During the 79th Legislative Session, House Bill 914 was signed into law effective September 1, 2015, which added Chapter 176 to the Texas Local Government Code. Recent changes have been made to Chapter 176 pursuant to HB23, which passed the 84th Legislative Session. Chapter 176 mandates the public disclosure of certain information concerning persons doing business or seeking to do business with Collin County, including family, business, and financial relationships such persons may have with Collin County officers or employees involved in the planning, recommending, selecting and contracting of a vendor for this procurement.

For a copy of Form CIQ and CIS:

http://www.ethics.state.tx.us/filinginfo/conflict_forms.htm

The vendor acknowledges by doing business or seeking to do business with Collin County that he/she has been notified of the requirements under Chapter 176 of the Texas Local Government Code and that he/she is solely responsible for complying with the terms and conditions therein. Furthermore, any individual or business entity seeking to do business with Collin County who does not comply with this practice may risk award consideration of any County contract.

For a listing of current Collin County Officers:

<http://www.collincountytx.gov/government/Pages/officials.aspx>

The following County employees will be involved in the planning, recommending, selecting, and contracting for the attached procurement:

Department/Evaluation Team:

Bill Burke – Director of Building Projects
David Dooley – Building Projects Coordinator
James Skinner – Sheriff
Terry McCraw – Jail Administrator
Bryce Thompson – Jail Operations Captain

Purchasing:

Michalyn Rains – Purchasing Agent
Michelle Charnoski – Asst. Purchasing Agent
J. D. Griffin – Buyer II

Commissioners' Court:

Keith Self – County Judge
Susan Fletcher – Commissioner Precinct No. 1
Cheryl Williams – Commissioner Precinct No. 2
John Thomas – Commissioner Precinct No. 3
Duncan Webb – Commissioner Precinct No. 4

CONFLICT OF INTEREST QUESTIONNAIRE
For vendor doing business with local governmental entity

FORM CIQ

This questionnaire reflects changes made to the law by H.B. 23, 84th Leg., Regular Session.

This questionnaire is being filed in accordance with Chapter 176, Local Government Code, by a vendor who has a business relationship as defined by Section 176.001(1-a) with a local governmental entity and the vendor meets requirements under Section 176.006(a).

By law this questionnaire must be filed with the records administrator of the local governmental entity not later than the 7th business day after the date the vendor becomes aware of facts that require the statement to be filed. See Section 176.006(a-1), Local Government Code.

A vendor commits an offense if the vendor knowingly violates Section 176.006, Local Government Code. An offense under this section is a misdemeanor.

OFFICE USE ONLY

Date Received

1 Name of vendor who has a business relationship with local governmental entity.

2 **Check this box if you are filing an update to a previously filed questionnaire.** (The law requires that you file an updated completed questionnaire with the appropriate filing authority not later than the 7th business day after the date on which you became aware that the originally filed questionnaire was incomplete or inaccurate.)

3 Name of local government officer about whom the information is being disclosed.

Name of Officer

4 Describe each employment or other business relationship with the local government officer, or a family member of the officer, as described by Section 176.003(a)(2)(A). Also describe any family relationship with the local government officer. Complete subparts A and B for each employment or business relationship described. Attach additional pages to this Form CIQ as necessary.

A. Is the local government officer or a family member of the officer receiving or likely to receive taxable income, other than investment income, from the vendor?

Yes No

B. Is the vendor receiving or likely to receive taxable income, other than investment income, from or at the direction of the local government officer or a family member of the officer AND the taxable income is not received from the local governmental entity?

Yes No

5 Describe each employment or business relationship that the vendor named in Section 1 maintains with a corporation or other business entity with respect to which the local government officer serves as an officer or director, or holds an ownership interest of one percent or more.

6 Check this box if the vendor has given the local government officer or a family member of the officer one or more gifts as described in Section 176.003(a)(2)(B), excluding gifts described in Section 176.003(a-1).

7

Signature of vendor doing business with the governmental entity

Date

CONFLICT OF INTEREST QUESTIONNAIRE

For vendor doing business with local governmental entity

A complete copy of Chapter 176 of the Local Government Code may be found at <http://www.statutes.legis.state.tx.us/Docs/LG/htm/LG.176.htm>. For easy reference, below are some of the sections cited on this form.

Local Government Code § 176.001(1-a): "Business relationship" means a connection between two or more parties based on commercial activity of one of the parties. The term does not include a connection based on:

- (A) a transaction that is subject to rate or fee regulation by a federal, state, or local governmental entity or an agency of a federal, state, or local governmental entity;
- (B) a transaction conducted at a price and subject to terms available to the public; or
- (C) a purchase or lease of goods or services from a person that is chartered by a state or federal agency and that is subject to regular examination by, and reporting to, that agency.

Local Government Code § 176.003(a)(2)(A) and (B):

(a) A local government officer shall file a conflicts disclosure statement with respect to a vendor if:

(2) the vendor:

(A) has an employment or other business relationship with the local government officer or a family member of the officer that results in the officer or family member receiving taxable income, other than investment income, that exceeds \$2,500 during the 12-month period preceding the date that the officer becomes aware that

- (i) a contract between the local governmental entity and vendor has been executed;
- or
- (ii) the local governmental entity is considering entering into a contract with the vendor;

(B) has given to the local government officer or a family member of the officer one or more gifts that have an aggregate value of more than \$100 in the 12-month period preceding the date the officer becomes aware that:

- (i) a contract between the local governmental entity and vendor has been executed; or
- (ii) the local governmental entity is considering entering into a contract with the vendor.

Local Government Code § 176.006(a) and (a-1)

(a) A vendor shall file a completed conflict of interest questionnaire if the vendor has a business relationship with a local governmental entity and:

- (1) has an employment or other business relationship with a local government officer of that local governmental entity, or a family member of the officer, described by Section 176.003(a)(2)(A);
- (2) has given a local government officer of that local governmental entity, or a family member of the officer, one or more gifts with the aggregate value specified by Section 176.003(a)(2)(B), excluding any gift described by Section 176.003(a-1); or
- (3) has a family relationship with a local government officer of that local governmental entity.

(a-1) The completed conflict of interest questionnaire must be filed with the appropriate records administrator not later than the seventh business day after the later of:

(1) the date that the vendor:

- (A) begins discussions or negotiations to enter into a contract with the local governmental entity; or
- (B) submits to the local governmental entity an application, response to a request for proposals or bids, correspondence, or another writing related to a potential contract with the local governmental entity; or

(2) the date the vendor becomes aware:

- (A) of an employment or other business relationship with a local government officer, or a family member of the officer, described by Subsection (a);
- (B) that the vendor has given one or more gifts described by Subsection (a); or
- (C) of a family relationship with a local government officer.

CHAPTER 2270 VERIFICATION

I, _____, the undersigned representative of
(PRINT NAME)

(COMPANY)

do hereby verify that the company named-above, under the provisions of Subtitle F, Title 10, Government Code Chapter 2270:

- 1. Does not boycott Israel currently; and
- 2. Will not boycott Israel during the term of the contract.

Pursuant to Section 2270.001, Texas Government Code:

- 1. *“Boycott Israel” means refusing to deal with, terminating business activities with, or otherwise taking any action that is intended to penalize, inflict economic harm on, or limit commercial relations specifically with Israel, or with a person or entity doing business in Israel or in an Israeli-controlled territory, but does not include an action made for ordinary business purposes; and*
- 2. *“Company” means a for-profit sole proprietorship, organization, association, corporation, partnership, joint venture, limited partnership, limited liability partnership, or any limited liability company, including a wholly owned subsidiary, majority-owned subsidiary, parent company or affiliate of those entities or business associations that exist to make a profit.*

DATE

SIGNATURE OF COMPANY REPRESENTATIVE

TITLE

