



**COLLIN COUNTY**

**Construction, Collin County Justice Center,  
Upgrade Pneumatic to Electronic Actuators**

**IFB 2018-162**

**J. D. Griffin, CPPB  
Jack Hatchell Administration Building  
2300 Bloomdale Road, Ste. 3160  
McKinney, TX 75071**

**(P) 972-548-4116 (F) 972-548-4694  
jgriffin@collincountytx.gov**

Collin County exclusively uses IonWave Technologies, Inc. ([Collin County eBid](#)) for the notification and dissemination of all solicitations. The receipt of solicitations through any other means may result in your receipt of incomplete specifications and/or addendums which could ultimately render your bid/proposal non-compliant. Collin County accepts no responsibility for the receipt and/or notification of solicitations through any other means.

LEGAL NOTICE

By order of the Commissioners' Court of Collin County, Texas, sealed bids will be received by the Purchasing Agent, 2300 Bloomdale, Suite 3160, McKinney, TX 75071, until **2:00 P.M., Thursday, April 12, 2018**, for Invitation For Bid **Construction, Collin County Justice Center, Upgrade Pneumatic to Electronic Actuators (IFB No. 2018-162)**. A **Mandatory Pre-Bid** conference will be held **Tuesday, April 3, 2018 at 2:00 p.m.** at Collin County Justice Center Jail Lobby, 4300 Community Ave., McKinney, TX 75071. Bidders shall use lump sum pricing. All Bidders must submit, prior to the bid opening time, a Cashier's Check or acceptable Bid Bond payable without recourse to Collin County in the amount of not less than five percent (5%) of the total bid plus alternates as submitted. Contractor must furnish a performance, payment and maintenance bond within ten (10) consecutive calendar days following award of contract. Funds for payment have been provided through the Collin County budget approved by the Commissioner's Court for this fiscal year only. Bidders may obtain detailed specifications and other documents at Office of the Purchasing Agent: Collin County Administration Building, 2300 Bloomdale, Suite 3160, McKinney, TX 75071, 972-548-4165, or by going to: <https://collincountytx.ionwave.net>. Sealed bids will be opened on **Thursday, April 12, 2018 at 2:00 P.M.** by the Purchasing Agent, 2300 Bloomdale, Suite 3160, McKinney, TX 75071. The Commissioners' Court reserves the right to reject any and all bids.

.....

<b>ATTENTION:</b>	<b>CLASSIFIEDS</b>
<b>BILL TO:</b>	<b>ACCOUNT NO 06100315-000</b>
	<b>COMMISSIONER'S COURT</b>

NOTICE TO PUBLISHERS: Please publish in your issue on **Thursday, March 22, 2018** and **Thursday, March 29, 2018**. A copy of this notice and the publisher's affidavit must accompany the invoice when presented for payment.

<b>NEWSPAPER:</b>	<b><u>Plano Star Courier</u></b>
<b>DATE:</b>	<b><u>March 20, 2018</u></b>
<b>FAX:</b>	<b><u>972-529-1684</u></b>

**COLLIN COUNTY JUSTICE CENTER  
UPGRADE PNEUMATIC TO ELECTRONIC ACTUATORS**

**PROJECT MANUAL**

**FEBRUARY 23, 2018**



**ENGINEER:**

MD Engineering, LP, LLP  
500 North Central Expressway  
Suite 310  
Plano, TX 75074  
P: 469-467-0200  
F: 469-467-0300



**TABLE OF CONTENTS**

00 11 16      ADVERTISEMENT FOR BIDS

00 21 13      INSTRUCTION TO BIDDERS

00 41 00      BID FORM

00 43 13      BID BOND

00 45 47      CONFLICT OF INTEREST QUESTIONNAIRE

00 45 48      CHAPTER 2270

00 52 13      CONSTRUCTION AGREEMENT

00 54 25      W-9 FORM

00 61 11      PERFORMANCE BOND

00 61 13      PAYMENT BOND

00 61 19      MAINTENANCE BOND

23 00 10      MECHANICAL SUBMITTAL PROCESS

23 05 00      COMMON WORK RESULTS FOR HVAC

23 05 29      HANGERS AND SUPPORTS FOR HVAC PIPING AND EQUIPMENT

23 05 48      VIBRATION AND SEISMIC CONTROL FOR HVAC PIPING AND EQUIPMENT

23 05 53      IDENTIFICATION FOR HVAC PIPING AND EQUIPMENT

23 05 93      TESTING, ADJUSTING, AND BALANCING FOR HVAC

23 07 00      HVAC INSULATION

23 09 00      INSTRUMENTATION AND CONTROL FOR HVAC

23 31 50      HANGERS & SUPPORTS FOR DUCT WORK

26 00 10      ELECTRICAL SUBMITTAL PROCESS

26 05 00      COMMON WORK RESULTS FOR ELECTRICAL

26 05 01      ELECTRICAL DEMOLITION

26 05 02      ELECTRICALWORK IN EXISTING FACILITIES

26 05 03      FIRE STOPPING



26 05 19	LOW VOLTAGE ELECTRICAL POWER CONDUCTORS & CABLES
26 05 26	GROUNDING & BONDING FOR ELECTRICAL SYSTEMS
26 05 29	HANGERS & SUPPORTS FOR ELECTRICAL SYSTEMS
26 05 33.13	CONDUIT FOR ELECTRICAL SYSTEMS
26 05 33.16	BOXES FOR ELECTRICAL SYSTEMS
26 05 53	IDENTIFICATIONS FOR ELECTRICAL SYSTEMS
26 06 20	DISCONNECT SWITCHES

## SECTION 001116 - ADVERTISEMENT FOR BIDS

BY ORDER OF the Collin County Commissioners Court, Collin County, Texas, bids will be received electronically through Collin County eBid located at <https://collincountytx.ionwave.net>. Bidders are encouraged to submit bids electronically by utilizing Collin County eBid. However, you may submit a sealed hard copy paper bid to the Office of the Collin County Purchasing Agent. All bids, both electronic or hard copy paper form must be submitted as stated below:

**SUBMIT BIDS HARD COPY PAPER  
BIDS TO:**

**Office of the Purchasing Agent  
Collin County Administration Building  
2300 Bloomdale Road, Suite 3160  
McKinney, Texas 75071**

**\*\*NOTE:**

**All Correspondence must include suite  
number to assist in proper delivery.\*\***

**SUBMIT NO LATER THAN:**

**2:00 P.M., Thursday, April 12, 2018**

**MARK ENVELOPE:**

**IFB 2018-162**

**Project: Construction, Collin County Justice  
Center, Upgrade Pneumatic to Electronic  
Actuators**

***ALL BIDS MUST BE RECEIVED IN THE OFFICE OF THE PURCHASING AGENT  
BEFORE OPENING DATE AND TIME***

SCOPE OF WORK INCLUDES all materials, labor, equipment and services to produce or be incorporated in such construction. Contract will be a general contract for the replacement of pneumatic to DDC controls which consists of approximately 182 FSD damper motors and 134 automatic dampers for the temperature controls. See drawings for accurate location and count. This will be a turnkey bid. Payment for the contract work shall be made pursuant to the terms of the Contract Documents.

The opinion of probable construction cost for this contract is \$931,700.

Collin County uses Collin County eBid for the notification and dissemination of all solicitations for commodities and services. The receipt of solicitations through any other company may result in your receipt of incomplete specifications and/or addendums which could ultimately render your bid non-compliant. Collin County accepts no responsibility for the receipt and/or notification of solicitations through any other company.

COLLIN COUNTY APPRECIATES your time and effort in preparing a bid. Hard copy paper bid must be in a separate sealed envelope, manually signed in ink by a person having the authority to bind the firm in a contract and marked clearly on the outside as outlined above. Please note that all bids must be received at the designated location by the deadline shown. Bids received after deadline shall be considered void and unacceptable. Collin County is not responsible for lateness of mail, carrier, etc. and time/date stamp clock in the Collin County Purchasing Department shall be the official time of receipt. All bid forms provided in this Invitation for Bid must be completed prior

to submission. Failure to complete the forms shall render your bid null and void. We would appreciate you indicating on your "NO BID" response any requirements of this bid request which may have influenced your decision to "NO BID".

BIDS WILL BE publicly opened in the Office of the Purchasing Agent, 2300 Bloomdale Rd, Suite 3160, McKinney, TX 75071, at the date and time indicated above.

A MANDATORY PRE-BID CONFERENCE will be held by Collin County in the **Collin County Justice Center Jail Lobby** located at **4300 Community Ave, McKinney, TX 75071** on **Tuesday, April 3, 2018**, at **2:00 PM** in order for bidders to ask questions regarding the proposed work. All bidders desiring to bid the work should have a representative at the pre-bid conference; bidders that do not attend the pre-bid conference shall not be considered in the evaluation for award of a contract per Texas Local Government Code 262.0256. Attendance shall be mandatory at the pre-bid conference.

No oral, telegraphic, telephonic or facsimile bids will be considered. IFB's, RFP's, RFQ's and RFI's may be submitted in electronic format via Collin County eBid at <https://collincountytx.ionwave.net>

**BID SECURITY:** All Bidders must submit, prior to the bid opening time, a Cashier's Check or acceptable Bid Bond payable without recourse to Collin County in the amount of not less than five percent (5%) of the total bid plus alternates as submitted.

1. Bid Bond or Cashier's Check may be mailed or hand delivered to the Office of the Collin County Purchasing Agent, Collin County Administration Building, 2300 Bloomdale Road, Ste 3160, McKinney, TX 75071 and shall be delivered in an envelope, marked plainly on the outside with the Bid Name and Number.
2. Bidders submitting a bid via Collin County eBid shall upload a Bid Bond at <https://collincountytx.ionwave.net>

Regardless of delivery method, all Bid Bonds shall be received prior to the bid opening time to be considered.

The original Bid Bond shall be received in the Collin County Purchasing Department **no later than** close of business on the third working day after the bid opening. Late receipt of original Bid Bond shall be cause for rejection of bid.

**BONDS:** Contractor must furnish a performance bond, payment bond and one (1) year maintenance bond within ten (10) consecutive calendar days following award of contract. The bonds shall be issued by a corporate surety in accordance with all Texas Law, including but not limited to, Chapter 2253 of the Texas Government Code and Chapter 3503 of the Texas Insurance Code, for public works projects.

## SECTION 002113 - INSTRUCTIONS TO BIDDERS

### PART 1 - GENERAL REQUIREMENTS

#### 1.1 RELATED DOCUMENTS

- A. Drawings and general provisions of the Contract, including General and Supplementary Conditions and other Specification Sections, apply to this Section.

#### 1.2 DEFINITIONS

- A. All definitions set forth in the General Conditions of the Contract for Construction or in other Contract Documents are applicable to these Bidding Documents.
- B. Bidding Documents include the Advertisement or Invitation for Bids, Instructions to Bidders, the bid form, other sample bidding and contract forms and the proposed Contract Documents including any Addenda issued prior to receipt of bids.
- C. Addenda are written or graphic instruments issued prior to the opening of the Bidding Documents, which modify or interpret the Bidding Documents, including Drawings and Specifications, by additions, deletions, clarifications or corrections. Addenda will become part of the Contract Documents when the Construction Contract is executed.
- D. MD Engineering, L.P., L.L.P. will be hereafter referred to in the Project Manual as “Engineer” and all correspondence shall be addressed to: Michael Smith, P.E., MD Engineering, 500 N. Central Expy., Ste. 310, Plano, TX 75074.
- E. “Bill Burke” will be hereinafter referred to in this Project Manual as “Project Manager”.
- F. “Collin County” will be hereafter referred to in this Project Manual as “Owner”.
- G. A Bid is a complete and properly signed submittal to do the Work for designated portion thereof for the sums stipulated therein, submitted in accordance with the Bidding Documents.
- H. The Base Bid is the sum stated in the Bid for which the Bidder offers to perform the Work described in the Bidding Documents as the base, to which work may be added or from which work may be deleted for sums stated in Alternate Bids.
- I. An Alternate Bid (or Alternate) is an amount stated in the Bid to be added to or deducted from the amount of the Base Bid in the corresponding change in the Work, as described in the Bidding Documents or in the proposed Contract Documents.
- J. A Unit Price is an amount stated in the Bid as a price per unit of measurement for materials or service as described in the Bidding Documents or in the proposed Contract Documents.
- K. A Bidder is a person or entity who submits a Bid.
- L. A Sub-Bidder is a person or entity who submits a bid to a Bidder for materials or labor for a portion of the work.
- M. A Contractor is a person or entity who is determined to be the lowest responsible and responsive bidder to whom Owner (on the basis of Owner’s evaluation as hereinafter provided) makes an award.



- N. The Bid Requirements and Other General Conditions, as provided under the Division of the North Central Texas Council of Governments Standard Specifications for Public Works Construction will be applicable to this project, unless noted otherwise in the Contract Documents

### 1.3 EXAMINATION OF DOCUMENTS AND SITE

- A. Each bidder, by making his/her Bid, represents that he/she has read and understands the Bidding Documents.
- B. Each Bidder, by making his/her Bid, represents that he/she has visited the site, performed investigations and verifications as he/she deems necessary, and familiarized himself/herself with the local conditions under which the Work is to be performed and will be responsible for any and all errors in his/her bid resulting from his/her failure to do so.
- C. The location and elevations of the various utilities and pipe work included within the scope of the work are offered as a general guide only, without guarantee as to accuracy. The Contractor shall verify and investigate to his/her own satisfaction the location and elevation of all utilities, pipe work, and the like and shall adequately inform himself/herself of their relation to the work before submitting a bid.
- D. Before submitting a bid each bidder will, at bidder's own expense, make or obtain any additional examinations, investigations, explorations, tests and studies and obtain any additional information (surface, subsurface, and underground facilities) at or contiguous to the site, or otherwise which may affect cost, progress, performance or furnishing of the work and which bidder deems necessary to determine its bid for performing and furnishing the work in accordance with the time, price and other terms and conditions of the Contract Documents. Bidder will rely solely on its own site investigation and assumes the risk of any site conditions not discovered that may result in additional costs and all errors in the bid.
- E. On request in advance, Owner will provide each bidder access to the site to conduct explorations and tests as each bidder deems necessary for submission of a bid. Bidder shall fill all holes, clean up and restore the site to its former condition upon completion of such explorations.
- F. The lands upon which the work is to be performed, right-of way and easement for access thereto and other lands designated for use by Contractor in performing the work are identified in the Contract Documents.
- G. Each bidder by making his/her bid represents that his/her bid is based upon the materials, systems, and equipment required by the Bidding Documents without exception.

### 1.4 BIDDING DOCUMENTS

- A. Complete sets of Bidding Documents shall be used in preparing bids; neither County, nor Architect assume any responsibility for errors or misinterpretations resulting from use of incomplete sets of Bidding Documents.
- B. County or the Architect, in making copies of the Bidding Documents available on the above terms, do so only for the purpose of obtaining Bids on the Work and do not confer a license or grant for any other use.

### 1.5 BIDDING PROCEDURES

- A. All bids shall be prepared on the forms provided by the Architect and submitted in accordance with the Instruction to Bidders. The Architect or owner will furnish bidders

with bid forms which will provide for the following bid items. Bidders shall provide all requested information. Prices bid/proposed shall *only* be considered if they are provided in the appropriate space(s) on the Collin County bid form(s). For consideration, any additions or deductions to the bid/proposal prices offered must be shown under the exceptions section of the bid/proposal in the case of electronic submittal, ONLY in the case of a hard copy submittal will an additional attachment be allowed. Extraneous numbers, prices, comments, etc. or bidder/offeror generated documents appearing elsewhere on the bid or as an additional attachment shall be deemed to have no effect on the prices offered in the designated locations.

1. A single contract price for each bid item as detailed and described in these specifications.
  2. Acknowledgment of Addenda.
  3. Number of consecutive calendar days to complete project.
  4. Alternate bids.
  5. Unit prices.
- B. A bid (electronic or hard copy) is invalid if it has not been deposited at the designed location prior to the time and date for receipt of bids indicated in the Advertisement or Invitation For Bid, or prior to any extension thereof issued to the bidders. Bids received in County Purchasing Department after submission deadline shall be returned unopened and will be considered void and unacceptable. Owner is not responsible for lateness of mail, carrier, etc. and time/date stamp clock in County Purchasing Department shall be the official time of receipt.
- C. Unless otherwise provided in any supplement to these Instructions to Bidders, no bidder shall modify, withdraw or cancel his/her bid or any part thereof for ninety (90) consecutive calendar days after the time designated for the receipt of bids in the Advertisement or Invitation For Bid.
- D. Bids shall not contain any recapitulation of the Work to be done.
- E. The Bidder shall make no additional stipulations on the Bid Form nor limit or qualify his/her bid in any other manner. Bids so qualified will be subject to disqualification.
- F. Collin County is by statute exempt from the State Sales Tax and Federal Excise Tax; therefore, the prices submitted shall not include taxes.

## 1.6 DISCREPANCIES AND AMBIGUITIES

Any interpretations, corrections and/or changes to an Invitation For Bid and related Specifications or extensions to the opening/receipt date will be made by addenda to the respective document by the Collin County Purchasing Department. Questions and/or clarification requests must be submitted no later than seven (7) days prior to the opening/receipt date. Those received at a later date may not be addressed prior to the public opening. Sole authority to authorize addenda shall be vested in Collin County Purchasing Agent as entrusted by the Collin County Commissioners' Court. Addenda may be transmitted electronically via Collin County eBid, by facsimile, E-mail transmission or mailed via the US Postal Service.

- 1.6.1 Addenda will be transmitted to all that are known to have received a copy of the IFB and related Specifications. However, it shall be the sole responsibility of the Bidder to verify issuance/non-issuance of addenda and to check all avenues of document availability (i.e. Collin County eBid at <https://collincountytx.ionwave.net>; telephoning Purchasing Department directly, etc.) prior to opening/receipt date and time to insure Bidder's receipt of any addenda issued. Bidder shall acknowledge receipt of all addenda.

## 1.7 SUBSTITUTIONS

- A. Each bidder represents that his/her bid is based upon the materials and equipment described in the Bidding Documents.
- B. No substitution will be considered unless written request has been submitted to the Architect for approval at least seven (7) consecutive calendar days prior to the date for receipt of bids.
- C. If the Architect and Owner approves a proposed substitution, such approval will be set forth in an Addendum.

## 1.8 QUALIFICATION OF BIDDERS

- A. Within seven (7) consecutive calendar days following bid opening, the apparent low bidder shall submit with a properly executed Contractor's Qualification Statement as evidence to establish bidder's financial responsibility, experience and possession of such equipment as may be needed to prosecute the work in an expeditious, safe and satisfactory manner. This Statement shall include:
  - 1. List of current projects.
  - 2. List of projects completed within the past five years.
  - 3. Experience of key individuals of the organization.
  - 4. Trade and Bank references.
  - 5. A recent financial statement to confirm that the bidder has suitable financial status to meet obligations incidental to performing the work. Audited financial statements are not mandatory. Unaudited financial statements will be accepted. If bidder's firm does, however, have audited statements, please include a copy with your bid.
  - 6. A statement of cost for each major item of Work included in the Bid.
  - 7. A designation of the Work to be performed by the Bidder with his/her own forces.
  - 8. A list of names of the Subcontractors or other persons or organizations (including those who are to furnish materials or equipment fabricated to a special design) proposed for each portion of the Work. The Bidder will be required to establish to the satisfaction of the Architect and Owner the reliability and responsibility of the proposed Subcontractors. Prior to the award of the Contract, the Architect will notify the Bidder in writing if either the County or the Architect, after due investigation, has reasonable and substantial objection to any person or organization on such lists. If Owner or Architect has a reasonable and substantial objection to any person or organization on such list, and refuses in writing to accept such person or organization, the Bidder may, at his/her option, withdraw his/her Bid without forfeiture of Bid Security or provide an acceptable substitute. Subcontractors and other persons and organizations proposed by the Bidder and accepted by Owner and Architect must be used on the Work for which they were proposed and accepted, and shall not be changed except with the written approval of Owner and the Architect.
- B. Bidders may be disqualified and their bids not considered for any of the following specific reasons:
  - 1. Reason for believing collusion exists among bidders.
  - 2. The bidder being interested in any litigation against Owner.
  - 3. The bidder being in arrears on any existing contract or having defaulted on a previous contract.
  - 4. Lack of competency as revealed by the financial statement, experience and equipment, questionnaires, or qualification statement.
  - 5. Uncompleted work which in the judgment of Owner will prevent or hinder the prompt completion of additional work if awarded.

C. Minimum Standards For Responsible Prospective Bidders: A prospective Bidder must meet the following minimum requirements:

1. have adequate financial resources, or the ability to obtain such resources as required;
2. be able to comply with the required or proposed delivery/ completion schedule;
3. have a satisfactory record of performance;
4. have a satisfactory record of integrity and ethics; and
5. be otherwise qualified and eligible to receive an award.

Collin County may request representation and other information sufficient to determine Bidder's ability to meet these minimum standards listed above.

D. In determining to whom to award the contract, the Owner may consider;

1. the purchase price;
2. the reputation of the bidder/contractor/vendor and of the bidder/contractor/vendor's goods or services;
3. the quality of the bidder/contractor/vendor's goods or services;
4. the extent to which the goods or services meet the Owner's needs;
5. the bidder/contractor/vendor's past relationship with the Owner;
6. the total long-term cost to the Owner to acquire the bidder/contractor/vendor's goods or services; and
7. any other relevant factors specifically listed in the Instruction to Bidders..

## 1.9 PREPARATION OF BID

- A. Bidder shall submit his/her bid on the forms furnished by the Architect. All blank spaces in forms shall be correctly filled in and the bidder shall state the prices, written in words and in figures. Where there is discrepancy between the price written in words and the price written in figures, the price written in words shall govern. If bid is submitted by an individual, his/her name must be signed by him/her or his/her duly authorized agency. If the bid is submitted by a firm, association or partnership, the name and address of each member must be given, and the bid must be signed by an official or duly authorized agent. Powers of attorney authorizing agents or others to sign bids must be properly certified and must be in writing and submitted with the bid.
- B. Bidder shall bear any/all costs associated with it's preparation of any bid, proposal or submittal.
- C. Public Information Act: Collin County is governed by the Texas Public Information Act, Chapter 552 of the Texas Government Code. All information submitted by prospective bidders during the bidding process is subject to release under the Act.
- D. The Bidder shall comply with Commissioners' Court Order No. 2004-167-03-11, County Logo Policy.

## 1.10 BID SECURITY

- A. Each bid must be accompanied by Bid Security (in accordance with instructions set forth in section 00100-Advertisement For Bids) made payable to Owner in an amount of five percent (5%) of the bidder's maximum bid price and in the form of a Cashier's Check or a Bid Bond, duly executed by bidder as principal and having as surety thereon, a corporate surety authorized and admitted to do business in the State of Texas and licensed to issue such bond, as a guarantee that the bidder will enter into a Contract and execute required Performance, Payment, and one (1) year Maintenance Bonds within ten (10) consecutive calendar days of Collin County Commissioners' Court award of Contract.
- B. The Bid Security of the contractor will be retained until such bidder has executed the Contract Agreement and furnished the required Contract Security, whereupon, the Bid Security will be returned. If the contractor fails to execute and deliver the Agreement and furnish the required Contract Security within ten (10) consecutive calendar days of Collin County Commissioners' Court award of Contract, Owner may annul the award of contract and the Bid Security of that bidder will be forfeited. The Bid Security of the other bidders whom Owner believes to have a reasonable chance of receiving the award may be retained by Owner until the earlier of the seventh (7th) consecutive calendar day after the effective date of the Agreement or the ninety-fifth (95th) consecutive calendar day after the bid opening, whereupon, the Bid Security furnished by such bidders will be returned. Bid Security with bids which are not competitive will be returned within seven (7) consecutive calendar days after the contract award.
- C. Should the bidder to whom the Contract is awarded refuse or neglect to execute and file the contract and bonds within ten (10) consecutive calendar days of Collin County Commissioners' Court award of Contract, Owner may annul award of Contract and the Bid Security filed with the bid shall become the property of Owner, not as a penalty, but as liquidated damages. Owner reserves the right to award canceled Contract to next responsible, lowest and best bidder as it deems to be in the best interest of the County.
- D. Owner will have the right to retain the bid security of all bidders until either:
  - 1. the Contract has been executed and the bonds have been furnished, or
  - 2. the specified time has elapsed so that bids may be withdrawn, or
  - 3. all bids have been rejected.

## 1.11 PERFORMANCE BOND, LABOR & MATERIAL PAYMENT BOND, MAINTENANCE BOND

- A. The Contractor shall post with Owner, not later than ten (10) consecutive calendar days of Collin County Commissioners' Court award of Contract, a Performance Bond in the amount of one hundred percent (100%) of the total contract price in such form as is satisfactory to Owner, in compliance with Chapter 2253 of the Texas Government Code and all other applicable Texas Law, and on the form specified in the Contract Documents. This bond shall be executed by a corporate surety company duly authorized and admitted to do business in the State of Texas and licensed to issue such a bond in the State of Texas. The Contractor shall notify its corporate surety of any Contract changes.
- B. The Contractor shall post with Owner, not later than ten (10) consecutive calendar days of Collin County Commissioners' Court award of Contract, a Payment Bond in the amount of one hundred percent (100%) of the total contract price in such form as is satisfactory to Owner, in compliance with Chapter 2253 of the Texas Government Code and all other applicable Texas Law, and on the form specified in the Contract Documents. This bond shall be executed by a corporate surety company duly authorized and admitted to do

business in the State of Texas and licensed to issue such a bond in the State of Texas. The Contractor shall notify its corporate surety of any Contract changes.

- C. The Contractor shall post with Owner, not later than ten (10) consecutive calendar days of Collin County Commissioners' Court award of Contract, a one (1) year Maintenance Bond in the amount of ten percent (10%) of the total contract price in such form as is satisfactory to Owner, in compliance with Chapter 2253 of the Texas Government Code and all other applicable Texas Law, and on the form specified in the Contract Documents. This bond shall be executed by a corporate surety company duly authorized and admitted to do business in the State of Texas and licensed to issue such a bond in the State of Texas. The Contractor shall notify its corporate surety of any Contract changes.
- D. The Contractor must demonstrate to Owner that it can secure the required performance and payment bonds, issued by a corporate surety company authorized and admitted to do business in the State of Texas and licensed to issue such a bond in the State of Texas. Contractor must also demonstrate that the bond is not in excess of ten percent (10%) of the corporate surety company's capital and surplus. To the extent the amount of the bond exceeds ten percent (10%) of the corporate surety company's capital and surplus, such bond will not be accepted unless bidder provides written certification that the corporate surety company has reinsured the portion of the risk that exceeds ten percent (10%) of the corporate surety company's capital and surplus with one or more insurers who are duly authorized, accredited or trusted to do business in the State of Texas. The amount reinsured by any reinsurer must not exceed ten percent (10%) of the reinsurer's capital and surplus.
- E. The Contractor must file with the performance bond and payment bond, all documents and information necessary to establish that the agent signing the bond is authorized to write the bond in the amount requested, and if applicable, that reinsurance requirements, have been met, including limits and ratings or other evidence of company solvency.
- F. If the corporate surety company on any bond furnished by Contractor to Owner is declared bankrupt or becomes insolvent or such corporate surety company's right to do business in the State of Texas is revoked, the Contractor shall within five (5) consecutive calendar days thereafter substitute another bond and corporate surety company, both of which shall be acceptable to Owner.

#### 1.12 FILING BID

- A. All Bids, proposals, or submittals submitted in hard copy paper form shall be submitted in a sealed envelope, plainly marked on the outside with the Invitation for Bid (IFB) number and name. A hard copy paper form bid, proposal, or submittal shall be manually signed in ink by a person having the authority to bind the firm in a contract. Submittals, bids or proposals shall be mailed or hand delivered to the Collin County Purchasing Department.
- B. No oral, telegraphic or telephonic submittals will be accepted. Bids, proposals, or submittals may be submitted in electronic format via Collin County eBid at <https://collincountytexas.ionwave.net>.
- C. All Bids, submittals or proposals submitted electronically via Collin County eBid at <https://collincountytexas.ionwave.net> shall remain locked until official date and time of opening as stated in the Special Terms and Conditions of the IFB.
- D. For hard copy paper form bids, proposals, or submittals, any alterations made prior to opening date and time must be initialed by the signer of the bid, proposal, or submittal, guaranteeing authenticity. Bids, proposals, or submittals cannot be altered or amended after submission deadline.

- E. No bid, proposal, or submittal will be considered unless it is filed with the Owner Purchasing Department within the time limit for receiving bids as stated in the Advertisement for Bids or IFB. Each hard copy paper bid shall be in a sealed envelope plainly marked with the word "BID", and the name and bid number of the project as designated in the Advertisement for Bids or IFB.

#### 1.13 MODIFICATION AND WITHDRAWAL OF BID

- A. No bid, proposal, or submittal may be withdrawn or modified after the bid opening except where the award of the contract has been delayed beyond ninety (90) consecutive calendar days after date of bid opening or as per Texas Local Government Code, Title 8, Chapter 262, Subchapter C., Section 262.0305. Modifications after Award.

#### 1.14 IRREGULAR BID

- A. It is understood that Collin County, Texas reserves the right to accept or reject any and/or all Bids, proposals, or submittals for any or all products and/or services covered in an Invitation For Bid (IFB) and to waive informalities or defects in submittals or to accept such submittals as it shall deem to be in the best interest of Collin County.

#### 1.15 REJECTION OF BID

- A. The bidder acknowledges the right of Owner to reject any or all bids and to waive any informality or irregularity in any bid received. In addition, the bidder recognizes the right of Owner to reject a bid if the bidder failed to furnish any required Bid Security, or to submit the data required by the Bidding Documents, or if the bid is in any way incomplete or irregular.

#### 1.16 METHOD OF AWARD

- A. In evaluating bids, Owner will consider whether or not the bids comply with the prescribed requirements, base prices, any alternates, unit pricing, completion time, bidder's qualifications, bidder's proposed subcontractors, suppliers, etc., and other data as may be requested in the Bid Documents.
- B. Owner may conduct such investigations as Owner deems necessary to assist in the evaluation of any bid and to establish the responsibility, qualifications and financial ability of bidder, proposed subcontractors, suppliers and other persons and organizations to perform and furnish the Work in accordance with the Bidding Documents to Owner's satisfaction within the prescribed time.
- C. If the contract is to be awarded, it will be awarded to the lowest and best responsible bidder whose evaluation, by Owner, indicates to be in the best interests of the project. If no alternates are selected by Owner, the Owner may award the contract to a responsible bidder who submits the lowest and best bid.
- D. Evaluation of Alternates - Any and/or all or none of the alternates may be considered in evaluation. Owner may award Contract on base bid plus any and/or all or none of the alternates.
- E. Owner anticipates award within ninety (90) consecutive calendar days after bid opening.
- F. The bid, when properly accepted by the County, shall constitute a Contract equally binding between the contractor and Owner. No different or additional terms will become part of this Contract with the exception of a written Change Order, signed by both parties.

- G. No oral statement of any person shall modify or otherwise change, or affect the terms, conditions or specifications stated in the resulting contract. All change orders to the contract will be made in writing by Collin County Purchasing Agent.

#### 1.17 EXECUTION OF CONTRACT

- A. The person or persons, partnership, company, firm, association or corporation to whom a contract is awarded shall within ten (10) consecutive calendar days after such award, sign the necessary contract agreements and submit the required bonds entering into the required Contract with Owner. No contract shall be binding on Owner until it has been executed by Owner or his/her duly authorized representative, and delivered to the Contractor.

#### 1.18 FAILURE TO EXECUTE CONTRACT

- A. The failure of the Bidder to execute the required bonds or to sign the required Contract within ten (10) consecutive calendar days after the Contract is awarded, shall be considered by Owner as abandonment of his/her Bid, and Owner may annul the award, at the Owner's sole discretion.

#### 1.19 PURCHASE ORDER

- A. A purchase order(s) shall be generated by Owner to the contractor. The purchase order number **must** appear on all itemized invoices. Collin County will not be responsible for any orders placed or delivered without a valid purchase order number.

#### 1.20 NOTICE TO PROCEED

- A. Upon the execution and delivery of Bonds, Executed Contract by Contractor, progress schedule, proof of insurance, and all other documents required prior to commencing work herein, Owner will issue a written Notice to Proceed to the Contractor requesting that he/she proceed with construction, and the Contractor shall commence work within ten (10) consecutive calendar days after the date of Notice to Proceed.

#### 1.21 PAYMENT PROCEDURES

- A. Contractor shall submit Applications for Payment in accordance with the Contract, and payments shall be made in accordance with the Contract Documents.
- C. Final Payment: Upon final completion and acceptance of the work, Owner shall pay the remainder of the contract price as recommended by Architect, in accordance with Texas Government Code, Title 10, Subtitle F., Chapter 2251. Contractor(s) is required to pay subcontractors within ten (10) days after the contractor has received payment from the County.
- D. The Contractor understands, acknowledges and agrees that if the Contractor subcontracts with a third party for services and/or material, the primary Contractor (awardee) accepts responsibility for full and prompt payment to the third party. Any dispute between the primary Contractor and the third party, including any payment dispute, will be promptly remedied by the Contractor. Failure to promptly render a remedy or to make prompt payment to the third party (subcontractor) may result in the withholding of funds from the primary Contractor by Collin County for any payments owed to the third party.

#### 1.22 AFFIDAVIT OF BILLS PAID



- A. Prior to final acceptance of this project by Owner, the Contractor shall execute an affidavit that all bills for labor, materials, and incidentals incurred in the project construction have been paid in full, and that there are no claims pending.

1.23 EXEMPTION FROM STATE OF TEXAS AND LOCAL SALES TAX ON MATERIALS

- A. Owner qualifies for exemption from State and Local Sales Tax pursuant to the provisions of Chapter 151, Section 151.309 of the Texas Limited Sales, Excise and Use Tax Act. The Contractor performing this Contract may purchase all materials, supplies, equipment consumed in the performance of this Contract by issuing to his/her suppliers an exemption certificate in lieu of the tax. .

1.24 CONFLICT OF INTEREST

- A. No public official shall have interest, direct or indirect, in this contract, in accordance with Texas Local Government Code Title 5, Subtitle C, Chapter 171.

1.25 ETHICS

- A. The bidder/contractor shall comply with Commissioners Court Order No. 96-680-10-28, Establishment of Guidelines & Restrictions Regarding The Acceptance of Gifts by County Officials & County employees.

1.26 BID COMPLIANCE

- A. Bid must comply with all federal, state, county and local laws concerning this type of project and the fulfillment of all ADA (Americans With Disabilities Act) requirements.
- B. Design, strength, quality of materials and workmanship must conform to the highest standards of manufacturing and engineering practice.
- C. All products must be new and unused, unless otherwise specified, in first-class condition and of current manufacture.

1.27 DRUG FREE

- A. All bidders shall provide any and all notices as may be required under the Drug-Free Work Place Act of 1988, 41 U.S.C. 701, and Collin County Commissioners' Court Order No. 90-455-06-11, to its employees and all sub-contractors to insure that Owner maintains a drug-free work place. The use, possession or being under the influence of drugs and/or alcohol while working on this bid project or while on County property is prohibited and may result in removal of an individual from the project and/or immediate termination of contract. The County reserves the right to review drug testing records of any personnel involved in this bid project. The County may require, at contractor's expense, drug testing of contractor's personnel if no drug testing records exists or if such test results are older than six (6) months.
- B. Substances and cut-off levels are as follows:

<u>SUBSTANCE</u>	<u>MAXIMUM LEVEL</u>
Amphetamines	1000 NG/ML
Barbiturates	300 NG/ML
Benzodiazepines	300 NG/ML
Cocaine Metabolite	300 NG/ML
Opiates	300 NG/ML

Phencyclidine (PCP)	25 NG/ML
THC (Marijuana) Metabolite	100 NG/ML
Methadone, Urinary	300 NG/ML
Methaqualone, Urine	300 NG/ML
Propoxyphene	300 NG/ML

## 1.28 INDEMNIFICATION

A. To the fullest extent permitted by law, the CONTRACTOR and his sureties shall indemnify, defend and hold harmless the OWNER and all of its, past, present and future, officers, agents and employees from all suits, cause of action, claims, liabilities, losses, fines, penalties, liens, demands, obligations, actions, proceedings, of any kind, character, name and description brought or arising, on account of any injuries or damages received or sustained by any person, destruction or damage to any property on account of, in whole or part, the operations of the CONTRACTOR, his agents, employees or subcontractors; or on account of any negligent act or fault of the CONTRACTOR, his agents, employees or subcontractors in the execution of said Contract; failing to comply with any law, ordinance, regulation, rule or order of any governmental or regulatory body including those dealing with health, safety, welfare or the environment; on account of the failure of the CONTRACTOR to provide the necessary barricades, warning lights or signs; and shall be required to pay any judgment, with cost, which may be obtained against the OWNER growing out of such injury or damage. In no event shall OWNER be liable to CONTRACTOR for indirect or consequential damages or loss of income or profit irrespective of the cause, fault or reason for same. CONTRACTOR'S duty to indemnify herein shall not be limited by any limitation on the type or amount of damages payable by or for CONTRACTOR or any Subcontractor under workman's compensation acts, disability benefit acts or any other employee benefit acts.

In addition, the CONTRACTOR likewise covenants and agrees to, and does hereby, indemnify and hold harmless the OWNER from and against any and all injuries, loss or damages to property of the OWNER during the performance of any of the terms and conditions of this Contract, arising out of or in connection with or resulting from, in whole or in part, any and all alleged acts or omissions of officers, agents, servants, employees, contractors, subcontractors, licenses or invitees of the CONTRACTOR.

The rights and responsibilities provided in this indemnification provision shall survive the termination or completion of this Contract.

## 1.29 CONSTRUCTION SCHEDULE

- A. The time for completion is set forth herein and will be included in the Contract. All work shall be completed within the consecutive calendar day count shown in the Contractor's bid. The calendar day count shall commence ten (10) consecutive calendar days after the date of the Notice to Proceed.
- B. Prior to the issuance of the Notice to Proceed by Owner, the Contractor shall submit a detailed progress and schedule chart to Owner for review. This chart will be used to assure completion of the job within the number of consecutive calendar days stated in bid documents.

## 1.30 DELAYS AND EXTENSIONS OF TIME

- A. If the Contractor is delayed at any time in the commencement or progress of the Work by an act or neglect of the Owner or Architect, or of an employee of either, or of a separate contractor employed by the Owner, or by changes ordered in the Work, or by labor disputes,

fire, unusual delay in deliveries, unavoidable casualties or other causes beyond the Contractor's control, or by delay authorized by the Owner pending mediation and arbitration, or by other causes which the Architect determines may justify delay, then the Contract Time shall be extended by Change Order for such reasonable time as the Architect may determine.

- B. If adverse weather conditions are the basis for a Claim for additional time, such Claim shall be documented by data substantiating that weather conditions were abnormal for the period of time and could not have been reasonably anticipated, and that the weather conditions had an adverse effect on the scheduled construction.
- C. Contractor's sole remedy for any delays in the project, which are not the fault of the Contractor, shall be an equitable extension of time to perform the work, required by the Contract. In no event shall the Contractor be entitled to make a claim for delay, impact or acceleration damages against the Owner.

### 1.31 DAMAGES

A. Should the contractor fail to complete the project within the specified completion schedule the sum of \$550.00 per calendar day will be deducted from the moneys due the contractor for the work. This sum shall not be considered as a penalty, but rather as reasonable liquidated damages, since it would be impracticable or extremely difficult to fix the actual damages. An extension of time may be allowed for delays beyond the control of the contractor at the discretion of Owner.

### 1.32 TERMINATION

This contract shall remain in effect until any of the following occurs:

- A. completion of project;
- B. acceptance of work ordered; or
- C. termination by either party pursuant to the terms of the Contract with a thirty (30) days written notice prior to cancellation that must state therein the reasons for such cancellation.
- D. Breach of the contract by the Contractor for failure
  - 1. to meet completion schedules, or
  - 2. otherwise perform in accordance with these specifications.

Breach of contract or default authorizes the County to purchase elsewhere and charge the full increase in cost and handling to the defaulting Contractor.

### 1.33 PATENTS - COPYRIGHTS

A. The contractor agrees to protect Owner from any claims involving infringements of patents and/or copyrights. In no event shall Owner be liable to a contractor for any/all suits arising on the grounds of patent(s) or copyright(s) infringement.

### 1.34 VENUE; GOVERNING LAW

A. This contract will be governed by the laws of the State of Texas. Should any portion of this contract be in conflict with the laws of the State of Texas, the State laws shall invalidate only that portion. The remaining portion of the contract shall remain in effect. This contract is performable in Collin County, Texas.

1.35 ASSIGNMENT

- A. The contractor shall not sell, assign, transfer or convey this contract, in whole or in part, without the prior written approval from Collin County Commissioners' Court.

1.36 SILENCE OF SPECIFICATION

- A. The apparent silence of any part of the specification as to any detail or to the apparent omission from it of a detailed description concerning any point, shall be regarded as meaning that only the best commercial practices are to prevail. All interpretations of the specification shall be made on the basis of this statement.

1.37 PROVISION CONCERNING ESCALATOR CLAUSES

- A. Bid(s) containing any condition which provides for changes in the stated bid prices due to increase or decrease in the costs of materials, labor, or other items required for this project, will be rejected and returned to the bidder without being considered.

1.38 ESTIMATES OF QUANTITIES

- A. The quantities listed in the Bid Form will be considered as approximate and will be used for the comparison of bids. Payments will be made to the Contractor only for the actual quantities of work performed or materials furnished in accordance with the contract. The quantity of work to be done and the materials may be increased or decreased as provided for in the Contract Documents.

1.39 TREE PROTECTION OUTSIDE LIMITS OF WORK

- A. The Contractor will be required to obtain written authorization from Owner for the removal of any tree three inches (3") in diameter or greater for any area outside the limits of the street right-of-way or slope easement. It is the intent of Owner to preserve as much as possible the natural condition of the floodplains.

1.40 EXCAVATION/TRENCH SAFETY

A. TRENCH SAFETY

The CONTRACTOR shall be responsible for complying with state laws and federal regulations relating to trench safety, including those which may be enacted during the performance under this contract. The CONTRACTOR shall be responsible for selecting an appropriate method of providing trench safety after due consideration of the job conditions, location of utilities, pavement conditions and other relevant factors. Slope-back methods which may result in unnecessary displacement of utilities and/or destruction of pavement may not be used without permission from the OWNER. The CONTRACTOR shall be responsible for providing to the OWNER an acceptable trench safety plan signed and sealed by a Professional Architect qualified to do such work and registered in Texas. Devices used to provide trench safety such as trench shields and shoring systems will be likewise certified by professional Architects registered in the State of Texas or by a professional Engineer registered in the state of manufacture of the shield.

B. PAYMENT FOR TRENCH SAFETY

Payment for trench safety shall be by the lineal feet of trench exceeding a depth of five (5) ft. Excavation for slope-back methods shall be subsidiary to the trench safety pay item including replacement and recompaction. Excess excavation for other trench safety methods is also subsidiary to the trench safety pay item. Costs relating to the preparation of the trench safety plan including geotechnical investigation, testing and report preparation fees are all subsidiary to the pay item for trench safety. Should trench safety measures be required during contract performance where no pay item has been provided, then the CONTRACTOR shall immediately notify the OWNER and, if directed to do so, provide trench safety under the provisions of the contract. Should the OWNER fail to authorize the work, then the CONTRACTOR shall proceed under the provisions of the Contract. Trench safety requirements are mandatory and may not be waived.

#### C. PAYMENT FOR SPECIAL SHORING

Payment for special shoring, if any, shall be based on the square feet of shoring used.

- D. The Contractor must be made aware that on construction projects in which trench excavation will exceed a depth of five feet (5'), the uniform set of general conditions must require that the bid documents and the contract include detailed plans and specifications for adequate safety systems that meet Occupational Safety and Health Administration standards that will be in effect during the period of construction of the project. The Contractor shall provide a separate pay item for trench excavation safety in accordance with the Texas Health & Safety Code Chapter 756. The Contractor shall verify that these plans and specifications include a pay item for these same trench excavation safety systems, in accordance with Texas Government Code, Title 10, Section 2166.303, Uniform Trench Safety Conditions. The contractor shall insure that drainage from adjacent properties is not blocked by his/her excavations. Measurement and payment for excavation/trench safety systems will not be made directly, but considered subsidiary to the work.
- E. The Contractor shall be responsible for obtaining and paying for all surveys and testing, including geotechnical surveys and testing, necessary to insure it can comply with all laws regarding adequate trench excavation safety.

#### 1.41 CONSTRUCTION STAKING

- A. Architect will provide the Contractor with primary horizontal and vertical control to consist of one construction baseline and two benchmarks.
- B. The Contractor shall take all necessary precautions to preserve any and/or all markings and staking. Payment for costs of restaking shall be the responsibility of the Contractor.

#### 1.42 PERMITS

- A. Contractor shall be responsible for obtaining all necessary permits.

#### 1.43 MATERIALS TESTING

- A. Owner will be responsible for all materials testing.

#### 1.44 WAGE SCALE

- A. In accordance with Texas Government Code, Title 10, Section 2258, Prevailing Wage Rates, the general prevailing wage rate has been determined for this locality for the craft or type of workman needed to execute work of a similar character of the project listed herein. The

Contractor shall pay the prevailing wage rate in this locality to all his/her employees and subcontractors performing work on this project, and in no event shall the Contractor pay less than the rate shown in the following schedule.

General Decision Number: TX180289 01/12/2018 TX289

Superseded General Decision Number: TX20170289

State: Texas

Construction Type: Building

County: Collin County in Texas.

BUILDING CONSTRUCTION PROJECTS (does not include single family homes or apartments up to and including 4 stories).

Note: Under Executive Order (EO) 13658, an hourly minimum wage of \$10.35 for calendar year 2018 applies to all contracts subject to the Davis-Bacon Act for which the contract is awarded (and any solicitation was issued) on or after January 1, 2015. If this contract is covered by the EO, the contractor must pay all workers in any classification listed on this wage determination at least \$10.35 per hour (or the applicable wage rate listed on this wage determination, if it is higher) for all hours spent performing on the contract in calendar year 2018. The EO minimum wage rate will be adjusted annually. Please note that this EO applies to the above-mentioned types of contracts entered into by the federal government that are subject to the Davis-Bacon Act itself, but it does not apply to contracts subject only to the Davis-Bacon Related Acts, including those set forth at 29 CFR 5.1(a)(2)-(60). Additional information on contractor requirements and worker protections under the EO is available at [www.dol.gov/whd/govcontracts](http://www.dol.gov/whd/govcontracts).

Modification Number    Publication Date

0            01/05/2018

1            01/12/2018

ASBE0021-011 06/01/2016

Rates            Fringes

ASBESTOS WORKER/HEAT & FROST  
INSULATOR (Duct, Pipe and  
Mechanical System Insulation)...\$ 24.32            7.52

-----  
BOIL0074-003 01/01/2017

Rates            Fringes

BOILERMAKER.....\$ 28.00            22.35

-----  
CARP1421-002 04/01/2016

Rates            Fringes

MILLWRIGHT.....\$ 26.60 8.65

\* ELEV0021-006 01/01/2018

Rates Fringes

ELEVATOR MECHANIC.....\$ 39.97 32.645+a+b

FOOTNOTES:

A. 6% under 5 years based on regular hourly rate for all hours worked. 8% over 5 years based on regular hourly rate for all hours worked.

B. New Year's Day, Memorial Day, Independence Day, Labor Day, Thanksgiving Day, the Friday after Thanksgiving Day, Christmas Day, and Veterans Day.

-----  
ENGI0178-005 06/01/2014

Rates Fringes

POWER EQUIPMENT OPERATOR

(1) Tower Crane.....\$ 29.00 10.60

(2) Cranes with Pile

Driving or Caisson

Attachment and Hydraulic

Crane 60 tons and above.....\$ 28.75 10.60

(3) Hydraulic cranes 59

Tons and under.....\$ 27.50 10.60

-----  
IRON0263-005 06/01/2017

Rates Fringes

IRONWORKER (ORNAMENTAL AND  
STRUCTURAL).....\$ 23.25 7.32

-----  
PLUM0100-005 11/01/2017

Rates Fringes

HVAC MECHANIC (HVAC Unit  
Installation Only).....\$ 30.84 11.51

PIPEFITTER (Excludes HVAC  
Pipe Installation).....\$ 30.84 11.51

-----  
SUTX2014-015 07/21/2014

Rates Fringes

BRICKLAYER.....\$ 21.06 0.00

CARPENTER, Excludes Drywall Hanging, Form Work, and Metal Stud Installation.....	\$ 15.78	0.00	
CAULKER.....	\$ 15.16	0.00	
CEMENT MASON/CONCRETE FINISHER...	\$ 13.04		0.00
DRYWALL HANGER AND METAL STUD INSTALLER.....	\$ 13.00	0.00	
ELECTRICIAN (Alarm Installation Only).....	\$ 20.93	3.86	
ELECTRICIAN (Communication Technician Only).....	\$ 15.35	1.39	
ELECTRICIAN (Low Voltage Wiring Only).....	\$ 17.04	1.39	
ELECTRICIAN, Excludes Low Voltage Wiring and Installation of Alarms/Sound and Communication Systems.....	\$ 20.01	2.69	
FORM WORKER.....	\$ 11.89	0.00	
GLAZIER.....	\$ 16.46	3.94	
HIGHWAY/PARKING LOT STRIPING: Operator (Striping Machine).....	\$ 10.04	2.31	
INSTALLER - SIDING (METAL/ALUMINUM/VINYL).....	\$ 14.74		0.00
INSTALLER - SIGN.....	\$ 15.50	0.00	
INSULATOR - BATT.....	\$ 13.00	0.00	
IRONWORKER, REINFORCING.....	\$ 12.29		0.00
LABORER: Common or General.....	\$ 10.52		0.00
LABORER: Mason Tender - Brick...	\$ 10.54		0.00
LABORER: Mason Tender - Cement/Concrete.....	\$ 10.93	0.00	



LABORER: Pipelayer.....	\$ 13.00	0.35
LABORER: Plaster Tender.....	\$ 12.22	0.00
LABORER: Roof Tearoff.....	\$ 11.28	0.00
LABORER: Landscape and Irrigation.....	\$ 10.55	0.00
LATHER.....	\$ 16.00	0.00
OPERATOR: Backhoe/Excavator/Trackhoe.....	\$ 12.83	0.00
OPERATOR: Bobcat/Skid Steer/Skid Loader.....	\$ 13.93	0.00
OPERATOR: Bulldozer.....	\$ 18.29	1.31
OPERATOR: Drill.....	\$ 15.69	0.50
OPERATOR: Forklift.....	\$ 13.21	0.81
OPERATOR: Grader/Blade.....	\$ 13.03	0.00
OPERATOR: Loader.....	\$ 13.46	0.85
OPERATOR: Mechanic.....	\$ 17.52	3.33
OPERATOR: Paver (Asphalt, Aggregate, and Concrete).....	\$ 18.44	0.00
OPERATOR: Roller.....	\$ 15.04	0.00
PAINTER (Brush, Roller and Spray), Excludes Drywall Finishing/Taping.....	\$ 13.35	5.10
PAINTER: Drywall Finishing/Taping Only.....	\$ 14.24	3.83
PIPEFITTER (HVAC Pipe Installation Only).....	\$ 20.45	4.00
PLASTERER.....	\$ 16.58	0.00
PLUMBER, Excludes HVAC Pipe Installation.....	\$ 22.46	4.06

ROOFER.....	\$ 17.19	0.00
SHEET METAL WORKER (HVAC Duct Installation Only).....	\$ 21.13	4.79
SHEET METAL WORKER, Excludes HVAC Duct Installation.....	\$ 24.88	5.97
SPRINKLER FITTER (Fire Sprinklers).....	\$ 37.50	0.00
TILE FINISHER.....	\$ 11.22	0.00
TILE SETTER.....	\$ 14.25	0.00
TRUCK DRIVER: 1/Single Axle Truck.....	\$ 16.00	0.81
TRUCK DRIVER: Dump Truck.....	\$ 12.39	1.18
TRUCK DRIVER: Flatbed Truck.....	\$ 19.65	8.57
TRUCK DRIVER: Semi-Trailer Truck.....	\$ 12.50	0.00
TRUCK DRIVER: Water Truck.....	\$ 12.00	4.11

-----

WELDERS - Receive rate prescribed for craft performing operation to which welding is incidental.

=====

Note: Executive Order (EO) 13706, Establishing Paid Sick Leave for Federal Contractors applies to all contracts subject to the Davis-Bacon Act for which the contract is awarded (and any solicitation was issued) on or after January 1, 2017. If this contract is covered by the EO, the contractor must provide employees with 1 hour of paid sick leave for every 30 hours they work, up to 56 hours of paid sick leave each year. Employees must be permitted to use paid sick leave for their own illness, injury or other health-related needs, including preventive care; to assist a family member (or person who is like family to the employee) who is ill, injured, or has other health-related needs, including preventive care; or for reasons resulting from, or to assist a family member (or person who is like family to the employee) who is a victim of, domestic violence, sexual assault, or stalking. Additional information on contractor requirements and worker protections under the EO is available at [www.dol.gov/whd/govcontracts](http://www.dol.gov/whd/govcontracts).

Unlisted classifications needed for work not included within the scope of the classifications listed may be added after award only as provided in the labor standards contract clauses (29CFR 5.5 (a) (1) (ii)).

-----

The body of each wage determination lists the classification and wage rates that have been found to be prevailing for the cited type(s) of construction in the area covered by the wage determination. The classifications are listed in alphabetical order of "identifiers" that indicate whether the particular rate is a union rate (current union negotiated rate for local), a survey rate (weighted average rate) or a union average rate (weighted union average rate).

#### Union Rate Identifiers

A four letter classification abbreviation identifier enclosed in dotted lines beginning with characters other than "SU" or "UAVG" denotes that the union classification and rate were prevailing for that classification in the survey. Example: PLUM0198-005 07/01/2014. PLUM is an abbreviation identifier of the union which prevailed in the survey for this classification, which in this example would be Plumbers. 0198 indicates the local union number or district council number where applicable, i.e., Plumbers Local 0198. The next number, 005 in the example, is an internal number used in processing the wage determination. 07/01/2014 is the effective date of the most current negotiated rate, which in this example is July 1, 2014.

Union prevailing wage rates are updated to reflect all rate changes in the collective bargaining agreement (CBA) governing this classification and rate.

#### Survey Rate Identifiers

Classifications listed under the "SU" identifier indicate that no one rate prevailed for this classification in the survey and the published rate is derived by computing a weighted average rate based on all the rates reported in the survey for that classification. As this weighted average rate includes all rates reported in the survey, it may include both union and non-union rates. Example: SULA2012-007 5/13/2014. SU indicates the rates are survey rates based on a weighted average calculation of rates and are not majority rates. LA indicates the State of Louisiana. 2012 is the year of survey on which these classifications and rates are based. The next number, 007 in the example, is an internal number used in producing the wage determination. 5/13/2014 indicates the survey completion date for the classifications and rates under that identifier.

Survey wage rates are not updated and remain in effect until a new survey is conducted.

#### Union Average Rate Identifiers

Classification(s) listed under the UAVG identifier indicate that no single majority rate prevailed for those classifications; however, 100% of the data reported for the classifications was union data. EXAMPLE: UAVG-OH-0010 08/29/2014. UAVG indicates that the rate is a weighted union average rate. OH indicates the state. The next number, 0010 in the example, is an internal number used in producing the wage determination. 08/29/2014 indicates the survey completion date for the classifications and rates under that identifier.

A UAVG rate will be updated once a year, usually in January of each year, to reflect a weighted average of the current negotiated/CBA rate of the union locals from which the rate is based.

-----

1.) Has there been an initial decision in the matter? This can be:

- \* an existing published wage determination
- \* a survey underlying a wage determination
- \* a Wage and Hour Division letter setting forth a position on a wage determination matter
- \* a conformance (additional classification and rate) ruling

On survey related matters, initial contact, including requests for summaries of surveys, should be with the Wage and Hour Regional Office for the area in which the survey was conducted because those Regional Offices have responsibility for the Davis-Bacon survey program. If the response from this initial contact is not satisfactory, then the process described in 2.) and 3.) should be followed.

With regard to any other matter not yet ripe for the formal process described here, initial contact should be with the Branch of Construction Wage Determinations. Write to:

Branch of Construction Wage Determinations  
Wage and Hour Division  
U.S. Department of Labor  
200 Constitution Avenue, N.W.  
Washington, DC 20210

2.) If the answer to the question in 1.) is yes, then an interested party (those affected by the action) can request review and reconsideration from the Wage and Hour Administrator (See 29 CFR Part 1.8 and 29 CFR Part 7). Write to:

Wage and Hour Administrator  
U.S. Department of Labor  
200 Constitution Avenue, N.W.  
Washington, DC 20210

The request should be accompanied by a full statement of the interested party's position and by any information (wage payment data, project description, area practice material, etc.) that the requestor considers relevant to the issue.

3.) If the decision of the Administrator is not favorable, an interested party may appeal directly to the Administrative Review Board (formerly the Wage Appeals Board). Write to:

Administrative Review Board  
U.S. Department of Labor  
200 Constitution Avenue, N.W.  
Washington, DC 20210

4.) All decisions by the Administrative Review Board are final.

=====

END OF GENERAL DECISION

- B. Except for work on legal holidays, the “Ge
- B. Except for work on legal holidays, the “General Prevailing Rate of Per Diem Wage” for the various crafts or type of workers or mechanics is the product of (a) the number of hours worked per day, except for overtime hours, times (b) the above respective rate per hour.
  - C. For legal holidays, the “General Prevailing Rate of Per Diem Wage” for the various crafts or type of workers or mechanics is the product of (a) one and one-half times the above respective rate per hour, times (b) the number of hours worked on the legal holiday.
  - D. For overtime work, the “General Prevailing Rate of Per Diem Wage” for the various crafts or type of workers or mechanics is the product of (a) one and one-half times the above respective rate per hour, times (b) the number of hours worked on overtime.
  - E. Under the provisions of Texas Government Code, Title 10, Section 2258, Prevailing Wage Rates, the contractor or subcontractor of the contractor shall forfeit as a penalty to the entity on whose behalf the contract is made or awarded, sixty dollars (\$60.00) for each calendar day, or portion thereof, that the worker is paid less than the wage rates stipulated in the contract.
  - F. If the construction project involves the expenditure of Federal funds in excess of \$2,000, the minimum wages to be paid various classes of laborers and mechanics will be based upon the wages that will be determined by the Secretary of Labor to be prevailing for the corresponding classes of laborers and mechanics employed on the project of a character similar to the contract work.

- 1.45 Collin County Purchasing Department shall serve as Contract Administrator or shall supervise agents designated by Collin County.
- 1.46 All warranties shall be stated as required in the Uniform Commercial Code.
- 1.47 The Contractor and Collin County agree that both parties have all rights, duties, and remedies available as stated in the Uniform Commercial Code.
- 1.48 Contractor shall not fraudulently advertise, publish or otherwise make reference to the existence of a contract between Collin County and Contractor for purposes of solicitation. As exception, Contractor may refer to Collin County as an evaluating reference for purposes of establishing a contract with other entities.
- 1.49 Contractor shall provide Collin County with diagnostic access tools at no additional cost to Collin County, for all Electrical and Mechanical systems, components, etc., procured through this contract.
- 1.50 **CRIMINAL HISTORY BACKGROUND CHECK:** If required, ALL individuals may be subject to a criminal history background check performed by the Collin County's Sheriff's Office prior to access being granted to Collin County property or facilities. Upon request, Contractor shall provide list of individuals to Collin County Purchasing Department within five (5) working days.
- 1.51 Vendors/Contractors/Providers must be in compliance with the Immigration and Reform Act of 1986 and all employees specific to this solicitation must be legally eligible to work in the United States of America.

- 1.52 **CERTIFICATION OF ELIGIBILITY:** This provision applies if the anticipated Contract exceeds \$100,000.00 and as it relates to the expenditure of federal grant funds. By submitting a bid or proposal in response to this solicitation, the Bidder/Quoter/Offeror certifies that at the time of submission, he/she is not on the Federal Government's list of suspended, ineligible, or debarred contractors. In the event of placement on the list between the time of bid/proposal submission and time of award, the Bidder/Quoter/Offeror will notify the Collin County Purchasing Agent. Failure to do so may result in terminating this contract for default.
- 1.53 **NOTICE TO CONTRACTORS:** The Collin County Detention Facility houses persons who have been charged with and/or convicted of serious criminal offenses. When entering the Detention Facility, you could: (1) hear obscene or graphic language; (2) view partially clothed male inmates; (3) be subjected to verbal abuse or taunting; (4) risk physical altercations or physical contact, which could be minimal or possibly serious; (5) be exposed to communicable or infectious diseases; (6) be temporarily detained or prevented from immediately leaving the Detention Facility in the case of an emergency or "lockdown; and (7) subjected to a search of your person or property. While the Collin County Sheriff's Office takes every reasonable precaution to protect the safety of visitors to the Detention Facility, because of the inherently dangerous nature of a Detention Facility and the type of the persons incarcerated therein, please be advised that the possibility of such situations exist and you should carefully consider such risks when entering the Detention Facility. By entering the Collin County Detention Facility, you acknowledge that you are aware of such potential risks and willingly and knowingly choose to enter the Collin County Detention Facility.
- 1.54 Contractors doing business with OWNER agree to comply with Federal Executive Order 13465 E-Verify. It is OWNER's intention and duty to comply and support the Immigration and Nationality Act (INA) which includes provisions addressing employment eligibility, employment verification and non-discrimination. According to the INA, contractors/employers may hire only persons who may legally work in the United States. Subsequently, contractors and subcontractors doing business with OWNER must confirm their enrollment in the E-Verify system which verifies employment eligibility through completion and checking of I-9 forms. OWNER reserves the right to audit contractors process to verify enrollment compliance.
- 1.55 **INSURANCE REQUIREMENTS**
- A. **CONTRACTOR'S INSURANCE**
1. Before commencing work, the CONTRACTOR and each subcontractor shall be required, at its own expense, to furnish the Collin County Purchasing Agent with certified copies of all insurance certificate(s) required by Texas Law, and the coverages required herein, indicating the coverage is to remain in force throughout the term of this Contract. Without limiting any of the other obligations or liabilities of the CONTRACTOR, during the term of the Contract the CONTRACTOR and each subcontractor at their own expense shall purchase and maintain the herein stipulated minimum insurance with companies duly approved to do business in the State of Texas and satisfactory to the OWNER. Certificates of each policy shall be delivered to the OWNER before any work is started, along with a written statement from the issuing company stating that said policy shall not be canceled, nonrenewed or materially changed without 30 days advance written notice being given to the OWNER.
  2. In addition to any coverage required by Texas Law, the CONTRACTOR shall provide the following coverages at not less than the specified amounts:
- B. Workers Compensation insurance required by Texas Law at statutory limits, including employer's liability coverage of not less than \$1,000,000. In addition to

these, the CONTRACTOR must comply with all the requirements of the Texas Department of Insurance, Division of Workers' Compensation; (Note: If you have questions concerning these requirements, you are instructed to contact the DWC.)

1. By signing this contract or providing or causing to be provided a certificate of coverage, the CONTRACTOR is representing to the OWNER that all employees of the CONTRACTOR and its subcontractors who will provide services on the Project will be covered by workers compensation coverage for the duration of the Project, that the coverage will be based on proper reporting of classification codes and payroll amounts, and that all coverage agreements will be filed with the appropriate insurance carrier or, in the case of a self-insured, with the commission's Division of Self-Insurance Regulation. Providing false or misleading information may subject the CONTRACTOR to administrative penalties, criminal penalties, civil penalties, or other civil actions.

2. The CONTRACTOR'S failure to comply with any of these provisions is a breach of Contract by the Contractor which entitles the OWNER to declare the Contract void if the CONTRACTOR does not remedy the breach within ten (10) days after receipt of notice of breach from the OWNER.

- C. Broad form commercial general liability insurance, including independent contractor's liability, completed operations and contractual liability, written on an occurrence form, covering, but not limited to, the liability assumed under the indemnification provisions of this contract, fully insuring CONTRACTOR'S (or subcontractor's) liability for injury to or death of OWNER'S employees and third parties, extended to include personal injury liability coverage with damage to property, with minimum limits as set forth below:

General Aggregate \$2,000,000

Products — Components/Operations Aggregate \$2,000,000

Personal and Advertising Injury \$ 1,000,000

Each Occurrence \$ 2,000,000

1. The policy shall include coverage extended to apply to completed operations, asbestos hazards (if this project involves work with asbestos) and XCU (explosion, collapse and underground) hazards. The completed operations coverage must be maintained for a minimum of one year after final completion and acceptance of the work, with evidence of same filed with OWNER.

- C. D. Comprehensive automobile and truck liability insurance, covering owned, hired and non-owned vehicles, with a combined bodily injury and property damage minimum limit of \$1,000,000 per occurrence; or separate limits of \$1,000,000 for bodily injury (per person), \$1,000,000 for bodily injury (per accident) and \$1,000,000 for property damage. Such insurance shall include coverage for loading and unloading hazards.

- E. OWNER'S PROTECTIVE LIABILITY INSURANCE  
CONTRACTOR shall obtain, pay for and maintain at all times during the prosecution of the work under this contract an OWNER'S protective liability insurance policy naming the OWNER as insured for property damage and bodily

injury, which may arise in the prosecution of the Work or CONTRACTOR'S operations under this Contract. Coverage shall be on an "occurrence" basis, and the policy shall be issued by the same insurance company that carries the CONTRACTOR'S liability insurance with a combined bodily injury and property damage minimum limit of \$1,000,000 per occurrence and \$2,000,000 aggregate.

F. "UMBRELLA" LIABILITY INSURANCE

CONTRACTOR shall obtain, pay for and maintain umbrella liability insurance during the contract term, insuring CONTRACTOR for an amount of not less than \$1,000,000 per occurrence combined limit for bodily injury and property damage that follows from and applies in excess of the primary liability coverages required hereinabove. The policy shall provide "drop down" coverage where underlying primary insurance coverage limits are insufficient or exhausted. OWNER shall be named as an additional insured.

G. RAILROAD PROTECTIVE INSURANCE

When required in the Special Provisions, CONTRACTOR shall obtain, maintain and present evidence of railroad protective insurance (RPI). The policy shall be in the name of the railroad company having jurisdiction over the right-of-way involved. The minimum limit of coverage shall meet the specifications provided by the railroad company. The OWNER shall specify the amount of RPI necessary.

H. POLICY ENDORSEMENTS AND SPECIAL CONDITIONS

1. Each insurance policy to be furnished by CONTRACTOR shall include the following conditions by endorsement to the policy:

- (a) each policy shall name the OWNER as an additional insured as to all applicable coverage;
- (b) each policy shall require that 30 days prior to the cancellation, nonrenewal or any material change in coverage, a notice thereof shall be given to OWNER by certified mail;
- (c) the term "OWNER" shall include all past, present or future, authorities, boards, bureaus, commissions, divisions, departments and offices of the OWNER and individual members, elected official, officers, employees and agents thereof in their official capacities and/or while acting on behalf of the OWNER;
- (d) the policy phrase "other insurance" shall not apply to the OWNER where the OWNER is an additional insured on the policy;
- (e) all provisions of the contract concerning liability, duty and standard of care together with the indemnification provision, shall be underwritten by contractual liability coverage sufficient to include such obligations within applicable policies;
- (f) each policy shall contain a waiver of subrogation in favor of OWNER, and its, past, present and future, officials, employees, and volunteers; and,
- (g) each certificate of insurance shall reference the Project and Contract number, contain all the endorsement required herein, and require a notice to the OWNER of cancellation.



2. Insurance furnished by the CONTRACTOR shall be in accordance with the following requirements:

(a) any policy submitted shall not be subject to limitations, conditions or restrictions deemed inconsistent with the intent of the insurance requirements to be fulfilled by the CONTRACTOR. The OWNER'S decision thereon shall be final;

(b) all policies are to be written through companies duly licensed to transact that class of insurance in the State of Texas with a financial ratings of A+ VII or better as assigned by BEST Rating Company or equivalent; and

(c) All liability policies required herein shall be written with an "occurrence" basis coverage trigger.

3. CONTRACTOR agrees to the following:

(a) CONTRACTOR hereby waives subrogation rights for loss or damage to the extent same are covered by insurance. Insurers shall have no right of recovery or subrogation against the OWNER, it being the intention that the insurance policies shall protect all parties to the Contract and be primary coverage for all losses covered by the policies;

(b) Companies issuing the insurance policies and CONTRACTOR shall have no recourse against the OWNER for payment of any premiums or assessments for any deductibles, as all such premiums and deductibles are the sole responsibility and risk of the CONTRACTOR;

(c) Approval, disapproval or failure to act by the OWNER regarding any insurance supplied by the CONTRACTOR (or any subcontractors) shall not relieve the CONTRACTOR of full responsibility or liability for damages and accidents as set forth in the Contract Documents. Neither shall the bankruptcy, insolvency or denial of liability by the insurance company exonerate the CONTRACTOR from liability; and

(d) No special payments shall be made for any insurance that the CONTRACTOR and subcontractors are required to carry; all are included in the Contract Price and the Contract unit prices. Any of such insurance policies required under this section may be written in combination with any of the others, where legally permitted, but none of the specified limits may be lowered thereby.

1.56 Vendors/Contractors/Providers must be in compliance with the provisions of Section 2270.001 of the Texas Government Code which states a governmental entity may not enter into a contract with a company for goods or services unless the contract contains a written verification from the company that it: (1) does not boycott Israel; and, (2) will not boycott Israel during the term of the contract. By submitting a response to a Collin County solicitation, the vendor will be required to sign the Chapter 2270 Verification form prior to a recommendation of the contract. This Act is effective September 1, 2017.

1.57 Vendors/Contractors/Providers must be in compliance with the provisions of Section 2252.152 and Section 2252.153 of the Texas Government Code which states, in part, contracts with companies engaged in business with Iran, Sudan, or Foreign Terrorist Organizations are prohibited. A governmental entity may not enter into a contract with a company that is listed on the Comptroller of the State of Texas website identified under Section 806.051, Section 807.051 or Section 2253.253 which do business with Iran, Sudan or any Foreign Terrorist Organization. This Act is effective September 1, 2017.

# Section 004100-Bid Form Collin County, Texas

## Bid Information

Bid Owner JD Griffin, CPPB Buyer II  
 Email jgriffin@co.collin.tx.us  
 Phone (972) 548-4116  
 Fax (972) 548-4694  
 Bid Number 2018-162  
 Title Construction, Collin County Justice Center, Upgrade Pneumatic to Electronic Actuators  
 Bid Type IFB  
 Issue Date 03/20/2018  
 Close Date 4/12/2018 02:00:00 PM (CT)

## Contact Information

Address 2300 Bloomdale Rd. Ste. 3160 McKinney, TX 75071  
 Contact JD Griffin, CPPB Buyer II  
 Department Purchasing  
 Building Admin. Building  
 Floor/Room Ste.3160  
 Telephone (972) 548-4116  
 Fax (972) 548-4694  
 Email jgriffin@co.collin.tx.us

## Ship to Information

Address 4300 Community Ave. McKinney, TX 75071  
 Contact  
 Department  
 Building Justice Center  
 Floor/Room  
 Telephone  
 Fax  
 Email

## Supplier Information

Company Name \_\_\_\_\_  
 Contact Name \_\_\_\_\_  
 Address \_\_\_\_\_  
 \_\_\_\_\_  
 Telephone \_\_\_\_\_  
 Fax \_\_\_\_\_  
 Email \_\_\_\_\_

## Supplier Notes

\_\_\_\_\_  
 \_\_\_\_\_  
 \_\_\_\_\_  
 \_\_\_\_\_  
 \_\_\_\_\_  
 \_\_\_\_\_  
 \_\_\_\_\_

The undersigned hereby certifies the foregoing bid submitted by the company listed below hereinafter called "bidder" is the duly authorized agent of said company and the person signing said bid has been duly authorized to execute same. Bidder affirms that they are duly authorized to execute this contract; this company; corporation, firm, partnership or individual has not prepared this bid in collusion with any other bidder or other person or persons engaged in the same line of business; and that the contents of this bid as to prices, terms and conditions of said bid have not been communicated by the undersigned nor by any employee or agent to any other person engaged in this type of business prior to the official opening of this bid.

Signature \_\_\_\_\_ Date \_\_\_\_/\_\_\_\_/\_\_\_\_

## Bid Notes

Please log in to view bid documents.  
 Collin County exclusively uses IonWave Technologies, Inc. (Collin County eBid) for the notification and dissemination of all solicitations. The receipt of solicitations through any other means may result in your receipt of incomplete specifications and/or addendums which could ultimately render your bid/proposal non-compliant. Collin County accepts no responsibility for the receipt and/or notification of solicitations through any other means.

## Bid Activities

Date	Name	Description
4/3/2018 02:00 PM (CT)	Mandatory Pre-Bid Conference	A MANDATORY PRE-BID CONFERENCE will be held by Collin County in the Collin County Justice Center Jail Lobby located at 4300 Community Ave, McKinney, TX 75071 on Tuesday, April 3, 2018, at 2:00 PM in order for bidders to ask questions regarding the proposed work. All bidders desiring to bid the work should have a representative at the pre-bid conference; bidders that do not attend the pre-bid conference shall not be considered in the evaluation for award of a contract per Texas Local Government Code 262.0256. Attendance shall be mandatory at the pre-bid conference.
4/6/2018 05:00 PM (CT)	Intent to Bid	Do you intend to submit a bid?

## Bid Messages

## Bid Attachments

The following attachments are associated with this opportunity and will need to be retrieved separately

#	Filename	Description
Header	LEGAL NOTICE-2018-162.doc	Legal Notice
Header	Collin County Justice Center Upgrade.pdf	Specifications
Header	Collin ADC DDC Upgrade CD's.pdf	Drawings

## Bid Attachments Requested

The following attachments are requested with this opportunity

#	Required	Specified Attachment
1	YES	<p><b>Bid Bond : BID SECURITY:</b> All Bidders must submit, prior to the bid opening time, a Cashier's Check or acceptable Bid Bond payable without recourse to Collin County in the amount of not less than five percent (5%) of the total bid plus alternates as submitted.</p> <p>1. Bid Bond or Cashier's Check may be mailed or hand delivered to the Office of the Collin County Purchasing Agent, Collin County Administration Building, 2300 Bloomdale Road, Ste 3160, McKinney, TX 75071 and shall be delivered in an envelope, marked plainly on the outside with the Bid Name and Number.</p> <p>2. Bidders submitting a bid via Collin County eBid shall upload a Bid Bond at <a href="https://collincountytx.ionwave.net">https://collincountytx.ionwave.net</a></p> <p>Regardless of delivery method, all Bid Bonds shall be received prior to the bid opening time to be considered.</p> <p>The original Bid Bond shall be received in the Collin County Purchasing Department no later than close of business on the third working day after the bid opening. Late receipt of original Bid Bond shall be cause for rejection of bid.</p>
2	NO	Conflict of Interest Questionnaire
3	YES	W-9

## Bid Attributes

Please review the following and respond where necessary

#	Name	Note	Response
1	Calendar Days Bid	Please state the consecutive calendar days bid.	_____ (Required)
2	Exceptions	Do you take exceptions to the specifications. If so, by separate attachment, please state your exceptions. Valid Responses: [Please Select], Yes, No	_____ (Required)
3	Insurance	I understand that the insurance requirements of this solicitation are required and a certificate of insurance shall be submitted to the Purchasing department if I am awarded all or a portion of the resulting contract.  Please initial.	_____ (Required)
4	Subcontractors	State the business name of all subcontractors and the type of work they will be performing under this contract.  If you are fully qualified to self-perform the entire contract, please respond with "Not Applicable-Self Perform".	_____ (Required)

- 5 Reference No. 1 List a company or governmental agency where these same/like products /services, as stated herein, have been provided. \_\_\_\_\_ (Required)
- Include the following: Company/Entity, Contact, Address, City/State/Zip, Phone, and E-Mail.
- 6 Reference No. 2 List a company or governmental agency where these same/like products /services, as stated herein, have been provided. \_\_\_\_\_ (Required)
- Include the following: Company/Entity, Contact, Address, City/State/Zip, Phone, and E-Mail.
- 7 Reference No. 3 List a company or governmental agency where these same/like products /services, as stated herein, have been provided. \_\_\_\_\_ (Required)
- Include the following: Company/Entity, Contact, Address, City/State/Zip, Phone, and E-Mail.
- 8 Cooperative Contracts As permitted under Title 8, Chapter 271, Subchapter F, Section 271.101 and 271.102 V.T.C.A. and Title 7, Chapter 791, Subchapter C, Section 791.025, V.T.C.A., other local governmental entities may wish to also participate under the same terms and conditions contained in this contract. Each entity wishing to participate must enter into an inter-local agreement with Collin County and have prior authorization from vendor. If such participation is authorized, all purchase orders will be issued directly from and shipped directly to the local governmental entity requiring supplies/services. Collin County shall not be held responsible for any orders placed, deliveries made or payment for supplies/services ordered by these entities. Each entity reserves the right to determine their participation in this contract. \_\_\_\_\_ (Required)
- Would bidder be willing to allow other local governmental entities to participate in this contract, if awarded, under the same terms and conditions?  
Valid Responses: [Please Select], Yes, No
- 9 Preferential Treatment The County of Collin, as a governmental agency of the State of Texas, may not award a contract to a nonresident bidder unless the nonresident's bid is lower than the lowest bid submitted by a responsible Texas resident bidder by the same amount that a Texas resident bidder would be required to underbid a nonresident bidder to obtain a comparable contract in the state in which the nonresident's principal place of business is located (Government Code, Title 10, V.T.C.A., Chapter 2252, Subchapter A). \_\_\_\_\_ (Required)
1. Is your principal place of business in the State of Texas?
  2. If your principal place of business is not in Texas, in which State is your principal place of business?
  3. If your principal place of business is not in Texas, does your state favor resident bidders (bidders in your state) by some dollar increment or percentage?
  4. If your state favors resident bidders, state by what dollar amount or percentage.

- 10 Debarment Certification \_\_\_\_\_ (Required)
- I certify that neither my company nor an owner or principal of my company has been debarred, suspended or otherwise made ineligible for participation in Federal Assistance programs under Executive Order 12549, "Debarment and Suspension," as described in the Federal Register and Rules and Regulations.
- Please initial.
- 11 Immigration and Reform Act \_\_\_\_\_ (Required)
- I declare and affirm that my company is in compliance with the Immigration and Reform Act of 1986 and all employees are legally eligible to work in the United States of America.
- I further understand and acknowledge that any non-compliance with the Immigration and Reform Act of 1986 at any time during the term of this contract will render the contract voidable by Collin County.
- Please initial.
- 12 Disclosure of Certain Relationships \_\_\_\_\_ (Required)
- Chapter 176 of the Texas Local Government Code requires that any vendor considering doing business with a local government entity disclose the vendor's affiliation or business relationship that might cause a conflict of interest with a local government entity. Subchapter 6 of the code requires a vendor to file a conflict of interest questionnaire (CIQ) if a conflict exists. By law this questionnaire must be filed with the records administrator of Collin County no later than the 7th business day after the date the vendor becomes aware of an event that requires the statement to be filed. A vendor commits an offense if the vendor knowingly violates the code. An offense under this section is a misdemeanor.
- By submitting a response to this request, the vendor represents that it is in compliance with the requirements of Chapter 176 of the Texas Local Government Code.
- Please send completed forms to the Collin County County Clerk's Office located at 2300 Bloomdale Rd., Suite 2104, McKinney, TX 75071.
- Please initial.
- 13 Anti-Collusion Statement \_\_\_\_\_ (Required)
- Bidder certifies that its Bid/Proposal is made without prior understanding, agreement, or connection with any corporation, firm, or person submitting a Bid/Proposal for the same materials, services, supplies, or equipment and is in all respects fair and without collusion or fraud.
- No premiums, rebates or gratuities permitted; either with, prior to, or after any delivery of material or provision of services. Any such violation may result in Agreement cancellation, return of materials or discontinuation of services and the possible removal from bidders list.
- Please initial.
- 14 Disclosure of Interested Parties \_\_\_\_\_ (Required)
- Section 2252.908 of the Texas Government Code requires a business entity entering into certain contracts with a governmental entity to file with the governmental entity a disclosure of interested parties at the time the business entity submits the signed contract to the governmental entity. Section 2252.908 requires the disclosure form (Form 1295) to be signed by the authorized agent of the contracting business entity, acknowledging that the disclosure is made under oath and under penalty of perjury. Section 2252.908 applies only to a contract that

requires an action or vote by the governing body of the governmental entity before the contract may be signed or has a value of at least \$1 million. Section 2252.908 provides definitions of certain terms occurring in the section.

Section 2252.908 applies only to a contract entered into on or after January 1, 2016.

Please initial.

15 Notification Survey \_\_\_\_\_ (Required)  
In order to better serve our offerors, the Collin County Purchasing Department is conducting the following survey. We appreciate your time and effort expended to submit your bid. Should you have any questions or require more information please call (972) 548-4165.

How did you receive notice of this request?

Valid Responses: [Please Select], Plano Star Courier, Plan Room, Collin County eBid Notification, Collin County Website, Other

16 Bid Bond Acknowledgement \_\_\_\_\_ (Required)  
Accompanying this bid, is a certified check, cashier's check or Bid Bond in the amount of five percent (5%) of the total amount bid. Also accompanying this bid, all the information required in Section 00200 – Instructions to Bidders.

Please initial.

17 Construction Acknowledgement \_\_\_\_\_ (Required)  
Bidder, declares that the only person or parties interested in this bid are those principals named herein, that his/her bid is made without collusion with any other person, firm or corporation, that he/she has carefully examined the Contract Documents including the Advertisement for Bids, Instruction to Bidders, Construction Agreement, Specifications and the Drawings, therein referred to and has carefully examined the locations, conditions and classes of materials for the proposed work, and agrees that he/she will provide all the necessary labor, machinery, tools, equipment, apparatus and other items incidental to construction and will do all the work and furnish all the materials called for in the Contract Documents in the manner prescribed therein.

Bidder hereby declares that he/she has visited the site of the Work and has carefully examined the Contract Documents pertaining to the Work covered by the above Bid, and he/she further agrees to commence work within ten (10) consecutive calendar days after date of written Notice to Proceed and to substantially complete the work on which he/she has bid within the number of days specified subject to such extensions of time allowed by Specifications.

Bidder certifies that the bid prices contained in this bid have been carefully checked and are submitted as correct and final. The prices have been shown in words and figures for each item listed in this bid and it is understood that in the event of a discrepancy, the words shall govern.

Please initial.

Line Items

#	Qty	UOM	Description	Response
1	1	lump sum	Bid Grand Total	\$ _____ (Required) Price

Supplier Notes: \_\_\_\_\_  
\_\_\_\_\_

Item Attributes: Please review the following and respond where necessary

#	Name	Note	Response
1	Bid Grand Total- Written in Words	The contract award will be based on the total bid price.	_____ (Required)
2	Total Material Cost Incorporated in Project		\$ _____ (Required)
3	Total Material Cost Incorporated in Project- Written in Words		_____ (Required)
4	Total Labor Cost Incorporated in Project		\$ _____ (Required)
5	Total Labor Cost Incorporated in Project- Written in Words		_____ (Required)

**004313 BID BOND**

STATE OF TEXAS §  
COUNTY OF COLLIN §

**KNOW ALL MEN BY THESE PRESENTS:**

**THAT** \_\_\_\_\_, a corporation organized and existing under the laws of the State of \_\_\_\_\_, and fully authorized to transact business in the State of Texas, whose address is \_\_\_\_\_ of the City of \_\_\_\_\_ County of \_\_\_\_\_, and State of \_\_\_\_\_, (hereinafter referred to as "Principal"), and \_\_\_\_\_ (hereinafter referred to as "Surety", a corporation organized under the laws of the State of \_\_\_\_\_ and authorized under the laws of the State of Texas to act as surety on bonds for principals, are held and firmly bound unto \_\_\_\_\_ (hereinafter referred to as "Owner") and unto all persons, firms and corporations who may furnish materials for or perform labor upon the buildings, structures or improvements referred to in the attached Contract, in the penal sum of \_\_\_\_\_ Dollars (\$ \_\_\_\_\_) in lawful money of the United States, for the payment whereof, the said Principal and Surety bind themselves, and their heirs, administrators, executors, successors, and assigns, jointly and severally, firmly by these presents:

**SIGNED, SEALED and DATED** this \_\_\_\_\_ day of \_\_\_\_\_ 20\_\_\_\_\_.

**WHEREAS**, the Principal is herewith submitting its proposal for IFB 2018-162, Construction, Collin County Justice Center, Upgrade Pneumatic to Electronic Actuators.

The condition of the above obligations are such that if the aforesaid Principal shall be awarded the Contract, the said Principal will, within the time required, enter into a Contract and give Bonds, if required, for the faithful performance of the Contract and the prompt payment for labor and materials in the prosecution thereof, then this obligation shall be null and void; otherwise the Principal and Surety will pay unto the OWNER the full penal sum hereof, as liquidated damages, it being difficult and impractical to determine accurately the actual amount of damages occurring to OWNER by reason of Principal's failure to execute said Contract and Bonds.

PROVIDED FURTHER, that if any legal action be filed on this Bond, venue shall lie in \_\_\_\_\_ County, Texas.

The Resident Agent of the Surety for delivery of notice and service of process is:  
Name: \_\_\_\_\_  
Address: \_\_\_\_\_  
Phone Number: \_\_\_\_\_

**WITNESS**

\_\_\_\_\_

**PRINCIPAL**

\_\_\_\_\_

Printed/Typed Name \_\_\_\_\_

Title: \_\_\_\_\_

Company: \_\_\_\_\_

Address: \_\_\_\_\_

**SURETY**

\_\_\_\_\_

Printed/Typed Name \_\_\_\_\_

Title: \_\_\_\_\_

Company: \_\_\_\_\_

Address: \_\_\_\_\_

**WITNESS**

\_\_\_\_\_

**NOTE: CERTIFIED COPY OF POWER-OF-ATTORNEY SHOULD BE ATTACHED HERETO.**

**Revised 11/2008**



**SECTION 004547-CONFLICT OF INTEREST**  
**INFORMATION REGARDING**  
**CONFLICT OF INTEREST QUESTIONNAIRE**

During the 79<sup>th</sup> Legislative Session, House Bill 914 was signed into law effective September 1, 2015, which added Chapter 176 to the Texas Local Government Code. Recent changes have been made to Chapter 176 pursuant to HB23, which passed the 84<sup>th</sup> Legislative Session. Chapter 176 mandates the public disclosure of certain information concerning persons doing business or seeking to do business with Collin County, including family, business, and financial relationships such persons may have with Collin County officers or employees involved in the planning, recommending, selecting and contracting of a vendor for this procurement.

For a copy of Form CIQ and CIS:

[http://www.ethics.state.tx.us/filinginfo/conflict\\_forms.htm](http://www.ethics.state.tx.us/filinginfo/conflict_forms.htm)

The vendor acknowledges by doing business or seeking to do business with Collin County that he/she has been notified of the requirements under Chapter 176 of the Texas Local Government Code and that he/she is solely responsible for complying with the terms and conditions therein. Furthermore, any individual or business entity seeking to do business with Collin County who does not comply with this practice may risk award consideration of any County contract.

For a listing of current Collin County Officers:

<http://www.collincountytexas.gov/government/Pages/officials.aspx>

The following County employees will be involved in the planning, recommending, selecting, and contracting for the attached procurement:

Department/Evaluation Team:

Bill Burke - Director of Building Projects

Brad Harris - Building Projects Coordinator

Purchasing:

Michalyn Rains, CPPO, CPPB – Purchasing Agent

Michelle Charnoski, CPPB – Assistant Purchasing Agent

J. D. Griffin, CPPB – Buyer II

Commissioners' Court:

Keith Self – County Judge

Susan Fletcher – Commissioner Precinct No. 1

Cheryl Williams – Commissioner Precinct No. 2

John Thomas – Commissioner Precinct No. 3

Duncan Webb – Commissioner Precinct No. 4

# CONFLICT OF INTEREST QUESTIONNAIRE

For vendor doing business with local governmental entity

**FORM CIQ**

This questionnaire reflects changes made to the law by H.B. 23, 84th Leg., Regular Session.

This questionnaire is being filed in accordance with Chapter 176, Local Government Code, by a vendor who has a business relationship as defined by Section 176.001(1-a) with a local governmental entity and the vendor meets requirements under Section 176.006(a).

By law this questionnaire must be filed with the records administrator of the local governmental entity not later than the 7th business day after the date the vendor becomes aware of facts that require the statement to be filed. See Section 176.006(a-1), Local Government Code.

A vendor commits an offense if the vendor knowingly violates Section 176.006, Local Government Code. An offense under this section is a misdemeanor.

**OFFICE USE ONLY**

Date Received

**1** Name of vendor who has a business relationship with local governmental entity.

**2**  Check this box if you are filing an update to a previously filed questionnaire. (The law requires that you file an updated completed questionnaire with the appropriate filing authority not later than the 7th business day after the date on which you became aware that the originally filed questionnaire was incomplete or inaccurate.)

**3** Name of local government officer about whom the information is being disclosed.

\_\_\_\_\_  
Name of Officer

**4** Describe each employment or other business relationship with the local government officer, or a family member of the officer, as described by Section 176.003(a)(2)(A). Also describe any family relationship with the local government officer. Complete subparts A and B for each employment or business relationship described. Attach additional pages to this Form CIQ as necessary.

A. Is the local government officer or a family member of the officer receiving or likely to receive taxable income, other than investment income, from the vendor?

Yes       No

B. Is the vendor receiving or likely to receive taxable income, other than investment income, from or at the direction of the local government officer or a family member of the officer AND the taxable income is not received from the local governmental entity?

Yes       No

**5** Describe each employment or business relationship that the vendor named in Section 1 maintains with a corporation or other business entity with respect to which the local government officer serves as an officer or director, or holds an ownership interest of one percent or more.

**6**  Check this box if the vendor has given the local government officer or a family member of the officer one or more gifts as described in Section 176.003(a)(2)(B), excluding gifts described in Section 176.003(a-1).

**7**

\_\_\_\_\_  
Signature of vendor doing business with the governmental entity

\_\_\_\_\_  
Date

## **CONFLICT OF INTEREST QUESTIONNAIRE**

### **For vendor doing business with local governmental entity**

A complete copy of Chapter 176 of the Local Government Code may be found at <http://www.statutes.legis.state.tx.us/Docs/LG/htm/LG.176.htm>. For easy reference, below are some of the sections cited on this form.

**Local Government Code § 176.001(1-a):** "Business relationship" means a connection between two or more parties based on commercial activity of one of the parties. The term does not include a connection based on:

- (A) a transaction that is subject to rate or fee regulation by a federal, state, or local governmental entity or an agency of a federal, state, or local governmental entity;
- (B) a transaction conducted at a price and subject to terms available to the public; or
- (C) a purchase or lease of goods or services from a person that is chartered by a state or federal agency and that is subject to regular examination by, and reporting to, that agency.

**Local Government Code § 176.003(a)(2)(A) and (B):**

(a) A local government officer shall file a conflicts disclosure statement with respect to a vendor if:

\*\*\*

(2) the vendor:

(A) has an employment or other business relationship with the local government officer or a family member of the officer that results in the officer or family member receiving taxable income, other than investment income, that exceeds \$2,500 during the 12-month period preceding the date that the officer becomes aware that

- (i) a contract between the local governmental entity and vendor has been executed;
- or
- (ii) the local governmental entity is considering entering into a contract with the vendor;

(B) has given to the local government officer or a family member of the officer one or more gifts that have an aggregate value of more than \$100 in the 12-month period preceding the date the officer becomes aware that:

- (i) a contract between the local governmental entity and vendor has been executed; or
- (ii) the local governmental entity is considering entering into a contract with the vendor.

**Local Government Code § 176.006(a) and (a-1)**

(a) A vendor shall file a completed conflict of interest questionnaire if the vendor has a business relationship with a local governmental entity and:

- (1) has an employment or other business relationship with a local government officer of that local governmental entity, or a family member of the officer, described by Section 176.003(a)(2)(A);
- (2) has given a local government officer of that local governmental entity, or a family member of the officer, one or more gifts with the aggregate value specified by Section 176.003(a)(2)(B), excluding any gift described by Section 176.003(a-1); or
- (3) has a family relationship with a local government officer of that local governmental entity.

(a-1) The completed conflict of interest questionnaire must be filed with the appropriate records administrator not later than the seventh business day after the later of:

(1) the date that the vendor:

- (A) begins discussions or negotiations to enter into a contract with the local governmental entity; or
- (B) submits to the local governmental entity an application, response to a request for proposals or bids, correspondence, or another writing related to a potential contract with the local governmental entity; or

(2) the date the vendor becomes aware:

- (A) of an employment or other business relationship with a local government officer, or a family member of the officer, described by Subsection (a);
- (B) that the vendor has given one or more gifts described by Subsection (a); or
- (C) of a family relationship with a local government officer.

## SECTION 004548-CHAPTER 2270 VERIFICATION

I, \_\_\_\_\_, the undersigned representative of  
(PRINT NAME)

\_\_\_\_\_  
(COMPANY)

do hereby verify that the company named-above, under the provisions of Subtitle F, Title 10, Government Code Chapter 2270:

1. Does not boycott Israel currently; and
2. Will not boycott Israel during the term of the contract.

*Pursuant to Section 2270.001, Texas Government Code:*

1. *“Boycott Israel” means refusing to deal with, terminating business activities with, or otherwise taking any action that is intended to penalize, inflict economic harm on, or limit commercial relations specifically with Israel, or with a person or entity doing business in Israel or in an Israeli-controlled territory, but does not include an action made for ordinary business purposes; and*
2. *“Company” means a for-profit sole proprietorship, organization, association, corporation, partnership, joint venture, limited partnership, limited liability partnership, or any limited liability company, including a wholly owned subsidiary, majority-owned subsidiary, parent company or affiliate of those entities or business associations that exist to make a profit.*

\_\_\_\_\_  
DATE

\_\_\_\_\_  
SIGNATURE OF COMPANY REPRESENTATIVE

\_\_\_\_\_  
TITLE

## 005213 CONSTRUCTION AGREEMENT

THIS CONSTRUCTION AGREEMENT is made and entered into by and between \_\_\_\_\_, a \_\_\_\_\_ corporation (hereinafter referred to as "Contractor"), and **COLLIN COUNTY, TEXAS**, a political subdivision of the State of Texas (hereinafter referred to as "County" or "OWNER"), to be effective from and after the date hereinafter provided.

For and in consideration of the covenants and agreements contained herein, and for the mutual benefits to be obtained hereby, the parties hereto agree as follows:

### CONTRACT SUM

The County shall pay the Contractor in current funds for the performance of the work, subject to additions and deductions by Change orders as provided in the Contract Documents. The contract sum shall be the amount of (\$ \_\_\_\_\_).

### EFFECTIVE DATE

This Construction Agreement, having been previously approved by the Commissioners' Court of Collin County, Texas, shall be effective upon the date of delivery and execution by Contractor, provided the County executes the same within five (5) consecutive calendar days after said delivery and execution by Contractor.

## I. CONTRACT GENERAL PROVISIONS

### 1.1 DEFINITIONS

Words which have well-known technical or construction industry meanings shall have their commonly understood meanings in the Contract Documents, unless a different meaning is stated in the Contract Documents. The following words and expressions, or pronouns used in their place, shall wherever they appear in this contract be construed as follows, unless a different meaning is clear from the context:

**Addendum, Bulletin or Letter of Clarification:** Any additional contract provisions, or change, revisions or clarification of the Contract Documents issued in writing by the OWNER, to prospective bidders prior to the receipt of bids.

**Contract or Contract Documents:** The written agreement covering the performance of the work. The Contract and Contract Documents include this written Construction Agreement between OWNER and CONTRACTOR, Advertisement for Bids, Instructions to Bidders, Requests for Proposal, all Addenda, the Specifications, including the general and supplemental special and technical conditions, Drawings, provisions, plans or working drawings — and any supplemental changes or agreements pertaining to the Work or materials therefor; and bonds and any additional documents incorporated by reference in the above.

**CONTRACTOR:** The person, persons, partnership, firm, corporation, association or organization, or any combination thereof, entering into the contract for the execution of the work, acting directly or through a duly authorized representative.

**Other CONTRACTORS:** Any contractor, other than the CONTRACTOR or his subcontractors, who has a direct contact with the OWNER for work on or adjacent to the site of the work.

**Contract Work or Work:** Everything expressly or impliedly required to be furnished and done by the CONTRACTOR by the Contract Documents.

**Architect:** The term “Architect” means the Architect or his duly authorized representative. The Architect shall be understood to be the Architect of the OWNER, and nothing contained in the Contract Documents shall create any contractual or agency relationship between the Architect and the CONTRACTOR.

**Extra Work:** Work other than that which is expressly or impliedly required by the Contract Documents at the time of the execution of the contract.

**Change Order:** A written order to the CONTRACTOR authorizing and directing an addition, deletion or revision in the work within the general scope of the Contract Documents, or authorizing an adjustment in the Contract Price or the Contract time.

**Contract Price:** The total amount of money payable to the CONTRACTOR under the terms and conditions of the Contract Documents. When used in such context, it may also mean the unit price of an item of work under the Contract terms.

**OWNER’S Representative:** The Architect or other duly authorized assistant, agent, engineer, inspector or superintendent acting within the scope of their particular duties.

**Drawings or Contract Drawings:** Those drawings that are the graphic and pictorial portions of the Contract Documents showing the design, location and dimensions of the Work, including but not limited to, the plans, elevations, sections, details, schedules, diagrams, any bulletin, or any detailed drawing furnished by the OWNER, pertaining or supplemental thereto.

**Specifications:** Those portions of the Contract Documents that specify the requirements for materials, equipment, systems, standards and workmanship for performance of the Work, and related services.

**Inspector:** Any representative of the OWNER designated to inspect the work.

**Materialman or Supplier:** Any subcontractor contracting with the CONTRACTOR, or any of his subcontractors, to fabricate or deliver or who actually fabricates or delivers materials, supplies or equipment to be consumed or incorporated into the Work.

**Notice:** Written notice effective the date of the postmark thereon, or if hand delivered, effective the date of hand delivery.

**OWNER:** COLLIN COUNTY, TEXAS, a political subdivision of the State of Texas. The term OWNER means the OWNER or its authorized representative.

**Payment Bond:** A bond in the amount of the Contract executed by a corporate surety in accordance with all Texas Law, including but not limited to, Chapter 2253 of the Texas Government Code and Chapter 3503 of the Texas Insurance Code, for public works projects as security furnished by the CONTRACTOR and his sureties solely for the protection of payment bond beneficiaries supplying labor and materials in the prosecution of the Contract Work.

**Performance Bond:** A bond in the amount of the Contract executed by a corporate surety in accordance with all Texas Law, including but not limited to, Chapter 2253 of the Texas Government Code and Chapter 3503 of the Texas Insurance Code, for public works projects as security furnished by the CONTRACTOR and his sureties solely for the protection of the Owner, conditioned on the faithful performance of the Contract Work in accordance with the plans, specification, and Contract Documents.

**Maintenance Bond:** A bond executed by a corporate surety for 10% of the Contract Price that complies with all Texas Laws, including but not limited to, Chapter 3503 of the Texas Insurance Code, guaranteeing the prompt, full and faithful performance of the general guaranty and warranty contained in the Contract Documents, and Texas Law.

**Project:** The total construction of the work described in the Contract Documents performed by the Contractor, Other Contractor or the Owner in whole or part.

**Proposal:** The written statement or statements duly submitted to the OWNER by the person, persons, partnership, company, firm, association or corporation proposing to do the Work contemplated, including the approved form on which the formal bids for the Work are to be proposed.

**Plan, or Plans:** The plans are the drawings or reproductions therefrom made by the Owner or Owner's Representative and approved by the Owner showing the dimensions, location, design and position of the various elements of the Project and Work, including plans, elevations, sections, details, schedules, diagrams, working drawings, preliminary drawings, and such supplemental drawings as the Owner may issue to clarify other drawings or for the purpose of showing changes in the Contract Work authorized by the Owner, or for showing details not shown therein.

**Special Provisions or Conditions:** The special clauses of the Contract, or Contract Documents, setting forth conditions or requirements peculiar to the specific Project involved, supplementing the standard or general specifications and taking precedence over any conditions or requirements of the standard or general specifications with which they are in conflict.

**Specifications or Contract Specifications:** All of the general, special and technical conditions or provisions, and all addendum or supplements thereto consisting of written requirements for materials, equipment, systems, standards and performance of the work.

**Site:** The area upon or in which the CONTRACTOR'S operations are carried on, and such other areas adjacent thereto as may be designated as such by the OWNER.

**Subcontractors:** Any persons, firm or corporation, other than employees of the CONTRACTOR, who or which contracts with the CONTRACTOR to furnish, or who actually furnishes, labor and/or materials and equipment at or about the site.

**Sureties:** The corporate bodies which are bound by such bonds as are required with and for the CONTRACTOR. The sureties engaged to be responsible for the entire and satisfactory fulfillment of the Contract and for any and all requirements as set out in the specifications, Contract or plans.

**The Work:** All work including the furnishing of all labor, materials, tools, equipment, required submittals and incidentals to be performed by the CONTRACTOR under the terms of the Contract.

**Directed, Required, Approved and Words of Like Import:** Whenever they apply to the Work or its performance, the words "directed," "required," "permitted," "ordered," "designated," "established," "prescribed" and words of like import used in the Contract, specifications or upon the drawings shall imply the direction, requirement, permission, order, designation or prescription of the OWNER; and "approved," "acceptable," "satisfactory" and words of like import shall mean approved by, acceptable to or satisfactory to the OWNER.

**Equal:** Materials, articles or methods which are of equal or higher quality than those specified or shown on the drawings and as further defined in the "or equal" clause. Substitution of Materials shall be determined by the Architect at his or her discretion, and approved by the Owner.

**Working Time, Completion Time or Contract Time:** The time set forth in the Contract for the performance and completion of the Work contracted for. The time may be expressed as calendar days, working days or a specific date.

**Calendar Day or Days:** Any successive days of the week or month, no days being excepted.

**Working Day:** A working day is defined as a calendar day not including Saturdays, Sundays or those legal holidays as specified in the list prepared by the OWNER for contract purposes. Nothing in this definition shall be construed as prohibiting the CONTRACTOR from working on Saturdays if he so desires, however permission of the OWNER shall be necessary if the CONTRACTOR chooses to work on Saturday. Work on Sundays shall not be permitted without the written permission of the OWNER. If Saturday or Sunday work is permitted, working time shall be charged on the same basis as week days. Where the working time is



expressed as calendar days or a specific date, the concept of working days shall no longer be relevant to the contract.

## **CONTRACT DOCUMENTS**

- 1.2 The parties agree that the Contract Documents shall consist of the following documents in addition to any other documents referenced or incorporated herein:
- A. This written Construction Agreement, including any changes or modifications;
  - B. All addenda including the following listed and numbered addenda:  
Addendum No. 1 dated \_\_\_\_\_ Received \_\_\_\_\_  
Addendum No. 2 dated \_\_\_\_\_ Received \_\_\_\_\_  
Addendum No. 3 dated \_\_\_\_\_ Received \_\_\_\_\_
  - C. Advertisement for Bids, Instructions to Bidder, the Invitation to Bid and Bid Form;
  - D. The Special/Supplemental Conditions;
  - E. The Specifications and the Project Drawings (if any);
  - F. The Construction Details shown on plans;
  - G. The Standard Specifications and Standard Drawings from the Public Works Construction Standards-North Central Texas Council of Governments, 2004 edition and all subsequent addendums;
  - H. The Performance Bond in the sum of ONE HUNDRED PERCENT (100%) of the total Contract Price;
  - I. The Payment Bond in the sum of ONE HUNDRED PERCENT (100%) of the total Contract Price; and,
  - J. The Maintenance Bond in the sum of TEN PERCENT (10%) of the total Contract Price.

### 1.2.1 PRIORITY OF THE CONTRACT DOCUMENTS

These Contract Documents (A through J above) form the Construction Agreement and are a part of this Construction Agreement as if fully set forth herein. In the event of an inconsistency in any of the provisions of the Contract Documents, the inconsistency shall be resolved by giving precedence to the Contract Documents in the order in which they are listed above.

### 1.2.2 THE CONTRACT

The Contract Documents form the Contract. The Contract represents the entire integrated agreement between the OWNER and the CONTRACTOR and supercedes all prior negotiations, and representations by either party.

## 1.3 CORRELATION AND INTENT OF DOCUMENTS

The Contract Documents are complementary and what is called for by any one shall be as binding as if called for by all. The intent of the documents, unless otherwise specifically provided, is to produce complete and finished work, which the CONTRACTOR undertakes to do in full compliance with the Contract Documents. It is not intended to mention every item of work in the specifications which can be adequately shown on the drawings nor to

show on the drawings all items of work described or required by the specifications. All materials or labor for work shown on the drawings or reasonably inferable therefrom as being necessary to produce a finished job shall be provided by the CONTRACTOR whether or not same is expressly covered in the specifications. No verbal conversation, understanding or agreement with any officer or employee or agent of the OWNER, either before or after the execution of the Contract, shall affect or modify any of the terms, conditions or obligations contained in the Contract Documents.

#### 1.3.1 CONTRACT DRAWINGS AND SPECIFICATIONS

The OWNER shall furnish the CONTRACTOR one copy of the Contract Drawings and any supplemental drawings and specifications reasonably necessary for the proper execution of the work. At least one copy of all drawings and specifications shall be accessible at all times to the OWNER at the job site.

#### 1.3.2 SUPPLEMENTAL DRAWINGS AND SPECIFICATIONS

In order to carry out the intent of the Contract Documents and to assist the CONTRACTOR in performing its work, the OWNER, after the execution of the Contract, may, by supplemental drawings, specifications or otherwise, furnish additional information or instructions as may be necessary for construction purposes.

All such supplemental drawings, specifications or instructions are intended to be consistent with the Contract Documents and reasonably inferable therefrom. Therefore, no extra costs shall be allowed by the OWNER on a claim that particular supplemental drawings, specifications or instructions differ from the requirements of the Contract Documents, incurring extra costs, unless the CONTRACTOR has first brought the matter, in writing, to the OWNER'S attention for adjustment before proceeding with the work covered by such.

If the OWNER decides that there is no departure from the requirements of the Contract Documents, the CONTRACTOR shall then proceed with the work as shown, specified or directed. If the OWNER shall decide that extra work is involved, he shall so modify the supplemental drawings, specifications or instructions to eliminate the extra work, or cause a written Change Order to be issued in accordance with the Contract Documents.

#### 1.3.3 ERRORS AND CORRECTIONS IN DRAWINGS AND SPECIFICATIONS

The CONTRACTOR shall not take advantage of any apparent errors, omissions or discrepancies in the drawings or specifications; and the Architect or Engineer shall be permitted to make such corrections or interpretations as may be necessary for the fulfillment of the intent of the Contract Documents. In case of any errors, omissions or discrepancies in the drawings or specifications, the CONTRACTOR shall promptly submit the matter to the OWNER or OWNER'S Representative in

writing who, in turn, shall promptly make a determination and issue the necessary instructions in writing. Any adjustment by the CONTRACTOR without this determination and instructions shall be at the CONTRACTOR'S own risk and expense. The Work is to be made complete as intended by the Contract Documents.

#### 1.3.4 EXISTING STRUCTURES

The plans show the general locations of some known surface and subsurface structures. The locations of many gas mains, water mains, conduits, sewers, other utilities, etc., however, are unknown, and the OWNER assumes no responsibility for failure to show any or all of these structures on the plans or to show them in their exact locations. It is mutually agreed that such failure shall not be considered sufficient basis for claims for additional compensation for Extra Work or for increasing the pay quantities in any manner whatsoever. The CONTRACTOR shall be solely responsible for locating all gas mains, water mains, conduits, sewers, other utilities etc., so as to perform the Work without damaging the same.

## II. THE WORK

### 2.1 SCOPE OF WORK

Contractor shall provide all labor, supervision, materials, and equipment necessary to perform all work required by the Contract Documents in connection with **IFB 2018-162, Construction, Collin County Justice Center, Upgrade Pneumatic to Electronic Actuators.**

### 2.2 CHANGE OR MODIFICATION OF CONTRACT

#### 2.2.1 ALTERATION OF PLANS AND SPECIFICATIONS

The OWNER reserves the right to make such changes in the plans and specifications and in the character of the work as may be necessary or desirable to insure completion in the most satisfactory manner, provided such changes do not materially alter the original plans and specifications or change the general nature of the Work as a whole. Such changes shall not be considered as waiving or invalidating any condition or provision of the Contract or bonds. Such changes shall be issued by the Architect.

#### 2.2.2 INCREASED OR DECREASED QUANTITIES OF WORK

The OWNER reserves the right and may from time to time, by written order, and without notice to any surety, make changes in the quantity or time of performance of the Work, as may be considered necessary or desirable and such changes shall not be considered as waiving or invalidating any conditions or provisions of the Contract or bonds. The CONTRACTOR shall perform all the Contract Work in strict compliance with the Contract Documents, and shall not make any changes to the Work without prior written authorization from the OWNER, in the form of a written Change Order. If such changes increase or decrease either the cost or the

time necessary for the performance of the Work, then the parties will mutually agree upon an equitable adjustment to the price or time to perform the Work pursuant to the terms of the Contract.

### 2.2.3 EXTRA WORK/CHANGE ORDERS

When any work is necessary to the proper completion of the Project and for which no prices are provided for in the Bid or Proposal and Contract, the CONTRACTOR shall do such work, but only when and as ordered in writing by the OWNER. The OWNER may order changes in the Work without invalidating Contract. Payment for Extra Work shall be made as provided herein. Contractor agrees that overhead and profit for Extra Work shall not exceed 10% of the total cost of the Extra Work. The Contractor shall not be entitled to any additional funds for any work or extra work performed on the Project, unless a Change Order is issued and signed by the Owner. The CONTRACTOR shall perform the work as altered, whether increased or decreased, and no allowances shall be made for anticipated profits. Nothing in this section shall give rise to any claims for any delay or acceleration damages, and the CONTRACTORS sole remedy for any delays in the Project shall remain an equitable extension of time as provided for in the Contract Documents. CONTRACTOR acknowledges and agrees to waive all rights or claims for compensation for any additional or other work not specifically authorized by the OWNER.

## 2.3 DISPUTED WORK AND CLAIMS FOR ADDITIONAL COMPENSATION

If the CONTRACTOR is of the opinion that (a) the work necessary or required to accomplish the result intended by this Contract, or (b) any work ordered to be done as Contract Work by the OWNER is extra work or additional work and not Contract Work, or (c) any determination or order of the OWNER violates the terms and provisions of this Contract, the CONTRACTOR shall promptly, either before proceeding with such work or complying with such order or determination, notify the OWNER in writing of his contentions with respect thereto and request a final determination thereof.

Such determination of the OWNER shall be given in writing to the CONTRACTOR. If the OWNER determines that the work in question is Extra Work and not Contract Work, or that the order complained of requires performance by the CONTRACTOR beyond that required by the Contract or violates the terms and provisions of the Contract, thereupon the OWNER shall cause either (a) the issuance of a written Change Order covering the Extra Work as provided herein, or (b) the determination or order complained of to be rescinded or so modified so as to not require performance beyond that required by the terms and provisions of the Contract.

If the OWNER determines that the work in question is Contract Work and not Extra Work, or that the determination or order complained of does not require performance by the CONTRACTOR beyond that required by the Contract or violate the terms and provisions of the Contract, he shall direct the CONTRACTOR to proceed, and the CONTRACTOR must promptly comply. In order to reserve his right to claim compensation for such work

resulting from such compliance, however, the CONTRACTOR must, within 20 calendar days after receiving the OWNER'S determination and direction, notify the OWNER in writing that the work is being performed, or that the determination and direction is being complied with, under protest.

If the CONTRACTOR fails to so appeal to the OWNER for a determination or, having so appealed, should the CONTRACTOR thus fail to notify the OWNER in writing of his protest, the CONTRACTOR shall be deemed to have waived any claim for extra compensation or damages therefore. No oral appeals or oral protests, no matter to whom made, shall be deemed even substantial compliance with the provisions of this item.

In addition to the foregoing requirements, the CONTRACTOR shall, upon notice from the OWNER, for a minimum period of three (3) years following final payment or termination of contract, produce for examination and audit at the CONTRACTOR'S office, by the representatives of the OWNER, all his books and records showing all of his acts and transactions in connection with contractual performance as well as relating to or arising by reason of the matter in dispute. At such examination a duly authorized representative of the CONTRACTOR may be present.

Unless the aforesaid requirements and conditions are complied with by the CONTRACTOR, the OWNER shall be released from all claims arising under, relating to or by reason of disputed work or extra work. It is further stipulated and agreed that no conduct on the part of the OWNER or any agent or employee of the OWNER shall ever be construed as a waiver of the requirements of this section, when such requirements constitute an absolute condition precedent to any approval of any claim for extra compensation, notwithstanding any other provisions of the Contract Documents; and in any action against the OWNER to recover any sum in excess of the contract amount, the CONTRACTOR must allege and prove strict compliance with the provisions of this section. The CONTRACTOR ASSUMES THE RISK OF NONPAYMENT, for failing to comply with any of the requirements of this section.

### **III. CONTRACTORS RESPONSIBILITIES**

#### **3.1 CONTRACTOR'S REPRESENTATIONS, WARRANTIES AND ASSURANCES.**

In consideration of, and to induce the award of this contract to him, the CONTRACTOR represents and warrants: (a) That he is financially solvent, and sufficiently experienced and competent to perform the work; (b) That the facts stated in the proposal and the information given by him pursuant to the bidding documents are true and correct in all respects; (c) That he has read, understood and complied with all the requirements set forth in the bidding documents; (d) That he is familiar with and understands all laws and regulations applicable to the work; and (e) unless otherwise specifically provided for in the Contract Documents, the CONTRACTOR shall do all the Work and shall furnish all the tools, equipment, machinery, materials, labor and appliances, except as herein otherwise specified, necessary or proper for performing and completing the work required by this Contract, in the manner and within the time herein prescribed.

By executing the contract, the CONTRACTOR represents that he has visited the site of Work, has fully familiarized himself with the local and on-site conditions under which the work is to be performed and has correlated his observation with the requirements of the Contract Documents. In addition, the CONTRACTOR represents that he has satisfied himself as to subsurface conditions at the site of the Work. Information, data and representations contained in the Contract Documents pertaining to the conditions at the site, including subsurface conditions, are for information only and are not warranted or represented in any manner to accurately show the conditions at the site of the Work. The CONTRACTOR agrees that he shall make no claims for damages, additional compensation or extension of time against the OWNER because of encountering actual conditions in the course of the Work which vary or differ from conditions or information contained in the Contract Documents. All risks of differing subsurface conditions shall be borne solely by the CONTRACTOR.

The CONTRACTOR shall carefully study and compare the Contract Documents and shall at once report to the OWNER any error, inconsistency or omission he may discover. The CONTRACTOR shall perform no portion of the Work at any time without Contract Documents or, where required, approved shop drawings, product data or samples for such portion of the work.

### 3.1.1 SHOP DRAWINGS, PRODUCT DATA AND SAMPLES

A. Shop drawings are drawings, diagrams, schedules and other data specially prepared for the work by the CONTRACTOR or any subcontractor, manufacturer, supplier or distributor to illustrate some portion of the Work.

B. Product data are illustrations, standard schedules, performance charts, instructions, brochures, diagrams and other information furnished by the CONTRACTOR to illustrate a material, product or system for some portion of the work.

C. Samples are physical examples which illustrate materials, equipment or workmanship and establish standards by which the work shall be judged.

D. the CONTRACTOR shall provide, review, approve and submit to the Architect with reasonable promptness and in such sequence as to cause no delay in the Work or in the work of the OWNER or any separate contractor, all shop drawings, product data and samples required by the Contract Documents. The Work will be performed in accordance with submittals approved by the Architect. The CONTRACTOR shall not be relieved responsibility for deviations from the requirements of the Contract Documents by errors or omissions by the OWNER or Architect in approving Shop Drawings, Product Data, samples or any other submittals.

E. By approving and submitting shop drawings, product data and samples, the CONTRACTOR represents that he has determined and verified all materials, field measurements, and field construction criteria related thereto, or shall do so, and that he has checked and coordinated the information contained within such submittals with the requirements of the Work and of the Contract Documents.

F. As the Architect's review is only for general conformance with the requirements of the Contract Documents, the CONTRACTOR shall not be relieved of responsibility for any deviation from the requirements of the Contract Documents by the Architect's approval of shop drawings, product data or samples unless the CONTRACTOR has specifically informed the Architect in writing of such deviation at the time of submission and the Architect have given written approval to the specific deviation. The CONTRACTOR shall not be relieved from responsibility for errors or omissions in the shop drawings, product data or samples by the Architect's approval thereof. The CONTRACTOR shall direct specific attention, in writing or on resubmitted shop drawings, product data or samples, to revisions other than those requested by the Architect on previous submittals.

G. the CONTRACTOR shall be responsible for delays caused by rejection of the submittal of inadequate or incorrect shop drawings, product data or samples. The CONTRACTOR shall be responsible for seeing that any "approved" copies of shop drawings bearing the approval of the Architect are allowed on the job site. The CONTRACTOR shall be responsible for providing all copies of approved shop drawings necessary for the construction operations.

H. the CONTRACTOR shall keep adequate records of submittal and approvals so that an accurate up-to-date record file is maintained at the job site at all times.

I. No portion of the work requiring submission of a shop drawing, product data or sample shall be commenced until the submittal has been approved by the Architect. All such portions of the work shall be in accordance with approved submittals.

### 3.1.2 SURETY BONDS

With the execution and delivery of the contract, the CONTRACTOR shall furnish and file with the OWNER in the amounts herein required, the surety bonds specified hereunder. Without exception, the OWNER'S bond forms, attached hereto as Section 00610 must be used, and exclusive venue for any lawsuit in connection with such bonds shall be specified as the county in which the OWNER'S principal office is located. Such surety bonds shall be in accordance with Texas Law, including but not limited to, the provisions of Chapter 2253 of the Texas Government Code and Chapter 3503 of the Texas Insurance Code. These bonds shall automatically be increased by the amount of any change order or supplemental agreement which increases the contract price with or without notice to the surety, but in no event shall a change which reduces the contract amount reduce the penal amount of such bonds.

A. Performance Bond. A good and sufficient bond in an amount not less than 100 percent of the total amount of the Contract Price guaranteeing the full and faithful execution of the Work and performance of the Contract in accordance with the plans, specifications and Contract Documents, including any extensions thereof, for the protection of the OWNER. This bond shall provide for the repair and/or replacement of all defects due to faulty materials and workmanship that appear within a period of one year from the date of completion and acceptance of the improvement by the OWNER or such lesser or greater period as may be designated in the Contract Documents.

B. Payment Bond. A good and sufficient bond in an amount not less than 100 percent of the total amount of the Contract Price guaranteeing the full and proper protection of all payment bond beneficiaries and claimants supplying labor and material in the prosecution of the work provided for in said Contract and for the use of each claimant.

C. Maintenance Bond. A good and sufficient bond in an amount not less than ten percent (10%) of the total amount of the Contract Price guaranteeing the project against defects.

D. Sureties. No sureties shall be accepted by the OWNER who are now in default or delinquent on any bonds or who are interested in any litigation against the OWNER. All bonds shall be made on forms furnished by the OWNER and shall be executed by not less than one corporate surety authorized to do business in the State of Texas and acceptable to the OWNER. The sureties shall be listed in the most current Federal Register Treasury List. Each bond shall be executed by the CONTRACTOR and surety. Each surety shall designate an agent resident in the OWNER'S jurisdictional area acceptable to the OWNER to whom any requisite notices may be delivered and on whom service of process may be had in matters arising out of such suretyship. The OWNER reserves the right to reject any and all sureties.

E. Additional or Substitute Bonds. If at any time the OWNER is or becomes dissatisfied with any surety, then upon the performance or payment bond, the CONTRACTOR shall, within five days after notice from the OWNER to do so, substitute an acceptable bond (or bonds), or provide an additional bond, in such form and sum and signed by such other surety or sureties as may be satisfactory to the OWNER. The premiums on such bonds shall be paid by the CONTRACTOR without recourse to the OWNER. No further payments under the contract shall be deemed due or payable until the substitute or additional bonds shall have been furnished and accepted by the OWNER.

### 3.1.3 PERMITS AND FEES



The CONTRACTOR shall secure and pay for all building permits and other permits and governmental fees, licenses and inspections necessary for proper execution and completion of the Work which are normally and legally required for the construction of similar projects in the State of Texas. The CONTRACTOR will give all notices required by laws, ordinances, rules, regulations and lawful orders of authorized public authorities required for the proper and legal performance of the Work.

### 3.14 CONTRACT DOCUMENTS AT SITE

The CONTRACTOR shall keep and maintain at the Project site one record copy of the Contract Documents, including but not limited to, the Drawings, Specifications, addenda, Change Orders, submittals, Product Data, Samples and other modifications, in good order and marked to show the current construction of the Project. These documents shall be available to the OWNER or Architect to review at any time and shall be submitted to the OWNER upon completion of the Project, along with a complete set of as built drawings.

## 3.2 CONTRACTOR'S RESPONSIBILITIES

### 3.2.1 PERFORMANCE OF THE WORK

In addition to those matters elsewhere expressly made the responsibility of the CONTRACTOR, the CONTRACTOR shall have the full and direct responsibility for the performance and completion of the Work under this Contract and for any act or neglect of the CONTRACTOR, his agents, employees or subcontractors. He shall bear all losses, if any, resulting on account of the amount and character of the Work, or because the conditions under which the work must be done are different from what were estimated or anticipated by him, or because of weather, floods, elements or other causes.

### 3.2.2 MEANS AND METHODS OF CONSTRUCTION

Unless otherwise expressly provided in the contract drawings, specifications or bulletins, the means and methods of construction shall be such as the CONTRACTOR may choose; subject, however, to the OWNER'S right to prohibit means and methods proposed by the CONTRACTOR which in the OWNER'S judgment:

- A. shall constitute a hazard to the Work, or to persons or property, or shall violate express requirements of applicable laws or ordinances; or
- B. shall cause unnecessary or unreasonable inconvenience to the public; or
- C. shall not produce finished work in accordance with the requirements of the Contract Documents; or

D. shall not assure the Work to be completed within the time allowed by the contract.

The OWNER'S approval of the CONTRACTOR'S means or methods of construction, or the OWNER'S failure to exercise his right to prohibit such means or methods, shall not relieve the CONTRACTOR of his responsibility for the Work or of his obligation to accomplish the result intended by the Contract Documents; nor shall the exercise or non-exercise of such rights to prohibit create a cause of action for damages or provide a basis for any claim by the CONTRACTOR against the OWNER. The CONTRACTOR shall be sole responsible for, the construction means and methods, techniques, sequences, procedures, and for the safety precautions and programs in connection with the Work or the Project.

If the Contract Documents specify any means, methods, techniques, sequences or procedures, the CONTRACTOR shall evaluate said specifications and determine that they are safe for the proper prosecution of the Work. The CONTRACTOR shall be sole responsible for the job site safety of such means, methods, techniques, sequences or procedures. If the CONTRACTOR determines the specified means, methods, techniques, sequences or procedures may not be safe, the CONTRACTOR shall immediately notify the OWNER and Architect and shall not proceed without further instructions.

### 3.2.3 CONSTRUCTION SCHEDULE

The CONTRACTOR, immediately after being awarded the contract, shall prepare and submit for the OWNER or Architect's information an estimated progress schedule for the work. The progress schedule shall be related to the entire Project to the extent required by the Contract Documents and shall provide for expeditious and reasonable execution of the work, not to exceed the time limits for completion provided in the Contract Documents. The progress schedule shall be updated as the Work proceeds or the schedule changes and immediately upon request by the OWNER. The CONTRACTOR shall also prepare a schedule of submittals that allows for a reasonable time for the OWNER or Architect to review the submittals so as not to delay the Project.

### 3.2.4 TIME OF PERFORMANCE OF THE WORK

The CONTRACTOR shall begin the work to be performed under this Contract not later than 10 days from the date specified in the purchase or work order and shall conduct the work in such a manner and with sufficient equipment, material and labor as is necessary to insure its completion within the working time. It is the intent of this specification to provide a continuous construction operation without delay except as occasioned by unforeseeable causes beyond the control and without the fault or negligence of the CONTRACTOR, and it shall be the CONTRACTOR's responsibility to execute the work in the most expeditious manner.

Work shall be done only during the regular and commonly accepted and prescribed working hours. No work shall be done on nights, Sundays or regular holidays unless permission is given by the OWNER

Time is of the Essence for the performance of the Work by the CONTRACTOR. CONTRACTOR agrees that the time allotted for the performance of the Work is reasonable.

### 3.2.5 PERFORMANCE OF EXTRA OR DISPUTED WORK

While the CONTRACTOR or his subcontractor is performing Extra Work in accordance with the OWNER'S written order, the cost of which is to be determined on a time and material basis, or is performing disputed work or complying with a determination or order under protest, the CONTRACTOR shall, on the Monday following the performance of the work, furnish the OWNER'S representative at the site with three copies of verified statements showing:

- A. the name and number of each workman employed on such extra work or engaged in complying with such determination or order, the character of extra work each is doing and the wages paid to him, including the rate and amount of payroll taxes, contributions for insurance, and federal social security; and
- B. the nature, cost and quantity of any materials, plant equipment or construction equipment furnished or used in connection with the performance of such extra work or in complying with such determination or order, and from who purchased or rented.

The CONTRACTOR and his subcontractors, when required by the OWNER, must also produce for inspection and audit by designated OWNER representatives for a minimum period of three (3) years following final payment or termination of contract any and all of his books, vouchers, records, daily job diaries and reports, canceled checks, etc. showing the nature and quantity of labor, materials and equipment actually used in the performance of the extra work; the amounts expended therefore; and the costs incurred for insurance premiums and other items of expense directly chargeable to such extra work. The CONTRACTOR must permit the OWNER'S representatives to make extracts therefrom or copies thereof as may be desired.

Failure of the CONTRACTOR to comply strictly with the requirements of this section shall constitute a waiver of any claim for extra compensation on account of the performance of such extra work.

## 3.3 QUALITY OF WORK

### 3.3.1 INSPECTION AND TESTS

The CONTRACTOR shall furnish the OWNER with every reasonable accommodation and opportunity to ascertain whether or not the work performed is in accordance with the requirements and intent of the plans and specifications. Any work done or materials used without suitable inspection by the OWNER may be ordered removed and replaced at the CONTRACTOR'S expense. The CONTRACTOR shall not be relieved from his obligations to perform the Work in accordance with the Contract Documents either by the activities or duties of the OWNER in his administration of the contract, or by inspections, tests or approvals required or performed by persons other than the CONTRACTOR.

Unless otherwise provided, the CONTRACTOR shall make arrangements for all tests, inspections and approvals with an independent testing laboratory or entity required by the Contract Documents or by laws, ordinances, rules, regulations or orders of public authorities having jurisdiction over the Work or items to be tested, inspected or approved. If additional testing or inspection is required they shall be performed at the CONTRACTOR'S expense.

### 3.3.2 REMOVAL OF DEFECTIVE AND UNAUTHORIZED WORK

All work which has been rejected or condemned shall be repaired, or if it cannot be repaired satisfactorily, it shall be removed and replaced at the CONTRACTOR'S expense. Defective materials shall be immediately removed from the site of the work. Work done without line and grade having been given, work done beyond the lines or not in conformity with the grades shown on the plans or as given, save as herein provided, work done without written authority and prior agreement in writing as to process, shall be done at the CONTRACTOR'S risk and shall be considered unauthorized and at the option of the OWNER may be ordered removed at the CONTRACTOR'S expense.

Upon failure of the CONTRACTOR to repair satisfactorily or to remove and replace, if so directed, rejected, unauthorized or condemned work or materials immediately after receiving notice from the OWNER, the OWNER shall, after giving written notice to the CONTRACTOR, have the authority to cause defective work to be remedied or removed and replaced, or to cause unauthorized work to be removed and to deduct the cost thereof from any monies due or to become due the CONTRACTOR. Alternatively, the OWNER may, at its option, declare the CONTRACTOR in default.

### 3.3.3 WORKING AREA; COORDINATION WITH OTHER CONTRACTORS; FINAL CLEANUP

The CONTRACTOR shall confine his equipment, storage of materials and construction operations to the area shown on the contract drawings or stated in the specifications, prescribed by ordinance, laws, or permits or as may be directed by

the OWNER, and shall not unreasonably encumber the site or public right-of-way with his construction equipment, plant or materials.

Such area shall not be deemed for the exclusive use of the CONTRACTOR. Other contractors of the OWNER may enter upon and use such portions of the area and for such items as determined by the OWNER are necessary for all purposes required by their contracts. The CONTRACTOR shall give to such other contractors all reasonable facilities and assistance to the end that the work on this and other contracts shall not be unduly or unreasonably delayed. Any additional areas desired by the CONTRACTOR for his use shall be provided by him at his own cost and expense.

The CONTRACTOR is responsible for cutting, fitting or patching any parts of the Work where such work is necessary to make the Work complete, for parts to fit together, or for any damage to the Work prior to Final Acceptance.

The CONTRACTOR shall keep the Project and the surrounding area clean and free from the accumulation of waste materials or trash. Upon completion of the work and before final acceptance and final payment shall be made, the CONTRACTOR shall completely clean and remove from the site of the work surplus and discarded materials, temporary structures and debris of every kind. He shall leave the site of the work in a neat and orderly condition equal to that which originally existed, or as called for in the Contract Documents. Surplus and waste materials removed from the site of the work shall be disposed of at locations satisfactory to the OWNER, and at the CONTRACTOR'S sole cost.

### 3.4 LEGAL RESPONSIBILITIES

#### 3.4.1. PATENTS AND COPYRIGHTS

The CONTRACTOR shall pay all royalties and license fees and shall provide, by suitable legal agreement with the patentee or owner, for the use of any design, device, material or process covered by letters, patent or any copyright. The CONTRACTOR shall indemnify, defend, hold and save the OWNER and its officers, employees and agents harmless from all liability and claims for infringement of any patent or copyright.

In the event that any claims, suit or action at law or in equity of any kind whatsoever is brought against the OWNER, or its officers, employees or agents involving any such patents, copyrights or license rights, then the OWNER shall have the right to and may retain from any money due or to become due to the CONTRACTOR such sum deemed necessary by the OWNER for its protection until such claim or suit shall have been settled and satisfactory evidence to that effect shall have been furnished the OWNER.

#### 3.4.2 INDEMNIFICATION

To the fullest extent permitted by law, the CONTRACTOR and his sureties shall indemnify, defend and hold harmless the OWNER and all of its, past, present and future, officers, agents and employees from all suits, cause of action, claims, liabilities, losses, fines, penalties, liens, demands, obligations, actions, proceedings, of any kind, character, name and description brought or arising, on account of any injuries or damages received or sustained by any person, destruction or damage to any property on account of, in whole or part, the operations of the CONTRACTOR, his agents, employees or subcontractors; or on account of any negligent act or fault of the CONTRACTOR, his agents, employees or subcontractors in the execution of said Contract; failing to comply with any law, ordinance, regulation, rule or order of any governmental or regulatory body including those dealing with health, safety, welfare or the environment; on account of the failure of the CONTRACTOR to provide the necessary barricades, warning lights or signs; and shall be required to pay any judgment, with cost, which may be obtained against the OWNER growing out of such injury or damage. In no event shall OWNER be liable to CONTRACTOR for indirect or consequential damages or loss of income or profit irrespective of the cause, fault or reason for same. CONTRACTOR'S duty to indemnify herein shall not be limited by any limitation on the type or amount of damages payable by or for CONTRACTOR or any Subcontractor under workman's compensation acts, disability benefit acts or any other employee benefit acts.

In addition, the CONTRACTOR likewise covenants and agrees to, and does hereby, indemnify and hold harmless the OWNER from and against any and all injuries, loss or damages to property of the OWNER during the performance of any of the terms and conditions of this Contract, arising out of or in connection with or resulting from, in whole or in part, any and all alleged acts or omissions of officers, agents, servants, employees, contractors, subcontractors, licenses or invitees of the CONTRACTOR.

The rights and responsibilities provided in this indemnification provision shall survive the termination or completion of this Contract.

### 3.5 SUPERVISION AND CONSTRUCTION PROCEDURES

#### 3.5.1. SUPERVISION BY CONTRACTOR

The status of the CONTRACTOR is that of an independent CONTRACTOR under Texas law and the work under this Contract shall be under the direct charge and superintendence of the CONTRACTOR. Except where the CONTRACTOR is an individual and gives his personal superintendence to the work, the CONTRACTOR shall provide a competent superintendent or general foreman on the work site at all times during progress with full authority to act for the CONTRACTOR. The CONTRACTOR shall also provide an adequate staff for the coordination and expediting of the Work.

The superintendent and staff shall be satisfactory to the OWNER. The superintendent or general foreman shall not be changed during this Contract except with the written consent of the OWNER or unless the superintendent or general foreman proves unsatisfactory to the CONTRACTOR and ceases to be in his employ.

If the superintendent should be or become unsatisfactory to the OWNER, he shall be replaced by the CONTRACTOR upon written direction of the OWNER, and in such event, the CONTRACTOR shall not be entitled to file a claim for any additional working time or money from the OWNER.

### 3.5.2 EMPLOYEES

The CONTRACTOR shall employ only competent, efficient workmen and shall not use on the work any unfit person or one not skilled in the work assigned to him and shall at all times maintain good order among its employees. Whenever the OWNER shall inform the CONTRACTOR in writing that, in his opinion, any employee is unfit, unskilled, disobedient, or is disrupting the orderly progress of the work, such employee shall be removed from the work and shall not again be employed on it. Under urgent circumstances, the OWNER may orally require immediate removal of an employee for cause, to be followed by written confirmation.

The CONTRACTOR shall supervise and direct all the work, using his best skill and attention. He shall be solely responsible for all construction means, methods, techniques, sequences, procedures and safety procedures and for coordinating all portions of the Work under the Contract. The CONTRACTOR shall be responsible to the OWNER for the acts and omissions of his employees, subcontractors and their agents, employees and subcontractors performing any of the work under a contract with the CONTRACTOR.

### 3.5.3 LABOR AND MATERIALS

Unless otherwise provided in the Contract Documents, the CONTRACTOR shall provide and pay for all labor, materials, equipment, tools, construction equipment and machinery, water, heat, utilities, transportation and other facilities and services necessary for the proper execution and completion of the work, whether temporary or permanent and whether or not incorporated or to be incorporated into the work.

The CONTRACTOR shall at all times enforce strict discipline and good order among his employees and shall not employ on the work site any unfit person or anyone not skilled in the task assigned to him.

The rate of progress shall be such that the whole work shall be performed and the premises cleaned up in accordance with the Contract within the working time established in the Contract, unless an extension of time is made in the manner hereinafter specified.

### 3.5.4 WAGE SCALE

In accordance with The Texas Government Code, Title 10, Chapter 2258, Prevailing Wage Rates, the general prevailing wage rate has been determined for this locality for the craft or type of workman needed to execute work of a similar character of the project listed herein. The Contractor shall pay the prevailing wage rate in this locality to all his/her employees and subcontractors performing work on this project, and in no event shall the Contractor pay less than the rate shown in the following schedule.

General Decision Number: TX180289 01/12/2018 TX289

Superseded General Decision Number: TX20170289

State: Texas

Construction Type: Building

County: Collin County in Texas.

**BUILDING CONSTRUCTION PROJECTS** (does not include single family homes or apartments up to and including 4 stories).

Note: Under Executive Order (EO) 13658, an hourly minimum wage of \$10.35 for calendar year 2018 applies to all contracts subject to the Davis-Bacon Act for which the contract is awarded (and any solicitation was issued) on or after January 1, 2015. If this contract is covered by the EO, the contractor must pay all workers in any classification listed on this wage determination at least \$10.35 per hour (or the applicable wage rate listed on this wage determination, if it is higher) for all hours spent performing on the contract in calendar year 2018. The EO minimum wage rate will be adjusted annually. Please note that this EO applies to the above-mentioned types of contracts entered into by the federal government that are subject to the Davis-Bacon Act itself, but it does not apply to contracts subject only to the Davis-Bacon Related Acts, including those set forth at 29 CFR 5.1(a)(2)-(60). Additional information on contractor requirements and worker protections under the EO is available at [www.dol.gov/whd/govcontracts](http://www.dol.gov/whd/govcontracts).

Modification Number    Publication Date

0            01/05/2018

1            01/12/2018

ASBE0021-011 06/01/2016

Rates            Fringes

ASBESTOS WORKER/HEAT & FROST  
INSULATOR (Duct, Pipe and

Mechanical System Insulation)....\$ 24.32            7.52

-----



BOIL0074-003 01/01/2017

	Rates	Fringes
BOILERMAKER.....	\$ 28.00	22.35

-----  
CARP1421-002 04/01/2016

	Rates	Fringes
MILLWRIGHT.....	\$ 26.60	8.65

-----  
\* ELEV0021-006 01/01/2018

	Rates	Fringes
ELEVATOR MECHANIC.....	\$ 39.97	32.645+a+b

FOOTNOTES:

A. 6% under 5 years based on regular hourly rate for all hours worked. 8% over 5 years based on regular hourly rate for all hours worked.

B. New Year's Day, Memorial Day, Independence Day, Labor Day, Thanksgiving Day, the Friday after Thanksgiving Day, Christmas Day, and Veterans Day.

-----  
ENGI0178-005 06/01/2014

	Rates	Fringes
POWER EQUIPMENT OPERATOR		
(1) Tower Crane.....	\$ 29.00	10.60
(2) Cranes with Pile Driving or Caisson Attachment and Hydraulic Crane 60 tons and above.....	\$ 28.75	10.60
(3) Hydraulic cranes 59 Tons and under.....	\$ 27.50	10.60

-----  
IRON0263-005 06/01/2017

	Rates	Fringes
IRONWORKER (ORNAMENTAL AND STRUCTURAL).....	\$ 23.25	7.32

-----  
PLUM0100-005 11/01/2017

	Rates	Fringes
HVAC MECHANIC (HVAC Unit Installation Only).....	\$ 30.84	11.51
PIPEFITTER (Excludes HVAC Pipe Installation).....	\$ 30.84	11.51

-----  
SUTX2014-015 07/21/2014

	Rates	Fringes
BRICKLAYER.....	\$ 21.06	0.00
CARPENTER, Excludes Drywall Hanging, Form Work, and Metal Stud Installation.....	\$ 15.78	0.00
CAULKER.....	\$ 15.16	0.00
CEMENT MASON/CONCRETE FINISHER...	\$ 13.04	0.00
DRYWALL HANGER AND METAL STUD INSTALLER.....	\$ 13.00	0.00
ELECTRICIAN (Alarm Installation Only).....	\$ 20.93	3.86
ELECTRICIAN (Communication Technician Only).....	\$ 15.35	1.39
ELECTRICIAN (Low Voltage Wiring Only).....	\$ 17.04	1.39
ELECTRICIAN, Excludes Low Voltage Wiring and Installation of Alarms/Sound and Communication Systems.....	\$ 20.01	2.69
FORM WORKER.....	\$ 11.89	0.00
GLAZIER.....	\$ 16.46	3.94
HIGHWAY/PARKING LOT STRIPING: Operator (Striping Machine).....	\$ 10.04	2.31

INSTALLER - SIDING (METAL/ALUMINUM/VINYL).....	\$ 14.74	0.00
INSTALLER - SIGN.....	\$ 15.50	0.00
INSULATOR - BATT.....	\$ 13.00	0.00
IRONWORKER, REINFORCING.....	\$ 12.29	0.00
LABORER: Common or General.....	\$ 10.52	0.00
LABORER: Mason Tender - Brick...	\$ 10.54	0.00
LABORER: Mason Tender - Cement/Concrete.....	\$ 10.93	0.00
LABORER: Pipelayer.....	\$ 13.00	0.35
LABORER: Plaster Tender.....	\$ 12.22	0.00
LABORER: Roof Tearoff.....	\$ 11.28	0.00
LABORER: Landscape and Irrigation.....	\$ 10.55	0.00
LATHER.....	\$ 16.00	0.00
OPERATOR: Backhoe/Excavator/Trackhoe.....	\$ 12.83	0.00
OPERATOR: Bobcat/Skid Steer/Skid Loader.....	\$ 13.93	0.00
OPERATOR: Bulldozer.....	\$ 18.29	1.31
OPERATOR: Drill.....	\$ 15.69	0.50
OPERATOR: Forklift.....	\$ 13.21	0.81
OPERATOR: Grader/Blade.....	\$ 13.03	0.00
OPERATOR: Loader.....	\$ 13.46	0.85
OPERATOR: Mechanic.....	\$ 17.52	3.33
OPERATOR: Paver (Asphalt,		

Aggregate, and Concrete).....\$ 18.44	0.00
OPERATOR: Roller.....\$ 15.04	0.00
PAINTER (Brush, Roller and Spray), Excludes Drywall Finishing/Taping.....\$ 13.35	5.10
PAINTER: Drywall Finishing/Taping Only.....\$ 14.24	3.83
PIPEFITTER (HVAC Pipe Installation Only).....\$ 20.45	4.00
PLASTERER.....\$ 16.58	0.00
PLUMBER, Excludes HVAC Pipe Installation.....\$ 22.46	4.06
ROOFER.....\$ 17.19	0.00
SHEET METAL WORKER (HVAC Duct Installation Only).....\$ 21.13	4.79
SHEET METAL WORKER, Excludes HVAC Duct Installation.....\$ 24.88	5.97
SPRINKLER FITTER (Fire Sprinklers).....\$ 37.50	0.00
TILE FINISHER.....\$ 11.22	0.00
TILE SETTER.....\$ 14.25	0.00
TRUCK DRIVER: 1/Single Axle Truck.....\$ 16.00	0.81
TRUCK DRIVER: Dump Truck.....\$ 12.39	1.18
TRUCK DRIVER: Flatbed Truck.....\$ 19.65	8.57
TRUCK DRIVER: Semi-Trailer Truck.....\$ 12.50	0.00
TRUCK DRIVER: Water Truck.....\$ 12.00	4.11
-----	

WELDERS - Receive rate prescribed for craft performing operation to which welding is incidental.

=====

Note: Executive Order (EO) 13706, Establishing Paid Sick Leave for Federal Contractors applies to all contracts subject to the Davis-Bacon Act for which the contract is awarded (and any solicitation was issued) on or after January 1, 2017. If this contract is covered by the EO, the contractor must provide employees with 1 hour of paid sick leave for every 30 hours they work, up to 56 hours of paid sick leave each year. Employees must be permitted to use paid sick leave for their own illness, injury or other health-related needs, including preventive care; to assist a family member (or person who is like family to the employee) who is ill, injured, or has other health-related needs, including preventive care; or for reasons resulting from, or to assist a family member (or person who is like family to the employee) who is a victim of, domestic violence, sexual assault, or stalking. Additional information on contractor requirements and worker protections under the EO is available at [www.dol.gov/whd/govcontracts](http://www.dol.gov/whd/govcontracts).

Unlisted classifications needed for work not included within the scope of the classifications listed may be added after award only as provided in the labor standards contract clauses (29CFR 5.5 (a) (1) (ii)).

-----

The body of each wage determination lists the classification and wage rates that have been found to be prevailing for the cited type(s) of construction in the area covered by the wage determination. The classifications are listed in alphabetical order of "identifiers" that indicate whether the particular rate is a union rate (current union negotiated rate for local), a survey rate (weighted average rate) or a union average rate (weighted union average rate).

#### Union Rate Identifiers

A four letter classification abbreviation identifier enclosed in dotted lines beginning with characters other than "SU" or "UAVG" denotes that the union classification and rate were prevailing for that classification in the survey. Example: PLUM0198-005 07/01/2014. PLUM is an abbreviation identifier of the union which prevailed in the survey for this classification, which in this example would be Plumbers. 0198 indicates the local union number or district council number where applicable, i.e., Plumbers Local 0198. The next number, 005 in the example, is an internal number used in processing the wage determination. 07/01/2014 is the effective date of the most current negotiated rate, which in this example is July 1, 2014.

Union prevailing wage rates are updated to reflect all rate changes in the collective bargaining agreement (CBA) governing this classification and rate.

#### Survey Rate Identifiers

Classifications listed under the "SU" identifier indicate that no one rate prevailed for this classification in the survey and the published rate is derived by computing a weighted average rate based on all the rates reported in the survey for that classification. As this weighted average rate includes all rates reported in the survey, it may include both union and non-union rates. Example: SULA2012-007 5/13/2014. SU indicates the rates are survey rates based on a weighted average calculation of rates and are not majority rates. LA indicates the State of Louisiana. 2012 is the year of survey on which these classifications and rates are based. The next number, 007 in the example, is an internal number used in producing the wage determination. 5/13/2014 indicates the survey completion date for the classifications and rates under that identifier.

Survey wage rates are not updated and remain in effect until a new survey is conducted.

#### Union Average Rate Identifiers

Classification(s) listed under the UAVG identifier indicate that no single majority rate prevailed for those classifications; however, 100% of the data reported for the classifications was union data. EXAMPLE: UAVG-OH-0010 08/29/2014. UAVG indicates that the rate is a weighted union average rate. OH indicates the state. The next number, 0010 in the example, is an internal number used in producing the wage determination. 08/29/2014 indicates the survey completion date for the classifications and rates under that identifier.

A UAVG rate will be updated once a year, usually in January of each year, to reflect a weighted average of the current negotiated/CBA rate of the union locals from which the rate is based.

---

### WAGE DETERMINATION APPEALS PROCESS

1.) Has there been an initial decision in the matter? This can be:

- \* an existing published wage determination
- \* a survey underlying a wage determination
- \* a Wage and Hour Division letter setting forth a position on a wage determination matter
- \* a conformance (additional classification and rate) ruling

On survey related matters, initial contact, including requests for summaries of surveys, should be with the Wage and Hour Regional Office for the area in which the survey was conducted because those Regional Offices have responsibility for the Davis-Bacon survey program. If the response from this initial contact is not satisfactory, then the process described in 2.) and 3.) should be followed.

With regard to any other matter not yet ripe for the formal process described here, initial contact should be with the Branch of Construction Wage Determinations. Write to:

Branch of Construction Wage Determinations  
Wage and Hour Division  
U.S. Department of Labor  
200 Constitution Avenue, N.W.  
Washington, DC 20210

2.) If the answer to the question in 1.) is yes, then an interested party (those affected by the action) can request review and reconsideration from the Wage and Hour Administrator (See 29 CFR Part 1.8 and 29 CFR Part 7). Write to:

Wage and Hour Administrator  
U.S. Department of Labor  
200 Constitution Avenue, N.W.  
Washington, DC 20210

The request should be accompanied by a full statement of the interested party's position and by any information (wage payment data, project description, area practice material, etc.) that the requestor considers relevant to the issue.

3.) If the decision of the Administrator is not favorable, an interested party may appeal directly to the Administrative Review Board (formerly the Wage Appeals Board). Write to:

Administrative Review Board  
U.S. Department of Labor  
200 Constitution Avenue, N.W.  
Washington, DC 20210

4.) All decisions by the Administrative Review Board are final.

=====  
END OF GENERAL DECISION

B. Except for work on legal holidays, the "General Prevailing Rate of Per Diem Wage" for the various crafts or type of workers or mechanics is the product of (a) the number of hours worked per day, except for overtime hours, times (b) the above respective rate per hour.

For legal holidays, the "General Prevailing Rate of Per Diem Wage" for the various crafts or type of workers or mechanics is the product of (a) one and one-half times the above respective rate per hour, times (b) the number of hours worked on the legal holiday.

For overtime work, the "General Prevailing Rate of Per Diem Wage" for the various crafts or type of workers or mechanics is the product of (a) one and one-half

times the above respective rate per hour, times (b) the number of hours worked on overtime.

Under the provisions of Texas Government Code, Title 10, Chapter 2258, Prevailing Wage Rates, the contractor or subcontractor of the contractor shall forfeit as a penalty to the entity on whose behalf the contract is made or awarded, sixty dollars (\$60.00) for each calendar day, or portion thereof, that the worker is paid less than the wage rates stipulated in the contract.

If the construction project involves the expenditure of Federal funds in excess of \$2,000, the minimum wages to be paid various classes of laborers and mechanics will be based upon the wages that will be determined by the Secretary of Labor to be prevailing for the corresponding classes of laborers and mechanics employed on the project of a character similar to the Contract Work.

3.5.5 Contractors doing business with OWNER agree to comply with Federal Executive Order 13465 E-Verify. It is OWNER'S intention and duty to comply and support the Immigration and Nationality Act (INA) which includes provisions addressing employment eligibility, employment verification and non-discrimination. According to the INA, contractors/employers may hire only persons who may legally work in the United States. Subsequently, contractors and subcontractors doing business with OWNER must confirm their enrollment in the E-Verify system which verifies employment eligibility through completion and checking of I-9 forms. OWNER reserves the right to audit contractor's process to verify enrollment compliance.

### 3.5.6 COMPLIANCE WITH LAWS

The CONTRACTOR shall fully comply with all local, state and federal laws, including all codes, ordinances and regulations applicable to this Contract and the Work to be done thereunder, which exist or which may be enacted later by governmental bodies having jurisdiction or authority for such enactment.

All work required under this Contract is intended to comply with all requirements of law, regulation, permit or license. If the CONTRACTOR finds that there is a variance, he shall immediately report this to the OWNER for resolution.

#### 3.5.6.1 EQUAL EMPLOYMENT OPPORTUNITY

The CONTRACTOR shall comply with all local, state and federal employment and discrimination laws and shall not discriminate against any employee or applicant for employment because of race, color, religion, sex, age, national origin or any other class protected by law.

### 3.5.7 RAILWAY CROSSINGS

Where the Work encroaches upon any right-of-way of any railway, the OWNER shall secure the necessary easement for the work. Where railway tracks are to be crossed, the CONTRACTOR shall observe all the regulations and instructions of



the railway company as to methods of doing the work or precautions for safety of property and the public. All negotiations with the railway company, except for right-of-way, shall be made by the CONTRACTOR. The railway company shall be notified by the CONTRACTOR not less than five days prior to commencing the work. The CONTRACTOR shall not be paid separate compensation for such railway crossing but shall receive only the compensation as set out in the proposal.

### 3.5.8 OTHER CONTRACTORS; OBLIGATION TO COOPERATE

The OWNER reserves the right to perform construction on the Project with its own forces or may award other contracts for additional work on this Project, and the CONTRACTOR shall fully cooperate with such other contractors and shall coordinate and fit his work to be done hereunder to such additional work as may be contracted by the OWNER. The CONTRACTOR shall not commit or permit any act which shall interfere with the performance of work by any other contractor.

Upon receiving written notice from the CONTRACTOR that the OWNER or another contractor is failing to coordinate his work with the Work under this Contract as directed by the OWNER, the OWNER shall promptly investigate the charge and take such necessary action as the situation may require. However, the OWNER shall not be liable to the CONTRACTOR for damages suffered by the CONTRACTOR due to the fault or negligence of another contractor or through failure of another contractor to carry out the directions of the OWNER. Should any interference occur between contractors, the Architect may furnish the CONTRACTOR with written instructions designating priority of effort, whereupon the CONTRACTOR shall immediately comply with such direction. In such event, the CONTRACTOR shall be entitled to an extension of working time only for unavoidable delays verified by the Architect; however, no increase in the Contract Price shall be due the CONTRACTOR.

### 3.5.9 SUBCONTRACTS

The CONTRACTOR shall not make any subcontract for performing any portion of the Work included in the contract without written notice to the OWNER. This contract having been made pursuant to the bid submitted by the CONTRACTOR and in reliance with the CONTRACTOR'S personal qualifications and responsibility, the OWNER reserves the right to withhold approval of any subcontractor which the OWNER may deem would not be in the OWNER'S best interest.

The CONTRACTOR shall, as soon as practicable after signing the Contract, submit a separate written notice to the OWNER identifying each proposed subcontractor. Upon request of the OWNER, the CONTRACTOR shall promptly furnish additional information tending to establish that any proposed subcontractor has the necessary facilities, skill, integrity, past experience and financial resources to perform the work in accordance with the terms and conditions of this Contract.

If the OWNER determines that any proposed subcontractor is unacceptable, he shall so notify the CONTRACTOR, who may thereupon submit another proposed subcontractor unless the CONTRACTOR decides to do the work himself. Disapproval by the OWNER of any proposed subcontractor shall not provide a basis for any claim by the CONTRACTOR.

If an approved subcontractor fails to properly perform the work undertaken, he shall be removed from the job upon request of the OWNER, following notification to the CONTRACTOR in writing of the request for removal and the reasons therefore.

Each subcontract entered into shall provide that the provisions of this Contract shall apply to such subcontractor and his officers and employees in all respects as if he and they were employees of the CONTRACTOR. The OWNER'S decision not to disapprove of any subcontract shall not relieve the CONTRACTOR of any of his responsibilities, duties and liabilities hereunder. The CONTRACTOR shall be solely responsible for the acts, omissions, negligence or defaults of his subcontractors and of such subcontractor's officers, agents and employees, each of whom shall, for this purpose, be deemed to be the agent or employee of the CONTRACTOR to the extent of his subcontract.

The CONTRACTOR agrees to bind each subcontractor and each subcontractor agrees to be bound by the terms of the Contract Documents insofar as applicable to his work. The CONTRACTOR and each subcontractor jointly and severally agree that nothing in the Contract Documents or otherwise shall create or be deemed to create any rights in favor of a subcontractor against the OWNER; nor shall be deemed or construed to impose upon the OWNER any obligation, liability or duty to a subcontractor; or to create any contractual relation whatsoever between a subcontractor and the OWNER.

The provisions contained herein shall likewise apply to any sub-subcontracts.

### 3.6 PROTECTION OF WORK AND OF PERSONS AND PROPERTY

#### 3.6.1 PROTECTION OF WORK

During performance and up to date of final acceptance, the CONTRACTOR shall be under the absolute obligation to protect the finished work against any damage, loss or injury. In the event of such damage, loss or injury, the CONTRACTOR shall promptly replace or repair such work, whichever the OWNER shall determine to be preferable. The obligation to deliver finished work in strict accordance with the Contract prior to final acceptance shall be absolute and shall not be affected by the OWNER'S approval of or failure to prohibit means and methods of construction used by the CONTRACTOR. All risk of loss or damage to the work shall be borne solely by the CONTRACTOR until final completion and acceptance of all work by

the OWNER, as evidenced by the OWNER'S issuance of a certificate of acceptance.

### 3.6.2 PROTECTION OF PERSONS AND PROPERTY

The CONTRACTOR shall have the responsibility to provide and maintain all warning devices and take all precautionary measures required by law or otherwise to protect persons and property while said persons or property are approaching, leaving or within the work site or any area adjacent to said work site. No separate compensation shall be paid to the CONTRACTOR for the installation or maintenance of any warning devices, barricades, lights, signs or any other precautionary measures required by law or otherwise for the protection of persons or property.

The CONTRACTOR shall assume all duties owed by the OWNER to the general public in connection with the general public's immediate approach to and travel through the work site and the area adjacent to said work site.

Where the work is carried on in or adjacent to any street, alley, sidewalk, public right-of-way or public place, the CONTRACTOR shall at his own cost and expense provide such flagmen and watchmen and furnish, erect and maintain such warning devices, barricades, lights, signs and other precautionary measures for the protection of persons or property as may be prudent or necessary, or as are required by law. The CONTRACTOR'S responsibility for providing and maintaining flagmen, watchmen, warning devices, barricades, signs and lights and other precautionary measures shall not cease until the project shall have been completed and accepted by the OWNER, and shall cease when the certificate of acceptance is issued by the OWNER pursuant to the Contract Documents.

If the OWNER discovers that the CONTRACTOR has failed to comply with the applicable federal and state law (by failing to furnish the necessary flagmen, warning devices, barricades, lights, signs or other precautionary measures for the protection of persons or property), the OWNER may order the CONTRACTOR to take such additional precautionary measures as required by law to be taken to protect persons and property.

In addition, the CONTRACTOR shall be held responsible for all damages to the work and other public or private property due to the failure of warning devices, barricades, signs, lights or other precautionary measures in protecting said property; and whenever evidence is found of such damage, the OWNER may order the damaged portion immediately removed and replaced by and at the cost and expense of the CONTRACTOR.

### 3.6.3 SAFETY; TRENCH SAFETY; UNDERGROUND UTILITY SAFETY; PUBLIC CONVENIENCE AND SAFETY;

The CONTRACTOR shall be responsible for complying with state laws and federal regulations relating to safety, trench safety, and underground utility safety, including those which may be enacted during the performance under this Contract. The CONTRACTOR shall comply with the provisions of the The Standard Specifications and Standard Drawings from the Public Works Construction Standards-North Central Texas Council of Governments, 2004 edition and all subsequent addendums and the Instructions to Bidders regarding trench safety, public convenience and safety, and sanitary provisions. The CONTRACTOR shall be solely responsible for, the construction means and methods, techniques, sequences, or procedures, or for the safety precautions and programs in connection with the Work and the Project.

### 3.7 MATERIALS AND WORKMANSHIP; WARRANTIES AND GUARANTEES

Unless otherwise expressly provided in the contract drawings or specifications, the work shall be performed in accordance with the best modern practice with materials and workmanship of the highest quality and suitable for their purpose. The OWNER shall judge and determine the CONTRACTOR'S compliance with these requirements.

#### 3.7.1 MATERIALS AND EQUIPMENT

The CONTRACTOR shall be free to secure the approved materials, equipment and articles from sources of his own selection. However, if the OWNER finds that the work shall be delayed or adversely affected in any way because a selected source of supply cannot furnish a uniform product in sufficient quantity and at the time required and a suitable source does exist, or the product is not suitable for the Work, the OWNER shall have the right to require the original source of supply changed by the CONTRACTOR. The CONTRACTOR shall have no claim for extra cost or damage because of this requirement.

The CONTRACTOR warrants to the OWNER that all materials and equipment furnished under this contract shall be new unless otherwise specified in the Contract Documents and that same shall be of good quality and workmanship, free from faults and defects and in conformance with the Contract Documents. All materials and equipment not conforming to these requirements, including substitutions not properly approved and authorized, may be considered defective and shall be promptly repaired or replaced by the CONTRACTOR at the CONTRACTOR'S sole cost upon demand of the OWNER. If required by the OWNER, the CONTRACTOR shall furnish satisfactory evidence as to the kind and quality of materials and equipment.

##### 3.7.1.1 "OR EQUAL" CLAUSE

A. Whenever a material or article required is specified or shown on the plans, by using the name of a proprietary product or of a particular manufacturer or vendor, any material or article which the Architect determines shall perform adequately the duties imposed by

the general design or which the Architect deems to be of similar appearance (in cases where appearance is of importance) shall be considered equal and satisfactory, provided the material or article so proposed is of equal substance and function. Authorization for any substitution of materials or articles must be obtained by the CONTRACTOR from the Architect before proceeding with such substitution.

B. Should an authorized substitution require redesign of a portion of the work or alterations to the plans or specifications in order for the materials or articles which are to be substituted to properly fit or in other ways to be satisfactory, the Architect shall accomplish such redesigns and alterations. The CONTRACTOR shall bear all reasonable costs associated with redesign and alteration efforts performed by the Architect.

### 3.7.2 WORKMANSHIP

The CONTRACTOR shall promptly correct or replace all work rejected by the OWNER as defective or as failing to conform to the Contract Documents whether observed before or after substantial completion and whether or not fabricated, installed or completed. The CONTRACTOR shall bear all costs of correcting such rejected work, including costs incurred for additional services made necessary thereby.

## 3.8 WARRANTIES

### 3.8.1 SPECIAL WARRANTY

If within one year after final acceptance of the work by the OWNER, as evidenced by the final certificate of acceptance or within such longer or shorter period of time as may be prescribed by law or by the terms of any other applicable special warranty on designated equipment or portions of work as required by the Contract Documents, any of the work is found to be defective or not in accordance with the Contract Documents, the CONTRACTOR shall correct it promptly after receipt of a written notice from the OWNER to do so. This obligation shall survive termination or completion of the Contract. The OWNER shall give such notice promptly after discovery of the condition.

The CONTRACTOR shall remove from the site all portions of the work which are defective or nonconforming and which have not been corrected unless removal is waived in writing by the OWNER.

### 3.8.2 SUBCONTRACTORS' AND MANUFACTURERS' WARRANTIES

All subcontractors', manufacturers' and suppliers' warranties and guarantees, express or implied, respecting any part of the work and any materials used therein,

shall be obtained and enforced by the CONTRACTOR for the benefit of the OWNER without the necessity of separate transfer or assignment thereof.

### 3.8.3 CORRECTED WORK WARRANTY

Any work repaired or replaced, pursuant to this section, shall be subject to the provisions of this section to the same extent as work originally performed.

### 3.8.4 RIGHTS AND REMEDIES

The rights and remedies of the OWNER provided in this section are in addition to, and do not limit, any rights or remedies afforded to the OWNER by law or any other provision of the Contract Documents, or in any way limit the OWNER'S right to recovery of damage due to default under the Contract. No action or inaction by the OWNER shall constitute a waiver of a right or duty afforded it under the Contract.

## IV. INSURANCE

### 4.1 CONTRACTOR'S INSURANCE

Before commencing work, the CONTRACTOR and each subcontractor shall be required, at its own expense, to furnish the Collin County Purchasing Agent with certified copies of all insurance certificate(s) required by Texas Law, and the coverages required herein, indicating the coverage is to remain in force throughout the term of this Contract. Without limiting any of the other obligations or liabilities of the CONTRACTOR, during the term of the Contract the CONTRACTOR and each subcontractor at their own expense shall purchase and maintain the herein stipulated minimum insurance with companies duly approved to do business in the State of Texas and satisfactory to the OWNER. Certificates of each policy shall be delivered to the OWNER before any work is started, along with a written statement from the issuing company stating that said policy shall not be canceled, nonrenewed or materially changed without 60 days advance written notice being given to the OWNER.

In addition to any coverage required by Texas Law, the CONTRACTOR shall provide the following coverages at not less than the specified amounts:

- 4.2 Workers Compensation insurance required by Texas Law at statutory limits, including employer's liability coverage at \$1,000,000. In addition to these, the CONTRACTOR must comply with all the requirements of the Texas Department of Insurance, Division of Workers' Compensation; (Note: If you have questions concerning these requirements, you are instructed to contact the DWC.)

By signing this contract or providing or causing to be provided a certificate of coverage, the CONTRACTOR is representing to the OWNER that all employees of the CONTRACTOR and its subcontractors who will provide services on the Project will be covered by workers compensation coverage for the duration of the Project, that the

coverage will be based on proper reporting of classification codes and payroll amounts, and that all coverage agreements will be filed with the appropriate insurance carrier or, in the case of a self-insured, with the commission's Division of Self-Insurance Regulation. Providing false or misleading information may subject the CONTRACTOR to administrative penalties, criminal penalties, civil penalties, or other civil actions.

The CONTRACTOR'S failure to comply with any of these provisions is a breach of Contract by the Contractor which entitles the OWNER to declare the Contract void if the CONTRACTOR does not remedy the breach within ten (10) days after receipt of notice of breach from the OWNER.

- 4.3 Broad form commercial general liability insurance, including independent contractor's liability, completed operations and contractual liability, written on an occurrence form, covering, but not limited to, the liability assumed under the indemnification provisions of this contract, fully insuring CONTRACTOR'S (or subcontractor's) liability for injury to or death of OWNER'S employees and third parties, extended to include personal injury liability coverage with damage to property, with minimum limits as set forth below:

General Aggregate \$2,000,000

Completed Products — Components/Operations Aggregate \$2,000,000

Personal and Advertising Injury \$ 1,000,000

Each Occurrence \$ 2,000,000

4.3.1 The policy shall include coverage extended to apply to completed operations, asbestos hazards (if this project involves work with asbestos) and XCU (explosion, collapse and underground) hazards. The completed operations coverage must be maintained for a minimum of one year after final completion and acceptance of the work, with evidence of same filed with OWNER.

- 4.4 Comprehensive automobile and truck liability insurance, covering owned, hired and non-owned vehicles, with a combined bodily injury and property damage minimum limit of \$1,000,000 per occurrence; or separate limits of \$1,000,000 for bodily injury (per person), \$1,000,000 for bodily injury (per accident) and \$1,000,000 for property damage. Such insurance shall include coverage for loading and unloading hazards.

#### 4.5 OWNER'S PROTECTIVE LIABILITY INSURANCE

CONTRACTOR shall obtain, pay for and maintain at all times during the prosecution of the work under this contract an OWNER'S protective liability insurance policy naming the OWNER as insured for property damage and bodily injury, which may arise in the prosecution of the Work or CONTRACTOR'S operations under this Contract. Coverage shall be on an "occurrence" basis, and the policy shall be issued by the same insurance company that carries the CONTRACTOR'S liability insurance with a combined bodily injury and property damage minimum limit of \$1,000,000 per occurrence and \$2,000,000 aggregate.

#### 4.6 “UMBRELLA” LIABILITY INSURANCE

CONTRACTOR shall obtain, pay for and maintain umbrella liability insurance during the contract term, insuring CONTRACTOR for an amount of not less than \$1,000,000 per occurrence combined limit for bodily injury and property damage that follows from and applies in excess of the primary liability coverages required hereinabove. The policy shall provide “drop down” coverage where underlying primary insurance coverage limits are insufficient or exhausted. OWNER shall be named as an additional insured.

#### 4.7 RAILROAD PROTECTIVE INSURANCE

When required in the Special Provisions, CONTRACTOR shall obtain, maintain and present evidence of railroad protective insurance (RPI). The policy shall be in the name of the railroad company having jurisdiction over the right-of-way involved. The minimum limit of coverage shall meet the specifications provided by the railroad company. The OWNER shall specify the amount of RPI necessary.

#### 4.8 POLICY ENDORSEMENTS AND SPECIAL CONDITIONS

Each insurance policy to be furnished by CONTRACTOR shall include the following conditions by endorsement to the policy:

- A. each policy shall name the OWNER as an additional insured as to all applicable coverage;
- B. each policy shall require that 60 days prior to the cancellation, nonrenewal or any material change in coverage, a notice thereof shall be given to OWNER by certified mail;
- C. the term “OWNER” shall include all past, present or future, authorities, boards, bureaus, commissions, divisions, departments and offices of the OWNER and individual members, elected official, officers, employees and agents thereof in their official capacities and/or while acting on behalf of the OWNER;
- D. the policy phrase “other insurance” shall not apply to the OWNER where the OWNER is an additional insured on the policy;
- E. all provisions of the contract concerning liability, duty and standard of care together with the indemnification provision, shall be underwritten by contractual liability coverage sufficient to include such obligations within applicable policies;
- F. all policies shall contain a waiver of subrogation in favor of OWNER, and its, past, present and future, officials, employees, and volunteers; and,
- G. each certificate of insurance shall reference the Project and Contract number, contain all the endorsement required herein, and require a notice to the OWNER of cancellation.

Insurance furnished by the CONTRACTOR shall be in accordance with the following requirements:



- A. any policy submitted shall not be subject to limitations, conditions or restrictions deemed inconsistent with the intent of the insurance requirements to be fulfilled by the CONTRACTOR. The OWNER'S decision thereon shall be final;
- B. all policies are to be written through companies duly licensed to transact that class of insurance in the State of Texas with a financial ratings of A+VII or better as assigned by BEST Rating Company or equivalent; and
- C. All liability policies required herein shall be written with an "occurrence" basis coverage trigger.

CONTRACTOR agrees to the following:

- A. CONTRACTOR hereby waives subrogation rights for loss or damage to the extent same are covered by insurance. Insurers shall have no right of recovery or subrogation against the OWNER, it being the intention that the insurance policies shall protect all parties to the Contract and be primary coverage for all losses covered by the policies;
- B. Companies issuing the insurance policies and CONTRACTOR shall have no recourse against the OWNER for payment of any premiums or assessments for any deductibles, as all such premiums and deductibles are the sole responsibility and risk of the CONTRACTOR;
- C. Approval, disapproval or failure to act by the OWNER regarding any insurance supplied by the CONTRACTOR (or any subcontractors) shall not relieve the CONTRACTOR of full responsibility or liability for damages and accidents as set forth in the Contract Documents. Neither shall the bankruptcy, insolvency or denial of liability by the insurance company exonerate the CONTRACTOR from liability; and
- D. No special payments shall be made for any insurance that the CONTRACTOR and subcontractors are required to carry; all are included in the Contract Price and the Contract unit prices. Any of such insurance policies required under this section may be written in combination with any of the others, where legally permitted, but none of the specified limits may be lowered thereby.

## **V. OWNERS RIGHTS AND RESPONSIBILITIES**

### **MONTHLY ESTIMATE, PARTIAL PAYMENTS AND FINAL PAYMENTS**

- 5.1 Progress and final payments shall be paid to the Contractor based upon the progress of the Project as indicated by the approved Applications for Payment, certificates of acceptance, or Certificates for Payment, that include an approved Schedule of Values that will be submitted by the CONTRACTOR to the OWNER prior to the commencement of the Work and in accordance with the following:
- 5.2 **MONTHLY ESTIMATES**

The CONTRACTOR shall deliver to the OWNER an itemized Application for Payment that shall include the work completed, materials stored at the Project site but not incorporated into the work, materials ready to be installed and stored at another agreed

location, and the percentage of Work completed, through the 20<sup>th</sup> day of each month, on an Application for Payment with a schedule of values previously submitted by the Contractor and approved by the Owner. Prior to release of funds in connection with any Application for Payment, the Owner may request, and the Contractor must provide, properly executed statements of full or partial releases of claims acceptable to Owner in form and content, for all persons or entities supplying labor or materials to the Project.

5.2.1 The Application for Payment is a representation by the CONTRACTOR to the OWNER that the construction has progressed to the point indicated, the quality of the Work covered by the application is in accordance with the Contract Documents, and the Contractor is entitled to payment in the amount requested.

#### 5.2.2 INSPECTION AND PARTIAL PAYMENTS

Whenever the CONTRACTOR shall submit an Application for Payment to the OWNER for work performed by the CONTRACTOR, the CONTRACTOR shall notify the Architect that the improvement is ready for inspection. The Architect shall then make such inspection, and will have the authority to reject work that does not conform to the Contract Documents. If the work is satisfactory and in accordance with the specifications and Contract Documents, the Architect shall issue a Certificate for Payment.

5.2.3 Within thirty (30) days of the Owner's receipt of a properly submitted and correct Application for Payment, and the issuance of a Certificate for Payment, the Owner shall make payment to the Contractor, in the amount approved by the Owner less 5% retainage. Such payment shall be adjusted for work that is incomplete or not in accordance with the Contract Documents or that is the subject of a separate contract, or subcontract or supplier claim or lien against the Contractor or the payment bonds for the project.

5.2.4 No partial or final payment or the entire use or occupancy of the Project by the OWNER shall be considered acceptance of work that does not strictly comply with the Contract Documents or release the CONTRACTOR of any of his responsibilities under the Contract.

#### 5.2.5 PAYMENT FOR LABOR AND MATERIAL; NO LIENS

The CONTRACTOR for himself or any of his subcontractors shall pay all indebtedness which may become due to any person, firm or corporation having furnished labor, material or both in the performance of this Contract. It shall be the responsibility of each person, firm or corporation claiming to have furnished labor, materials or both, in connection with this Contract, to protect his or its interest in the manner prescribed by applicable laws of the State of Texas, provided, however, that as this Contract provides for a public works project, no lien of any kind shall ever exist or be placed against the Work or any portion thereof, or any public funds or retainage held by the OWNER; and any subcontractor shall look solely to the

CONTRACTOR and the payment bond surety, and not the OWNER, for payment of any outstanding amounts due for labor, materials or any other indebtedness in connection with the Work. However, the OWNER may, at any time prior to making final payment, require the CONTRACTOR to furnish a Consent of Surety to any payment due the CONTRACTOR for completed work and may, at the discretion of the OWNER or the request of the Surety, make the check jointly payable to the CONTRACTOR and the Surety. The Owner shall have no obligation under this Agreement to pay or to be responsible in any way for payment to any, Architect, another design professional, contractor, subcontractor or supplier performing portions of the Work, pursuant to a contract with the Contractor.

#### 5.2.6 PAYMENT WITHHELD

In addition to express provisions elsewhere contained in the contract, the OWNER may withhold from any payment otherwise due the CONTRACTOR such amount as determined necessary to protect the OWNER'S interest, or, if it so elects, may withhold or retain all or a portion of any progress payment or refund payment on account of:

- A. unsatisfactory progress of the Work not caused by conditions beyond the CONTRACTOR'S control,
- B. defective work not corrected,
- C. CONTRACTOR'S failure to carry out instructions or orders of the OWNER or his representative,
- D. a reasonable doubt that the Contract can be completed for the balance then unpaid,
- E. work or execution thereof not in accordance with the Contract Documents,
- F. claim filed by or against the CONTRACTOR or reasonable evidence indicating probable filing of claims,
- G. failure of the CONTRACTOR to make payments to subcontractor or for material or labor,
- H. damage to another contractor,
- I. unsafe working conditions allowed to persist by the CONTRACTOR,
- J. failure of the CONTRACTOR to provide work schedules as required by the OWNER,
- K. use of subcontractors without the OWNER'S approval or,
- L. failure of the CONTRACTOR to keep current as-built record drawings at the job site or to turn same over in completed form to the OWNER.

When the above grounds are removed, payment shall be made for amounts withheld because of them, and OWNER shall never be liable for interest on any delayed or late payment.

#### 5.2.7 PAYMENT FOR EXTRA WORK

The extra work done by the CONTRACTOR as authorized and approved by the Architect shall be paid for in the manner hereinafter described, and the

compensation thus provided shall be accepted by the CONTRACTOR as payment in full for all labor, materials, tools, equipment and incidentals and all superintendents' and timekeepers' services, all insurance, bond and all other overhead expense incurred in the performance of the extra work.

Payment for extra work shall be made by one of the following methods:

A. Method "A" — by unit prices agreed on in writing by the OWNER and CONTRACTOR before said extra work is commenced, subject to all other conditions of the contract.

B. Method "B" — by lump sum price agreed on in writing by the OWNER and the CONTRACTOR before said extra work is commenced, subject to all other conditions of the contract.

#### 5.2.8 SUBSTANTIAL COMPLETION

The Project will be considered substantially complete when the OWNER can utilize the Project for its intended purpose and the Work is in conformance with the Contract Documents.

### 5.3 APPLICATION FOR FINAL PAYMENT.

Upon full performance of all the Contract Work and the full performance of all the provisions of the Contract, the CONTRACTOR shall submit a final application for payment to the OWNER, the CONTRACTOR shall notify the Architect that the improvement is ready for inspection. All warranties and guaranties required of the CONTRACTOR by the Contract Documents shall be assembled and delivered by the CONTRACTOR to the OWNER as Part of the final Application for Payment. The Contractor will assign to the Owner all manufacturer's warranties relating to materials and labor used in the work and will perform the Work in such a manner as to preserve all such manufacturer's warranties. The CONTRACTOR will deliver a certificate evidencing that insurance and bonds required by the Contract Documents will remain in full force and effect pursuant to the requirements of the Contract. The final Certificate for Payment will not be issued until all such warranties and guaranties have been received and accepted by the Owner, and a Certificate of Acceptance is issued by the or Architect.

#### 5.3.1 FINAL INSPECTION AND ACCEPTANCE

Whenever the improvements provided for by the Contract shall have been completely performed on the part of the CONTRACTOR, the CONTRACTOR shall notify the OWNER, and Architect that the improvement is ready for final inspection. The Architect shall then make such final inspection, and if the work is satisfactory and in accordance with the specifications and Contract Documents, the CONTRACTOR shall be issued a certificate of acceptance.

#### 5.3.2 FINAL PAYMENT

Whenever the improvements provided for by the Contract shall have been completely performed on the part of the CONTRACTOR, as evidenced in the certificate of acceptance, and all required submissions provided to the OWNER, a final estimate showing the value of the work shall be prepared by the Architect as soon as the necessary measurements and computations can be made. All prior estimates upon which payments have been made are subject or necessary corrections or revisions in the final payment. The amount of this final estimate, less any sums that have been previously paid, or deducted under the provisions of the Contract, shall be paid the CONTRACTOR within 30 days after the final acceptance, provided that the CONTRACTOR has furnished to the OWNER a consent of surety and an affidavit or other satisfactory evidence that all indebtedness connected with the Work and all sums of money due for any labor, materials, apparatus, fixtures or machinery furnished for and used in the performance of the work have been paid or otherwise satisfied, or that the person or persons to whom the same may respectively be due have consented to such final payment.

The acceptance by the CONTRACTOR of the final payment as aforesaid shall operate as and shall be a release to the OWNER from all claims or liabilities under the Contract, including all subcontractor claims, for anything done or furnished or relating to the Work under the Contract or for any act or neglect of said OWNER relating to or connected with the Contract.

All warranties and guarantees shall commence from the date of the certificate of acceptance. No interest shall be due the CONTRACTOR on any partial or final payment or on the retainage.

### **5.3 MODIFICATIONS TO CONTRACT WORK OR TIME OF PERFORMANCE**

#### **5.3.1 OWNER'S RIGHT TO TEMPORARILY SUSPEND WORK**

#### **5.3.2 REASONS FOR SUSPENSION**

The OWNER shall have the right by written order to temporarily suspend the work, in whole or in part, whenever, in the judgment of the OWNER, such temporary suspension is required:

- A. in the interest of the OWNER generally,
- B. due to government or judicial controls or orders which make performance of this contract temporarily impossible or illegal,
- C. to coordinate the work of separate contractors at the job site,
- D. to expedite the completion of a separate contract even though the completion of this particular Contract may be thereby delayed,

- E. because of weather conditions unsuitable for performance of the Work, or
- F. because the CONTRACTOR is proceeding contrary to contract provisions or has failed to correct conditions considered unsafe for workmen.

The written order of the OWNER to the CONTRACTOR shall state the reasons for suspending the work and the anticipated periods for such suspension. Upon receipt of the OWNER'S written order, the CONTRACTOR shall suspend the work covered by the order and shall take such means and precautions as may be necessary to properly protect the finished and partially finished work, the unused materials and uninstalled equipment, including the providing of suitable drainage about the work and erection of temporary structures where necessary. The CONTRACTOR shall not suspend the Work without written direction from the OWNER and shall proceed with the work promptly when notified by the OWNER to resume operations.

### 5.3.3 NO ADDITIONAL COMPENSATION

No additional compensation shall be paid to the CONTRACTOR for a temporary suspension of the Work by the OWNER or otherwise where same is caused by the fault of the CONTRACTOR. Where such temporary suspension is not due to the fault of the CONTRACTOR, he shall be entitled to:

- A. an equitable extension of working time for the completion of the work, not to exceed the delay caused by such temporary suspension, as determined by the OWNER; and
- B. the actual and necessary costs of properly protecting the finished and partially finished work, unused materials and uninstalled equipment during the period of the ordered suspension as determined by the OWNER as being beyond the Contract requirements, such costs, if any, to be determined pursuant to the terms of the Contract; and
- C. where the CONTRACTOR elects to move equipment from the job site and then return it to the site when the work is ordered resumed, the actual and necessary costs of these moves, in an amount determined by the OWNER pursuant to the terms of the Contract.

### 5.3.4 USE OF COMPLETED PORTIONS OF WORK

The OWNER may, after written notice to the CONTRACTOR, and without incurring any liability for increased compensation to the CONTRACTOR, take over and use any completed portion of the Work prior to the final completion and acceptance of the entire work included in the Contract, and notwithstanding that the time allowed for final completion has not expired. The OWNER and CONTRACTOR agree that occupancy of portions of the Work by the OWNER

shall not in any way evidence the substantial completion of the entire work or signify the OWNER's acceptance of the Work.

The CONTRACTOR shall not object to, nor interfere in any way with, such occupancy or use after receipt of the OWNER'S written notice. Immediately prior to such occupancy and use, the OWNER shall inspect such portion of the Work to be taken over and shall furnish the CONTRACTOR a written statement of the work, if any, still to be done on such part. The CONTRACTOR shall promptly thereafter complete such unfinished work to permit occupancy and use on the date specified in the OWNER'S written order, unless the OWNER shall permit specific items of work to be finished after the occupancy and use by the OWNER.

In the event the CONTRACTOR is unreasonably delayed by the OWNER exercising its rights under this section, the CONTRACTOR may submit a request for an extension of time; CONTRACTOR'S sole remedy for an unreasonable delay shall be an extension of time and shall not be entitled to any additional compensation.

#### 5.4 COMMENCEMENT; TIME OF COMPLETION; DELAYS; EXTENSION OF TIME; LIQUIDATED DAMAGES

##### 5.4.1 COMMENCEMENT; TIME OF COMPLETION

Contractor shall commence work within ten (10) consecutive calendar days after receiving from County a notice to proceed. Contractor agrees and covenants that the number of consecutive calendar days allowed to complete all work following a notice to proceed shall be as follows:

---

##### 5.4.2. LIQUIDATED DAMAGES FOR FAILURE TO COMPLETE ON TIME

Time is of the essence in the progress and completion of this Contract. For each calendar day that any Work shall remain uncompleted after the time specified in the proposal and the Contract, or the increased time granted by the OWNER, or as equitably increased by additional work or materials ordered after the Contract is signed, the sum per day given in the following schedule, unless otherwise specified in the special provisions, shall be deducted from the monies due the CONTRACTOR:

Five Hundred Fifty Dollars and Zero Cents (\$550.00)

The sum of money thus deducted for such delay, failure or noncompletion is not to be considered as a penalty, but shall be deemed, taken and treated as reasonable liquidated damages, per calendar day that the CONTRACTOR shall be in default after the time stipulated in the Contract for completing the Work. The said amounts

are fixed and agreed upon by and between OWNER and CONTRACTOR because of the impracticability and extreme difficulty of fixing and ascertaining the actual damages the OWNER in such event would sustain; and said amounts are agreed to be the amount of damages which the OWNER would sustain and which shall be retained from the monies due, or that may become due, the CONTRACTOR under this Contract; and if said monies be insufficient to cover the amount owing, then the CONTRACTOR or his surety shall pay any additional amounts due.

#### 5.4.3 EXTENTIONS OF TIME

The CONTRACTOR shall be entitled to an extension of working time under this Contract only when claim for such extension is submitted to the OWNER in writing by the CONTRACTOR within seven days from and after the time when any alleged cause of delay shall occur, and then only when such time is approved by the OWNER. In adjusting the Contract working time for the completion of the Project, unforeseeable causes beyond the control and without the fault or negligence of the CONTRACTOR, including, acts of God or the public enemy, acts of the OWNER, fires, floods, epidemics, quarantine restrictions, strikes, freight embargoes, or delays of subcontractors due to such causes beyond their control shall be taken into consideration.

If the satisfactory execution and completion of the Contract should require work and materials in greater amounts or quantities than those set forth in the Contract, requiring more time for completion than the anticipated time, then the contract working time shall be equitably increased, but not more than in the same proportion as the cost of the additional work bears to the cost of the original work contracted for. No allowances shall be made for delays or suspension of the performance of the Work due to the fault of the CONTRACTOR.

No adjustment to working time shall be made if, concurrently with the equitable cause for delay, there existed a cause for delay due to the fault or negligence of the CONTRACTOR, his agents, employees or subcontractors; and no adjustment shall be made to the Contract Price and the CONTRACTOR shall not be entitled to claim or receive any additional compensation as a result of or arising out of any delay resulting in adjustment to the working time hereunder, including delays caused by the acts or negligence of the OWNER. Notwithstanding any other provision of the Contract Documents, all claims for extension of working time must be submitted in accordance with the provisions of this Contract, and no act of the OWNER shall be deemed a waiver or entitlement of such extension.

### 5.5 TERMINATION FOR CONVENIENCE OF THE OWNER

#### 5.5.1 NOTICE OF TERMINATION

The performance of the Work under this Contract may be terminated by the OWNER in whole or from time to time in part, in accordance with this section,



whenever the OWNER shall determine that such termination is in the best interest of the OWNER. Any such termination shall be effected by mailing a notice of termination to the CONTRACTOR specifying the extent to which performance of work under the Contract is terminated, and the date upon which such termination becomes effective. Receipt of the notice shall be deemed conclusively presumed and established when the letter is placed in the United States Mail by the OWNER. Further, it shall be deemed conclusively presumed and established that such termination is made with just cause as therein stated; and no proof in any claim, demand or suit shall be required of the OWNER regarding such discretionary action.

#### 5.5.2 CONTRACTOR ACTION

After receipt of a notice of termination, and except as otherwise directed by the OWNER or Architect, the CONTRACTOR shall:

- A. stop work under the Contract on the date and to the extent specified in the notice of termination;
- B. place no further orders or subcontracts for materials, services or facilities except as may be necessary for completion of such portion the Work under the Contract as is not terminated;
- C. terminate all orders and subcontracts to the extent that they relate to the performance of work terminated by the notice of termination;
- D. transfer title to the OWNER and deliver in the manner, at the times, and to the extent, if any, directed by the OWNER or Architect:
  - 1. the fabricated or unfabricated parts, work in process, completed work, supplies and other material produced as a part of, or acquired in connection with the performance of, the work terminated by the notice of termination; and
  - 2. the completed or partially completed plans, drawings, information and other property which, if the Contract had been completed, would have been required to be furnished to the OWNER.
- E. complete performance of such part of the work as shall not have been terminated by the notice of termination; and
- F. take such action as may be necessary, or as the Architect may direct, for the protection and preservation of the property related to its Contract which is in the possession of the CONTRACTOR and in which the OWNER has or may acquire an interest.

At a time not later than 30 days after the termination date specified in the notice of termination, the CONTRACTOR may submit to the OWNER a list, certified as to the quantity and quality, of any or all items of termination inventory not previously disposed of, exclusive of items the disposition of which has been directed or authorized by the Architect. Not later than 15 days thereafter, the OWNER shall accept title to such items and remove them or enter into a storage agreement covering the same, provided that the list submitted shall be subject to verification

by the Architect upon removal of the items, or, if the items are stored, within 45 days from the date of submission of the list, and provided that any necessary adjustments to correct the list as submitted shall be made prior to final settlement.

#### 5.5.3 TERMINATION CLAIM

Within 60 days after notice of termination, the CONTRACTOR shall submit his termination claim to the Architect in the form and with the certification prescribed by the OWNER. Unless one or more extensions in writing are granted by the OWNER upon request of the CONTRACTOR, made in writing within such 60-day period or authorized extension thereof, any and all such claims shall be conclusively deemed waived.

#### 5.5.4 AMOUNTS

The CONTRACTOR and OWNER may agree upon the whole or any part of the amount or amounts to be paid to the CONTRACTOR by reason of the total or partial termination of work pursuant hereto, provided that such agreed amount or amounts shall never exceed the total contract price as reduced by the amount of payments otherwise made and as further reduced by the Contract Price of work not terminated. The contract shall be amended accordingly, and the CONTRACTOR shall be paid the agreed amount. No amount shall be due for lost or anticipated profits. Nothing prescribing the amount to be paid to the CONTRACTOR in the event of failure of the CONTRACTOR and the OWNER to agree upon the whole amount to be paid to the CONTRACTOR by reason of the termination of work pursuant to this section, shall be deemed to limit, restrict or otherwise determine or affect the amount or amounts which may be agreed upon to be paid to the CONTRACTOR pursuant to this paragraph.

#### 5.5.5 FAILURE TO AGREE

In the event of the failure of the CONTRACTOR and the OWNER to agree, as provided herein, upon the whole amount to be paid to the CONTRACTOR by reason of the termination of work pursuant to this section, the OWNER shall determine, on the basis of information available to it, the amount, if any, due to the CONTRACTOR by reason of the termination and shall pay to the CONTRACTOR the amounts determined. No amount shall be due for lost or anticipated profits.

#### 5.5.6 DEDUCTIONS

In arriving at the amount due the CONTRACTOR under this section, there shall be deducted (a) all unliquidated advance or other payments on account theretofore made to the CONTRACTOR, applicable to the terminated portion of this contract; (b) any claim which the OWNER may have against the CONTRACTOR in connection with this Contract; and (c) the agreed price for or the proceeds of sale of

any materials, supplies or other things kept by the CONTRACTOR or sold, pursuant to the provisions of this clause, and not otherwise recovered by or credited to the OWNER.

#### 5.5.7 ADJUSTMENT

If the termination hereunder be partial prior to the settlement of the terminated portion of this Contract, the CONTRACTOR may file with the Owner a request in writing for an equitable adjustment of the price or prices specified in the Contract relating to the continued portion of the Contract (the portion not terminated by the notice of termination), and such equitable adjustment as may be agreed upon shall be made in such price or prices; nothing contained herein, however, shall limit the right of the OWNER and the CONTRACTOR to agree upon the amount or amounts to be paid to the CONTRACTOR for the completion of the continued portion of the Contract when said contract does not contain an established contract price for such continued portion.

#### 5.5.8 NO LIMITATION OF RIGHTS

Nothing contained in this section shall limit or alter the rights which the OWNER may have for termination of this Contract under any other provision of this Contract or any other right which OWNER may have for default or breach of contract by CONTRACTOR.

### 5.6 CONTRACTOR DEFAULT: OWNER'S RIGHT TO SUSPEND WORK AND ANNUL CONTRACT

The Work or any portion of the Work under contract shall be suspended immediately on written order of the OWNER declaring the CONTRACTOR to be in default. A copy of such notice shall be served on the CONTRACTOR'S surety. The contract may be annulled by the OWNER for any good cause or causes, among others of which special reference is made to the following:

- A. failure of the CONTRACTOR to start the work within 10 days from date specified in the written work order issued by the OWNER to begin the work;
- B. evidence that the progress of the work being made by the CONTRACTOR is insufficient to complete the work within the specified working time;
- C. failure of the CONTRACTOR to provide sufficient and proper equipment, materials or construction forces for properly executing the Work;
- D. evidence that the CONTRACTOR has abandoned the Work or discontinuance of the performance of the Work or any part thereof and failure to resume performance within a reasonable time after notice to do so;
- E. evidence that the CONTRACTOR has become insolvent or bankrupt, or otherwise financially unable to carry on the Work;
- F. deliberate failure on the part of the CONTRACTOR to observe any requirements of the specifications or to comply with any orders given by the Architect as provided for in the specifications;

G. failure of the CONTRACTOR to promptly make good any defects in materials or workmanship, or any defects of any nature, the correction of which has been directed in writing by the OWNER;

H. evidence of collusion for the purpose of illegally procuring a contract or perpetrating fraud on the OWNER in the construction of work under contract;

I. repeated violations of safe working procedures;

J. the filing by the CONTRACTOR of litigation against the OWNER prior to final completion of the Work. When the Work is suspended for any of the causes itemized above, or for any other cause or causes, the CONTRACTOR shall discontinue the Work or such part thereof as the OWNER shall designate, whereupon the surety may either at its option assume the Contract or that portion thereof which the OWNER has ordered the CONTRACTOR to discontinue and perform the same or, with the written consent of the OWNER, sublet the same, provided, however, that the surety shall exercise its option within two weeks after the written notice to discontinue the work has been served upon the CONTRACTOR and upon the surety or its authorized agents. The surety in such event shall assume the CONTRACTOR'S place in all respects and shall be paid by the OWNER for all work performed by it in accordance with the terms of the Contract, but in no event shall such payments exceed the contract amount, regardless of the cost to the surety to complete the Work.

In the event that the surety assumes the CONTRACTOR'S place, duties and responsibilities in the Contract, all monies remaining due the CONTRACTOR at the time of his default shall thereupon become due and payable to the surety as the work progresses, subject to all terms of the Contract. In case the surety does not, within the hereinabove specified time, exercise its obligation to assume the Contract or that portion thereof which the OWNER has ordered the CONTRACTOR to discontinue, then the OWNER shall have the power to complete by contract or otherwise, as it may determine, the Work herein described or such part thereof as it may deem necessary; and the CONTRACTOR hereto agrees that the OWNER shall have the right to take possession of or use any or all of the materials, plans, tools, equipment, supplies and property of every kind provided by the CONTRACTOR for the purpose of the Work and to procure other tools, equipment and materials for the completion of the same and to charge to the account of the CONTRACTOR the expense of said contract for labor, materials, tools, equipment and expenses incident thereto. The expense so charged shall be deducted by the OWNER out of such monies as may be due or may at any time thereafter become due the CONTRACTOR under and by virtue of the Contract or any part thereof.

The OWNER shall not be required to obtain the lowest bid for the work of completing the Contract, but the expenses to be deducted shall be the actual cost of such work. In case such expense is less than the sum which would have been payable under the contract if the same had been completed by the CONTRACTOR, then in such case the OWNER may pay the CONTRACTOR the difference in the cost, provided that the CONTRACTOR shall not be entitled to any claim for damages or for loss of anticipated profits.

In case such expense shall exceed the amount which would have been payable under the Contract if the same had been completed by the CONTRACTOR, the CONTRACTOR and his surety shall pay the amount of the excess to the OWNER on notice from the OWNER for excess due including any costs incurred by the OWNER, such as inspection, legal fees and liquidated damages. When any particular part of the Work is being carried out by the OWNER by contract or otherwise under the provisions of this section, the CONTRACTOR shall continue the remainder of the Work in conformity with the terms of the contract and in such manner as not to hinder or interfere with the performance of workmen employed as above provided by the OWNER or surety.

#### 5.7 SUSPENSION BY COURT ORDER AGAINST THE OWNER

The CONTRACTOR shall suspend such part or parts of the Work pursuant to a court order issued against the OWNER and shall not be entitled to additional compensation by virtue of such court order; neither shall the CONTRACTOR be liable to the OWNER in the event the Work is suspended by such court order, unless such suspension is due to the fault or negligence of the CONTRACTOR. A delay of the CONTRACTOR due to a court order against the OWNER, or due to the OWNER'S failure to secure right-of-way at the time required or because of a conflict of a utility with the Work, shall not be cause for additional compensation for damages sustained by the CONTRACTOR, but may be a cause for extension of contract working time only. The CONTRACTOR'S sole remedy for any suspensions of the Work is an equitable extension of time to perform the Work.

#### 5.8 NO WAIVER OF RIGHTS OR ESTOPPEL

The OWNER, or any officer or agent thereof, shall not be precluded at any time, either before or after final completion and acceptance of the Work and final payment therefore from:

A. showing the true and correct amount, classifications, quality and character of the Work done and materials furnished by the CONTRACTOR or any other person under this Contract, or from showing at any time that any determination, return, decision, approval, order, letter, payment or certification is untrue and incorrect or improperly made in any particular, or that the Work or the materials or any parts thereof do not in fact conform to the contract requirements; and (b) demanding the recovery from the CONTRACTOR of any overpayments made to him, or such damages as the OWNER may sustain by reason of the CONTRACTOR'S failure to perform each and every part of this Contract in strict accordance with its terms; or both.

### **VI. AUTHORITY OF THE ARCHITECT**

6.1 All work shall be performed in a good and workmanlike manner and to the satisfaction of the Architect. The Architect shall decide all questions which arise as to the quality and acceptability of materials furnished, work performed, manner of performance, rate of progress of the work, sequence of the construction, interpretation of the plans and

specifications, acceptable fulfillment of the Contract, compensation, mutual rights between contractors under these specifications and suspension of the Work. He shall determine the amount and quality of work performed and materials furnished, and his decisions and estimates shall be final. His estimate in such event shall be a condition precedent to the right of the CONTRACTOR to receive money due him under the Contract.

## 6.2 OWNER'S REPRESENTATIVES

Where the Contract Documents indicate that determinations, directions or approvals shall be made by the OWNER or "Owner's representatives," this shall mean the OWNER acting directly, or through duly authorized persons acting within the limit of authority delegated to them. Any determination, direction or approval of such authorized representatives shall be subject to review by the OWNER. For purposes of administering the schedule or the payment provisions of this Contract the Architect may act as the Owner's representative for purposes of approving payments, changes, scheduling, or acceptance of the Work, at the OWNER'S discretion.

## 6.3 INSPECTIONS OF WORK PROGRESS

The Architect shall visit the site at during construction of the Project as necessary as the Owner's Representative to verify that the Work is being performed in compliance with the Contract Documents and shall be given total access to the Project by the CONTRACTOR. Site visits or inspections by the Architect shall in no way relieve the CONTRACTOR of any of its responsibilities or duties pursuant to the Contract Documents. The Architect will neither have control over, nor be responsible for, the construction means and methods, techniques, sequences, or procedures, or for the safety precautions and programs in connection with the Work or the Project. The CONTRACTOR shall be solely responsible for, the construction means and methods, techniques, sequences, or procedures, or for the safety precautions and programs in connection with the Work or the Project.

## 6.4 CONSTRUCTION STAKES

Architect will provide the Contractor with primary horizontal and vertical control to consist of one construction baseline and two benchmarks.

The Contractor shall take all necessary precautions to preserve any and/or all markings and staking. Payment for costs of restaking shall be the responsibility of the Contractor.

## 6.5 APPROVAL OF SUBMITTALS

The Architect shall review and approve or take other appropriate action the CONTRACTOR's submittals such as Shop Drawings, Product Data and Samples, for the purpose of checking for conformance with the Contract Documents. The Architects review of the submittals shall not relieve the CONTRACTOR of any of its obligations to perform the Work in strict compliance with the Contract Documents. The Architect's review shall

not be considered approval of safety precautions, means and methods, techniques, sequences or procedures that are the responsibility of the CONTRACTOR.

## **VII. CLAIMS OR DISPUTES**

### **7.1 CLAIMS AGAINST OWNER AND ACTION THEREON.**

No claim against the OWNER under the Contract or for breach of the Contract or additional compensation for extra or disputed work shall be made or asserted against the OWNER under the Contract or in any court action, unless the CONTRACTOR shall have strictly complied with all requirements relating to the giving of notice and information with respect to such claim as required by the Contract.

### **7.2 CLAIM AGAINST OFFICERS, EMPLOYEES OR AGENT OF THE OWNER.**

No claim whatsoever shall be made by the CONTRACTOR against any, past, present or future, officer, employee or agent of the OWNER for or on account of, anything done or omitted to be done in connection with this Contract.

## **VIII. MISCELLANEOUS PROVISIONS**

### **8.1 FINANCIAL INTEREST IN ANY CONTRACT BY OWNER'S OFFICERS, EMPLOYEES OR AGENTS**

No officer, employee or agent of the OWNER shall have a financial interest, direct or indirect, in any contract with the OWNER or be financially interested, directly or indirectly, in the sale to the OWNER of any land, materials, supplies or services, except on behalf of the OWNER as an officer or employee. Any willful violation of this article shall constitute malfeasance in office, and any officer or employee guilty thereof shall thereby forfeit his office or position. Any violation of this article with the knowledge, expressed or implied, of the persons, partnership, company, firm, association or corporation contracting with the OWNER shall render the contract involved voidable by the OWNER.

### **8.2 SERVICE OF NOTICES**

The OWNER and the CONTRACTOR shall each designate addresses where all notices, directions or other communication may be delivered or to which they may be mailed.

Notices to the surety or sureties on contract bonds shall be directed or delivered to the home office, or to the agent or agents who executed the bonds on behalf of the surety or sureties, or to their designated agent for delivery of notices.

Actual delivery of any such notice, direction or communication to the aforesaid places or depositing it in a postpaid wrapper addressed thereto in any post office regularly maintained by the United States Postal Service shall be conclusively deemed to be sufficient service thereof upon the above persons as of the date of such delivery or deposit.

The designated addresses may be changed at any time by an instrument in writing executed by the party changing the addresses and delivered to the other party.

Nothing herein contained shall, however, be deemed to preclude or tender inoperative the service of any notice, direction or communication upon the above parties personally or, if the CONTRACTOR be a corporation, upon any officer or director thereof.

### 8.3 UNLAWFUL PROVISIONS DEEMED STRICKEN

In the event a term, condition, or provision of this Agreement is determined to be void, unenforceable, or unlawful by a court of competent jurisdiction, then that term, condition, or provision shall be deleted and the remainder of the Agreement shall remain in full force and effect.

### 8.4 ALL LEGAL PROVISIONS INCLUDED

It is the intent and agreement of the parties to this contract that all legal provisions of law required to be inserted herein shall be and are inserted herein. If through mistake or oversight, however, any such provision is not herein inserted, or is not inserted in proper form, then upon application of either party, the contract shall be amended so as to strictly comply with the law and without prejudice to the rights of either party hereunder.

### 8.5 ASSIGNMENTS

The CONTRACTOR shall not assign, transfer, convey or otherwise dispose of this contract, or his right to execute it, or his right, title or interest in it or any part thereof without the previous written consent of the surety company and the written approval of the OWNER.

The CONTRACTOR shall not assign, either legally or equitably, by power of attorney or otherwise, any of the monies due or to become due under this Contract or its claim thereto without the prior written consent of the surety company and the written approval of the OWNER.

The approval of the OWNER of a particular assignment, transfer or conveyance shall not dispense with such approval to any further or other assignments.

The approval by the OWNER of any assignment, transfer or conveyance shall not operate to release the CONTRACTOR or surety hereunder from any of the Contract and bond obligations, and the CONTRACTOR shall be and remain fully responsible and liable for the defaults, negligent acts and omissions of his assignees, their agents and employees, as if they were his own.

### 8.6 STATE AND LOCAL SALES AND USE TAXES



The OWNER qualifies for exemption from the state and local sales and use taxes, pursuant to the provisions of Section 151.309 of the Texas Limited Sales, Excise and Use Tax Act. Therefore, the CONTRACTOR shall not pay such taxes which would otherwise be payable in connection with the performance of this Contract.

The CONTRACTOR shall issue an exemption certificate in lieu of the tax on the purchase, rental or lease of:

- A. all materials, supplies, equipment and other tangible personal property incorporated into the real property being improved; and
- B. all materials, supplies, equipment and other tangible personal property used or consumed by the CONTRACTOR in performing the Contract with the OWNER. Materials and supplies “used in the performance of a contract” include only those materials actually incorporated into the property being improved and those supplies directly used to incorporate such materials into the property being improved. Overhead supplies and supplies used indirectly or only incidental to the performance of the Contract with the OWNER are not included in the exemption.

Under “reasons said purchaser is claiming this exemption” in the exemption certificate, the CONTRACTOR must name the OWNER and the project for which the equipment, material and supplies are being purchased, leased or rented.

#### 8.7 VENUE AND GOVERNING LAW

The parties agree that the laws of the State of Texas shall govern the interpretation, validity, performance and enforcement of this Construction Agreement, and that the exclusive venue for any legal proceeding involving this Construction Agreement shall be in Collin County, Texas.

#### 8.8 NO WAIVER OF LEGAL RIGHTS

Inspection by the Architect, or OWNER; any order, measurement, quantity or certificate by the Architect; any order by the OWNER for payment of money; any payment for or acceptance of any work; or any extension of time or any possession taken by the OWNER shall not operate as a waiver of any provisions of the contract or any power therein reserved to the OWNER of any rights or damages therein provided. Any waiver of any breach of contract shall not be held to be a waiver of any other or subsequent breach. The OWNER reserves the right to correct any error that may be discovered in any estimate that may have been paid and to adjust the same to meet the requirements of the Contract Documents. The OWNER reserves the right to recover by process of law sums as may be sufficient to correct any error or make good any deficiency in the Work resulting from such error, dishonesty or collusion by the CONTRACTOR or his agents, discovered in the Work after the final payment has been made.

Neither final acceptance of the Work, nor final payment shall relieve the CONTRACTOR of responsibility for faulty materials or workmanship, and the CONTRACTOR shall

promptly remedy any defects due thereto and pay for any damage to other work resulting therefrom. Likewise, neither final acceptance nor final payment, nor partial or entire use or occupancy of the work by the OWNER shall constitute acceptance of work not done in accordance with the Contract Documents or relieve CONTRACTOR of liability with respect to any expressed or implied warranties or responsibility for faulty materials or workmanship, whether same be patently or latently defective.

8.9 OBLIGATION TO PERFORM FUNCTIONS

Any failure or neglect on the part of OWNER, Architect or inspectors to enforce provisions herein dealing with supervision, control, inspection, testing or acceptance and approval of the work shall never operate to relieve CONTRACTOR from full compliance with the Contract Documents nor render OWNER liable to CONTRACTOR for money damages, extensions of time or increased compensation of any kind.

8.10 SUCCESSORS AND ASSIGNS

Subject to the limitations upon assignment and transfer herein contained, this contract shall be binding upon and inure to the benefit of the parties hereto, their respective successors and assigns.

8.11 HEADINGS

The title and headings contained in the Contract Documents and the subject organization are used only to facilitate reference, and in no way define or limit the scope of intent of any of the provisions of this Contract.

8.12 ENTIRE AGREEMENT; AMENDMENTS; BINDING EFFECT

This Construction Agreement, including the Contract Documents and all the documents incorporated therein represents the entire and integrated agreement between the OWNER, Collin County, and the CONTRACTOR, and supersedes all prior negotiations, representations, or agreements, either written or oral. This Construction Agreement may be amended only by written instrument signed by both, the OWNER, Collin County, and the CONTRACTOR.

8.13 INTERPRETATION

Although this Agreement is drafted by the OWNER, Collin County, should any part be in dispute, the parties agree that this Construction Agreement shall not be construed more favorable for either party. No rule of construction requiring that ambiguities in this Contract shall be construed more favorably for either party shall apply.

8.14 EXPENSES FOR ENFORCEMENT

In the event either Party hereto is required to employ an attorney to enforce the provisions of this Agreement or is required to commence legal proceedings to enforce the provisions hereof, the prevailing Party shall be entitled to recover from the other, reasonable attorney's fees and court costs incurred in connection with such enforcement, including collection.

IN WITNESS WHEREOF, the parties have executed this Construction Agreement upon the year and date indicated beneath their signatures hereto.

**CONTRACTOR:**

\_\_\_\_\_

By: \_\_\_\_\_

Date: \_\_\_\_\_

**ATTEST:**

\_\_\_\_\_

Secretary

**COLLIN COUNTY, TEXAS:**

By: \_\_\_\_\_  
Michalyn Rains, CPPO, CPPB, Purchasing Agent

Date: \_\_\_\_\_

\_\_\_\_\_  
Collin County Commissioners' Court Order No.

**ATTEST:**

\_\_\_\_\_

Secretary

**APPROVED AS TO FORM:**

\_\_\_\_\_

**ACKNOWLEDGMENTS**

**STATE OF TEXAS** §

**COUNTY OF \_\_\_\_\_** §

**BEFORE ME,** \_\_\_\_\_ on this day personally appeared \_\_\_\_\_, of \_\_\_\_\_, a \_\_\_\_\_ corporation, known to me (or proved to me on the oath of) \_\_\_\_\_ or through \_\_\_\_\_ (description of identity card or other document) to be the person whose name is subscribed to the foregoing instrument and acknowledged to me that he/she executed the same as the act and deed of the corporation, for the purposes and consideration therein expressed and in the capacity therein stated.

**GIVEN UNDER MY HAND AND SEAL OF OFFICE,** this the \_\_\_ day of \_\_\_\_\_, 2018

\_\_\_\_\_  
Notary Public, State of Texas

\_\_\_\_\_  
Printed Name

My Commission expires on the \_\_\_\_ day of \_\_\_\_\_, \_\_\_\_\_.

**STATE OF TEXAS** §

**COUNTY OF COLLIN** §

**BEFORE ME,** \_\_\_\_\_ on this day personally appeared \_\_\_\_\_, Purchasing Agent of COLLIN COUNTY, TEXAS, a political subdivision of the State of Texas, known to me (or proved to me on the oath of) \_\_\_\_\_ or through \_\_\_\_\_ (description of identity card or other document) to be the person whose name is subscribed to the foregoing instrument and acknowledged to me that he/she executed the same as the act and deed of COLLIN COUNTY, TEXAS, for the purposes and consideration therein expressed and in the capacity therein stated.

**GIVEN** under my hand and seal of office this the \_\_\_\_\_ day of \_\_\_\_\_, 2018.

\_\_\_\_\_  
Notary Public, State of Texas

\_\_\_\_\_  
Printed Name

My Commission expires on the \_\_\_\_ day of \_\_\_\_\_, \_\_\_\_\_.



**006111 PERFORMANCE BOND**

STATE OF TEXAS §  
COUNTY OF COLLIN §

**KNOW ALL MEN BY THESE PRESENTS:**

That \_\_\_\_\_, a corporation organized and existing under the laws of the State of \_\_\_\_\_, and fully authorized to transact business in the State of Texas, whose address is \_\_\_\_\_ of the City of \_\_\_\_\_ County of \_\_\_\_\_, and State of \_\_\_\_\_, (hereinafter referred to as "Principal"), and \_\_\_\_\_ (hereinafter referred to as "Surety", a corporation organized under the laws of the State of \_\_\_\_\_ and authorized under the laws of the State of Texas to act as surety on bonds for principals, are held and firmly bound unto \_\_\_\_\_ (hereinafter referred to as "Owner") and unto all persons, firms and corporations who may furnish materials for or perform labor upon the buildings, structures or improvements referred to in the attached Contract, in the penal sum of \_\_\_\_\_ Dollars (\$ \_\_\_\_\_) (not less than 100% of the approximate total amount of the Contract as evidenced in the proposal plus 10-percent of the stated penal sum as an additional sum of money representing additional court expenses, attorneys' fees, and liquidated damages arising out of or connected with the below identified Contract) in lawful money of the United States, for the payment whereof, the said Principal and Surety bind themselves, and their heirs, administrators, executors, successors, and assigns, jointly and severally, firmly by these presents:

**WHEREAS**, the Principal has entered into a certain written contract with the Owner, dated the \_\_\_\_\_ day of \_\_\_\_\_, 201\_\_\_\_, to which said Contract is hereby referred to and made a part hereof and as fully and to the same extent as if copied at length herein for the construction of IFB 2018-162, Construction, Collin County Justice Center, Upgrade Pneumatic to Electronic Actuators.

**CONDITION OF THIS OBLIGATION IS SUCH**, that if the said Principal fully and faithfully executes the work and performance of the Contract in accordance with the plans specifications, and Contract Documents, including any extensions thereof which may be granted with or without notice to Surety, during the original term thereof, and during the life of any guaranty required under the Contract, and according to the true intent and meaning of said Contract and the plans and specifications hereto annexed, if the Principal shall repair and/or replace all defects due to faulty materials or workmanship that appear within a period of one year from the date of final completion and final acceptance of the work by OWNER; and if the Principal shall fully indemnify and save harmless the OWNER from all costs and damages which OWNER may suffer by reason of failure to so perform herein and shall fully reimburse and repay OWNER all outlay and expense which the OWNER may incur in making good any default or deficiency, then this obligation shall be void; otherwise, to remain in full force and effect; and in case said CONTRACTOR shall fail to do so, it is agreed that the OWNER may do said work and supply such materials and charge the same against said CONTRACTOR and Surety on this obligation. Provided further, that if any legal action be filed on this Bond, venue shall lie in Collin County, Texas.

**"PROVIDED, HOWEVER**, that this bond is executed pursuant to the provisions Texas Government Code, Chapter 2253, as amended, and Chapter 3503 of the Texas Insurance Code, as amended, and all liabilities on this bond shall be determined in accordance with the provisions of said articles to the same extent as if they were fully copied at length herein.

Surety, for value received, stipulates and agrees that the bond shall automatically be increased by the amount of any Change Order or supplemental agreement which increases the Contract price with or without notice to the Surety, but in no event shall a Change Order or Supplemental Agreement which reduces the Contract price decrease the penal sum of the Bond. And further that no change, extension of time, alteration, or addition to the terms of the Contract, or to the work performed thereunder, or the plans, specifications, or drawings accompanying the same shall in any way affect its obligation on this bond, and it does hereby waive notice of any such change, extension of time, alteration, or addition to the terms of the Contract or to the work to be performed thereunder.

Surety agrees that the bond provides for the repairs and/or replacement of all defects due to faulty materials and workmanship that appear within a period of one (1) year from the date of completion and acceptance of the improvement by the OWNER.

The undersigned and designated agent is hereby designated by Surety herein as the agent resident to whom any requisite notice may be delivered and on whom service of process may be had in matters arising out of such suretyship.

**IN WITNESS WHEREOF**, the said Principal and Surety have signed and sealed this instrument this \_\_\_\_\_ day of \_\_\_\_\_ 201\_\_\_\_.

**WITNESS**

\_\_\_\_\_

**PRINCIPAL**

\_\_\_\_\_  
Printed/Typed Name \_\_\_\_\_  
Title: \_\_\_\_\_  
Company: \_\_\_\_\_  
\_\_\_\_\_  
Address: \_\_\_\_\_  
\_\_\_\_\_

**WITNESS**

\_\_\_\_\_

**SURETY**

\_\_\_\_\_  
Printed/Typed Name \_\_\_\_\_  
Title: \_\_\_\_\_  
Company: \_\_\_\_\_  
\_\_\_\_\_  
Address: \_\_\_\_\_  
\_\_\_\_\_

The Resident Agent of the Surety for delivery of notice and service of process is:  
Name: \_\_\_\_\_  
Address: \_\_\_\_\_  
Phone Number: \_\_\_\_\_

**Note:** Date of Bond must NOT be prior to date of contract.

**006113 PAYMENT BOND**

STATE OF TEXAS            §  
COUNTY OF COLLIN       §

**KNOW ALL MEN BY THESE PRESENTS:**

That \_\_\_\_\_, a corporation organized and existing under the laws of the State of \_\_\_\_\_, and fully authorized to transact business in the State of Texas, whose address is \_\_\_\_\_ of the City of \_\_\_\_\_ County of \_\_\_\_\_, and State of \_\_\_\_\_, (hereinafter referred to as "Principal"), and \_\_\_\_\_ (hereinafter referred to as "Surety", a corporation organized under the laws of the State of \_\_\_\_\_ and authorized under the laws of the State of Texas to act as surety on bonds for principals, are held and firmly bound unto \_\_\_\_\_ (hereinafter referred to as "Owner") and unto all persons, firms and corporations who may furnish materials for or perform labor upon the buildings, structures or improvements referred to in the attached Contract, in the penal sum of \_\_\_\_\_ Dollars (\$ \_\_\_\_\_) (not less than 100% of the approximate total amount of the Contract as evidenced in the proposal) in lawful money of the United States, for the payment whereof, the said Principal and Surety bind themselves, and their heirs, administrators, executors, successors, and assigns, jointly and severally, firmly by these presents:

**WHEREAS**, the Principal has entered into a certain written contract with the Owner, dated the \_\_\_\_\_ day of \_\_\_\_\_, 201\_\_\_\_, to which said Contract is hereby referred to and made a part hereof and as fully and to the same extent as if copied at length herein for the construction of IFB 2018-162, Construction, Collin County Justice Center, Upgrade Pneumatic to Electronic Actuators

**NOW, THEREFORE, THE CONDITION OF THIS OBLIGATION IS SUCH**, that the bond guarantees the full and proper protection of all claimants supplying labor and material in the prosecution of the work provided for in said Contract and for the use of each claimant, and that conversely should the Principal faithfully perform said Contract and in all respects duly and faithfully observe and perform all and singular the covenants, conditions, and agreements in and by said Contract, agreed to by the Principal, and according to the true intent and meaning of said Contract and the claims and specifications hereto annexed, and any and all duly authorized modifications of said Contract that may hereafter be made, notice of which modification to Surety being hereby waived, then this obligation shall be void; otherwise, to remain in full force and effect. Provided further, that if any legal action be filed on this Bond, venue shall lie in Collin County, Texas.

**"PROVIDED, HOWEVER**, that this bond is executed pursuant to the provisions Texas Government Code, Chapter 2253, as amended, and Chapter 3503 of the Texas Insurance Code, as amended, and all liabilities on this bond shall be determined in accordance with the provisions of said articles to the same extent as if they were fully copied at length herein.

Surety, for value received, stipulates and agrees that the bond shall automatically be increased by the amount of any Change Order or supplemental agreement which increases the Contract price with or without notice to the Surety and that no change, extension of time, alteration or addition to the terms of the Contract, or to the work performed thereunder, or the plans, specifications, or drawings accompanying the same, shall in anyway affect its obligation on this bond, and it does hereby waive notice of any such change, extension of time, alteration or addition to the terms of the Contract, or to the work to be performed thereunder.

The undersigned and designated agent is hereby designated by Surety herein as the agent resident to whom any requisite notice may be delivered and on whom service of process may be had in matters arising out of such suretyship.

**IN WITNESS WHEREOF**, the said Principal and Surety have signed and sealed this instrument this \_\_\_\_\_ day of \_\_\_\_\_ 201\_\_\_\_.

**WITNESS**

\_\_\_\_\_

**PRINCIPAL**

\_\_\_\_\_

Printed/Typed Name \_\_\_\_\_

Title: \_\_\_\_\_

Company: \_\_\_\_\_

\_\_\_\_\_

Address: \_\_\_\_\_

\_\_\_\_\_

**SURETY**

\_\_\_\_\_

Printed/Typed Name \_\_\_\_\_

Title: \_\_\_\_\_

Company: \_\_\_\_\_

\_\_\_\_\_

Address: \_\_\_\_\_

\_\_\_\_\_

**WITNESS**

\_\_\_\_\_

The Resident Agent of the Surety for delivery of notice and service of process is:  
Name: \_\_\_\_\_  
Address: \_\_\_\_\_  
Phone Number: \_\_\_\_\_

**Note:**     Date of Bond must NOT be prior to date of contract.

**006119 MAINTENANCE BOND**

STATE OF TEXAS            §  
COUNTY OF COLLIN       §

**KNOW ALL MEN BY THESE PRESENTS:**

That \_\_\_\_\_, a corporation organized and existing under the laws of the State of \_\_\_\_\_, and fully authorized to transact business in the State of Texas, whose address is \_\_\_\_\_ of the City of \_\_\_\_\_ County of \_\_\_\_\_, and State of \_\_\_\_\_, (hereinafter referred to as "Principal"), and \_\_\_\_\_ (hereinafter referred to as "Surety", a corporation organized under the laws of the State of \_\_\_\_\_ and authorized under the laws of the State of Texas to act as surety on bonds for principals, are held and firmly bound unto \_\_\_\_\_ (hereinafter referred to as "Owner") and unto all persons, firms and corporations who may furnish materials for or perform labor upon the buildings, structures or improvements referred to in the attached Contract, in the penal sum of \_\_\_\_\_ Dollars (\$ \_\_\_\_\_) in lawful money of the United States, for the payment whereof, the said Principal and Surety bind themselves, and their heirs, administrators, executors, successors, and assigns, jointly and severally, firmly by these presents:

**WHEREAS**, the Principal has entered into a certain written contract with the Owner, dated the \_\_\_\_\_ day of \_\_\_\_\_, 201\_\_\_\_, to which said Contract is hereby referred to and made a part hereof and as fully and to the same extent as if copied at length herein for the construction of IFB 2018-162, Construction, Collin County Justice Center, Upgrade Pneumatic to Electronic Actuators.

**NOW, THEREFORE, THE CONDITION OF THIS OBLIGATION IS SUCH**, that the bond guarantees the full and proper maintenance and repair of the work herein contracted to be done and performed for a period of \_\_\_\_\_ year(s) from the date of acceptance and Principal will do all necessary backfilling that may arise on account of sunken conditions in ditches, or otherwise, and do and perform all necessary work and repair any defective condition growing out of or arising from the improper laying or construction of same, or on account of any breaking of same caused by said CONTRACTOR in construction of same, or on account of any defect arising in any of said work laid or constructed by said CONTRACTOR or on account of improper excavation or backfilling, it being understood that the purpose of this section is to cover all defective conditions arising by reason of defective materials, work or labor performed by said CONTRACTOR, then this obligation shall be void; otherwise, to remain in full force and effect; and in case said CONTRACTOR shall fail to do so, it is agreed that the OWNER may do said work and supply such materials and charge the same against said CONTRACTOR and Surety on this obligation. Provided further, that if any legal action be filed on this Bond, venue shall lie in Collin County, Texas.

**"PROVIDED, HOWEVER**, that said Surety, for value received, stipulates and agrees the bond shall automatically be increased by the amount of any Change Order or supplemental agreement which increases the Contract price with or without notice to the Surety and that no change, extension of time, alteration or addition to the terms of the Contract, or to the work performed thereunder, or the plans specifications, or drawings accompanying the same shall in any way affect its obligation on this bond, and it does hereby waive notice of any such change, extension of time, alteration, or addition to the terms of the Contract or to the work to be performed thereunder.

The undersigned and designated agent is hereby designated by Surety herein as the agent resident to whom any requisite notice may be delivered and on whom service of process may be had in matters arising out of such suretyship.

**IN WITNESS WHEREOF**, the said Principal and Surety have signed and sealed this instrument this \_\_\_\_\_ day of \_\_\_\_\_ 201\_\_\_\_.

**WITNESS**

\_\_\_\_\_

**PRINCIPAL**

Printed/Typed Name \_\_\_\_\_

Title: \_\_\_\_\_

Company: \_\_\_\_\_

Address: \_\_\_\_\_

**WITNESS**

\_\_\_\_\_

**SURETY**

Printed/Typed Name \_\_\_\_\_

Title: \_\_\_\_\_

Company: \_\_\_\_\_

Address: \_\_\_\_\_

The Resident Agent of the Surety for delivery of notice and service of process is:  
Name: \_\_\_\_\_  
Address: \_\_\_\_\_  
Phone Number: \_\_\_\_\_

**Note:** Date of Bond must NOT be prior to date of contract.



**SECTION 23 00 10 –MECHANICAL SUBMITTAL PROCESS**

**PART 1 – GENERAL**

**1.1 SUBMITTALS**

- A. Comply with all submittal provisions of Division 1.
- B. Submit electronic copies of the submittal to the prime consultant in order to process and track the submittals properly in accordance with Division 1 and 23 submittal requirements. Architects and consultants are to submit all submittals and RFI's to the mechanical engineer electronically. Send to "**mdengca@md-eng.com**". Submittals shall be labeled by their project specification section or CSI specification section if not listed in project specifications.
- C. Contractor is responsible to separate submittals per specification section. Unseparated submittals are subject to rejection without review.
- D. Allow a minimum of ten (10) working days for the review of submittals and each re-submittal.
- E. Submittals that have been reviewed and marked as REJECTED (REJ) or MAKE CORRECTIONS NOTED (MCN) should be resubmitted within 10 days to be reviewed again by engineer.
- F. Compliance with the Contract documents shall be the sole responsibility of the Contractor. Items on equipment that are were not accepted by the Architect in writing as an approved equal shall be replaced or revised to comply with the contract documents at the Contractor's expense.
- G. Resubmission of rejected submittals shall be limited to one (1) in number. Costs for processing subsequent resubmittals in excess of the first resubmittal, resulting from the Contractor's disregard of Architect/Engineer's primary submittal rejection comments, shall be borne by the Contractor. Costs shall be based on Architect/Engineer's hourly rates as published in their current professional fee schedules and shall also include reimbursable costs for delivery, mailing, and photocopies at direct cost plus ten percent (10%).

**1.2 REQUIRED SPECIFICATIONS (Project specific)**

- A. The chart below are the submittals required for the project.
  - 1. Submittals marked with an "**X**" are required for this project.
  - 2. Submittals without an "**X**" are not required for this project.

See required specifications on next page

Required X	Submittal Name	Spec Reference
X	<b>Common Work Results for HVAC</b> <i>-O&amp;M manual, Shop Drawings</i>	23 05 00
	<b>Common Motor Requirements for HVAC</b> <i>-Polyphase Motors, Single Phase Motors, -Motor Starters</i>	23 05 13
X	<b>Hangers &amp; Supports for HVAC Piping &amp; Equip.</b> <i>-Hangers and supports, Inserts, Hanger rods -Sleeves, Trapezes</i>	23 05 29
X	<b>Vibration &amp; Seismic Controls for HVAC Pipe, etc.</b> <i>-Isolation material, Support units,</i>	23 05 48
X	<b>Identification for HVAC Piping &amp; Equipment</b> <i>-Valve tags, Pipe markers, Equipment plates,</i>	23 05 53
X	<b>Testing, Adjusting &amp; Balancing for HVAC</b> <i>-Certifications</i>	23 05 93
X	<b>HAVC Insulation</b> <i>-Piping Insulation, Duct insulation, Adhesives -Sealants, Covers, Aluminum UV covers.</i>	23 07 00
X	<b>Instrumentation &amp; Control for HVAC</b> <i>-Shop drawings, Software, Equipment</i>	23 09 00
	<b>Direct-Digital Control System for HVAC</b> <i>-Product Details. See Spec for more details</i>	23 84 00
X	<b>Sequence of Operations for HVAC Controls</b> <i>-Control system, Shop drawings. Testing</i>	23 09 93
	<b>Facility Natural Gas Piping</b> <i>-Piping, Valves, Cocks, Regulators, Flanges</i>	23 11 23
	<b>Refrigeration Piping</b> <i>-Pipe, Fittings, Valves, Cocks, Hangers, Sleeves -Trapezes, Brazing Rod</i>	23 23 00
X	<b>Variable Frequency Motor Controllers (VFD)</b> <i>-Manufacturer, Product info</i>	23 29 23
X	<b>Air Distribution</b> <i>-Duct Work, Flexible duct, Access doors -Fire &amp; Smoke dampers</i>	23 31 00
	<b>Ventilation Ducts</b> <i>-Product Details. See Spec for more details</i>	23 31 13.01
	<b>Exterior Ducts</b> <i>-Product Details. See Spec for more details</i>	23 31 13.02
X	<b>Hangers &amp; Supports for Duct Work</b> <i>-duct hangers</i>	23 31 50
	<b>HVAC Power Ventilators</b> <i>-Up blast, Belt driven, Utility fans, V-belt</i>	23 34 23

Required X	Submittal Name	Spec Reference
	<b>Diffusers, Registers, Grills</b> <i>-Air supplies, Returns, Louvers, Roof hoods -Louvered penthouse, Goosenecks</i>	23 37 13
	<b>Commercial Kitchen Hoods</b> <i>-Product Data, Shop Drawings</i>	23 38 13
	<b>Heat Generation Equipment</b> <i>-Tubular Infrared Heaters, Heater flues</i>	23 50 00
	<b>Packaged Outdoor HVAC Equipment</b> <i>-Packaged Equipment, Controls, Hail Guards</i>	23 74 00
	<b>Dedicated OSA Units</b> <i>-Equipment</i>	23 75 00
	<b>DX Split System</b>	23 76 00
	<b>VRF Air Conditioning Systems (General)</b> <i>-VRF Equipment, Condenser, FCU, -Refrigeration selector boxes, Controls</i>	23 81 49
	<b>VRF Air Conditioning Systems (LG)</b> <i>-VRF Equipment, Condenser, FCU, -Refrigeration selector boxes, Controls</i>	23 81 49
	<b>VRF Air Conditioning Systems (Mitsubishi)</b> <i>-VRF Equipment, Condenser, FCU, -Refrigeration selector boxes, Controls</i>	23 81 49
	<b>VRF Air Conditioning Systems (Daikin)</b> <i>-VRF Equipment, Condenser, FCU, -Refrigeration selector boxes, Controls</i>	23 81 49
	<b>VRF Air Conditioning Systems (Toshiba)</b> <i>-VRF Equipment, Condenser, FCU, -Refrigeration selector boxes, Controls</i>	23 81 49
	<b>Unit Heaters</b> <i>-Electric UH, Gas UH, Flue piping</i>	23 82 39
	<b>Humidity Control Equipment</b> <i>-Product Details. See Spec for more details</i>	23 84 00
	<b>Vehicle Exhaust System</b> <i>-Equipment submittal</i>	23 35 16
	<b>Integrated Automation of Facility Equipment</b> <i>-Product Data, Shop Drawings</i>	25 51 00
	<b>Integrated Automation of Fire Suppression</b> <i>-Product Data, Shop Drawings</i>	25 53 00
	<b>Integrated Automation Sequence of Facility</b> <i>-Product Data, Shop Drawings</i>	25 91 00
	<b>Integrated Automation Sequence of Fire Supp.</b> <i>-Product Data, Shop Drawings</i>	25 93 00

**SECTION 23 05 00 - COMMON WORK RESULTS FOR HVAC**

**PART 1 - GENERAL**

**1.1 RELATED DOCUMENTS**

- A. The Drawings and General Provisions of the Contract, including General and Supplementary Conditions and Division 01 Specification Sections, apply to the Work in this Section.

**1.2 DESCRIPTION**

- A. The General Requirements for Mechanical Work are intended to be complementary to the General Requirements of the Construction Contract.
- B. Work Included: Provide complete mechanical systems where shown on the drawings, as specified herein, and as needed for a complete and proper installation including, but not necessarily limited to the following summary of work:
  - 1. Furnish and install a complete existing/revised DDC system as shown on drawings and described herein.
  - 2. Other items and services required to complete the systems.

**1.3 GENERAL REQUIREMENTS**

- A. Unless otherwise specified, materials are to be new and of current U.S. manufacture, free from defects and of the best quality of their respective kinds.
- B. Equipment and/or materials damaged in shipment or handling, or otherwise damaged before installation, shall be replaced with new equipment and/or materials. Damaged equipment and/or materials shall not be repaired at the jobsite.
- C. Furnishing of the proper equipment and/or materials and to see that it is installed as recommended by the manufacturer is entirely the responsibility of the Contractor. If required for proper installation, the Contractor shall obtain advice and supervisory assistance from a representative of the specific manufacturer of the equipment being installed.
- D. Materials and adhesives to conform to Federal Standard Flame-Spread Properties, Inc., with composite fire and smoke hazard ratings, maximum 25 for flame spread and 50 for smoke developed. Adhesives to be waterproof.
- E. The Contractor shall promptly notify the Architect in writing of any conflict between the requirements of the Contract Documents and the manufacturer's directions and shall obtain the Architect instructions before proceeding with the work. Should the Contractor perform any such work that does not comply with the manufacturer's directions or such instructions from the Architect, he shall bear all costs arising in connection with the deficiencies.

**1.4 QUALITY ASSURANCE AND APPLICABLE STANDARDS**

- A. Use adequate numbers of skilled workers that are thoroughly trained and experienced in the necessary crafts and are completely familiar with the specified requirements and the

methods needed for proper performance of the work of this Section.

- B. The Contractor shall be responsible for fitting his material and apparatus into the building and shall carefully lay out his work at the site to conform to the existing structural conditions, to avoid all obstructions, to conform to the details of the installation and thereby to provide an integrated satisfactory operating installation.
- C. Without additional cost to the Owner, provide such other labor and materials as are required to complete the work of this Section in accordance with the requirements of governmental agencies having jurisdiction, regardless of whether such materials and associated labor are called for elsewhere in these Contract Documents.
- D. Codes: Perform all work in accordance with the latest edition of the following codes:
  - 1. State and city building, fire, plumbing and mechanical codes.
  - 2. International Fire Code
  - 3. Uniform Mechanical Code
  - 4. Uniform Plumbing Code
  - 5. National Electrical Code
  - 6. Energy Conservation Code
  - 7. National Fire Protection Association (NFPA)
  - 8. American with Disabilities Act (ADA)
  - 9. ICC/ANSI A117.1 Accessible and Useable Buildings and Facilities.
  - 10. All authorities having jurisdiction.
  - 11. Architectural code review drawing.
- E. The Contractor shall comply in every respect with all requirements of National Fire Protection Association and local Fire Department regulations. In no case does this relieve the Contractor of the responsibility of complying with these Specifications and Drawings where specified conditions are of higher quality than the requirements of the above-specified authorities. Where requirements of the Specifications and Drawings are more lenient than the requirements of the above authorities having jurisdiction, the Contractor shall make installations in compliance with the requirements of the above authorities with no extra compensation.
- F. Where conflicts occur between drawings, specifications or code requirements, the most stringent requirement shall take precedence.
- G. Standards: The specifications and standards of the following organizations are by reference made a part of these specifications. All work, unless otherwise indicated, shall comply with the requirements and recommendations wherever applicable:
  - 1. American National Standards Institute (ANSI).
  - 2. Air Conditioning and Refrigeration Institute (ARI).
  - 3. American Society for Testing and Materials (ASTM).
  - 4. American Society of Mechanical Engineers (ASME).
  - 5. American Society of Refrigeration, Heating and Air Conditioning Engineers (ASHRAE).
  - 6. Electrical Testing Laboratories (ETL).
  - 7. National Bureau of Standards (NBS).
  - 8. National Electrical Manufacturer's Association (NEMA).
  - 9. National Fire Protection Association (NFPA).
  - 10. Underwriters Laboratories, Inc. (UL).

#### 1.5 REQUIREMENTS OF REGULATORY AGENCIES

- A. The requirements and recommendations of the latest edition of the Occupational Safety

and Health Administration (OSHA) Act are by reference made a part of these specifications. All work shall comply with the requirements and recommendations wherever applicable.

1.6 SUBMITTALS

- A. Comply with all submittal provisions of Division 1.
- B. Submit electronic copies of the submittal to the prime consultant (i.e. architect) in order to process and track the submittals properly in accordance with Division 1 and 23 submittal requirements. Architects and consultants are to submit all submittals and RFI's to the mechanical engineer electronically. Send to "**mdengca@md-eng.com**". Submittals shall be labeled by their project specification section or CSI specification section if not listed in project specifications
- C. Product Data: Submit the following:
  - 1. Materials list of items proposed to be provided under Division 23.
  - 2. Manufacturer's specifications and other data needed to prove compliance with the specified requirements. The term "Compliance" is understood to mean that the Contractor certifies that the submitted equipment will meet or exceed the contract document requirements. Items that do not clearly meet this definition should be identified and explained as required in the following paragraph.
  - 3. Identify the difference between the specified item or function and the proposed. Explain with enough detail so that the Engineer/Owner can easily determine that the item complies with the functional intent. List any disadvantages or advantages of the proposed item versus the specified item. Submit technical data sheets and/or pictures and diagrams to support and clarify. Organize in a clear and concise format. All substitutions shall be approved in writing by Architect. The Engineer's decision shall be final.
  - 4. Allow a minimum of ten (10) working days for the review of submittals and each re-submittal.
  - 5. Submittals that have been reviewed and marked as REJECTED (REJ) or MAKE CORRECTIONS NOTED (MCN) should be resubmitted within 10 days to be reviewed again by engineer.
  - 6. Compliance with the Contract documents shall be the sole responsibility of the Contractor. Items on equipment that are were not accepted by the Engineer in writing as an approved equal shall be replaced or revised to comply with the contract documents at the Contractor's expense.
  - 7. Manufacturer's recommended installation procedures which, when reviewed by the Engineer, shall become the basis for accepting or rejecting actual installation procedures used on the work.
  - 8. Sign the submittal as an indication of compliance with the contract documents. Any deviations from the contract documents shall be indicated on the submittal prior to signing. Any deviations not indicated shall be cause for rejection and removal of the non-complying equipment at the Contractor's expense.
- D. Submittals required of materials and equipment under this section include the following:
  - 1. DDC Direct Digital Controls Equipment:
    - a. **Provide clearly marked-up** manufacturer's data showing compliance with scheduled values and specifications for: **(Include model numbers and highlight products)**
      - 1) DDC controllers.
      - 2) DDC wiring diagrams.
      - 3) DDC actuators and operators.

- b. Provide all electrical characteristics.
  2. Record Documents: Reference the requirements detailed in this section.
  3. Operation and Maintenance Data: Reference the requirements detailed in this section.
- E. Resubmission of rejected submittals shall be limited to one (1) in number. Costs for processing subsequent resubmittals in excess of the first resubmittal, resulting from the Contractor's disregard of Engineer's primary submittal rejection comments, shall be borne by the Contractor. Costs shall be based on Engineer's hourly rates as published in their current professional fee schedules and shall also include reimbursable costs for delivery, mailing, and photocopies at direct cost plus ten percent (10%).

## 1.7 SUBSTITUTIONS

- A. Comply with all provisions of Division 1.
- B. The use of manufacturers' names and catalog numbers followed by the phrase "or equal" is generally used to establish a standard of quality and utility for the specified items and to provide a dimensional reference for construction documents that are drawn to scale.
- C. Submittals for "equal" items shall, where applicable, include the following data that are not necessarily required for specified items:
  1. Performance characteristics.
  2. Materials.
  3. Finish.
  4. Certification of conformance with specified codes and standards.
  5. Manufacturer's specifications and other data needed to prove compliance with the specified requirements. The term "Compliance" is understood to mean that the Contractor certifies that the submitted equipment will meet or exceed the contract document requirements. Items that do not clearly meet this definition should be identified and explained as required in Paragraph 6 below.
  6. Identify the difference between the specified item or function and the proposed. Explain with enough detail so that the Engineer/Owner can easily determine that the item complies with the functional intent. List any disadvantages or advantages of the proposed item versus the specified item. Submit technical data sheets and/or pictures and diagrams to support and clarify. Include shop drawings for all piping and ductwork equipment per Paragraph 1.5 Submittals. Organize in a clear and concise format.
- D. Submittals of "equal" components or systems may be rejected if:
  1. The material or equipment would necessitate the alteration of any portion of the mechanical, or electrical design.
  2. Dimensions vary from the specified material or equipment in such a manner that accessibility or clearances are impaired or the work of other trades is adversely affected.
- E. Proposed substitutions for materials or equipment must be submitted seven (7) days prior to final bid date for consideration as approved equals. Otherwise, such substitutions will not be permitted. Proposals for substitutions shall be made only by the prime bidders. Manufacturers, distributors, and sub-contractors shall not make proposals to the Engineer for substitutions.
- F. All equipment installed on this project shall have local representation, local factory authorized service, and a local stock of repair parts

- G. No substitution shall be made unless authorized in writing by the Engineer. Should a substitution be accepted, and should the substitute material prove defective or otherwise unsatisfactory for the service intended, and within the guarantee period, the Contractor shall replace this material or equipment with material or equipment specified, at his own expense, and to the satisfaction of the Engineer.
- H. Contractors submitting bids on substitute materials and equipment must also provide a written performance guarantee certifying that the substitute materials and equipment will produce the specified effects and meet the approval of the Engineer.

**1.8 ORDINANCES, PERMITS, AND ROYALTIES**

- A. Procure all permits and licenses necessary for completion of this project and pay all lawful fees required and necessary pursuant in obtaining said permits and licenses. All required certificates of approvals and inspections by local governing and regulating authorities shall be obtained and paid for by the Contractor.
- C. Pay any royalty payments required or fees for the use of patented equipment or systems. Defend all law suits or claims for infringement of any patent rights and shall hold the Owner and/or Engineer harmless from loss as a result of said suits or claims.

**1.9 COMPATIBILITY OF EQUIPMENT**

- A. Assume full responsibility for satisfactory operation of all component parts of the mechanical systems to assure compatibility of all equipment and performance of the integrated systems in accordance with the requirements of the specifications. Should the Contractor consider any part of the specifications or drawings as rendering his acceptance of such responsibility impossible, prohibitive, or restrictive, he shall notify the Engineer before submitting his bid, and the bid shall be accompanied by a written statement of any objections or exceptions to the specifications and drawings.
- B. The size of mechanical and electrical equipment indicated on the Drawings is based on the dimensions of a particular manufacturer. While other manufacturers may be acceptable, it is the responsibility of the Contractor to determine if the equipment he proposes to furnish will fit in the space. Fabrication Drawings shall be prepared when required by the Engineer or Owner to indicate a suitable arrangement.
- C. All equipment shall be installed in a manner to permit access to all surfaces. All valves, motors, drives, filters, and other accessory items shall be installed in a position to allow removal for service without disassembly of another part.

**1.10 CONSTRUCTION REQUIREMENTS**

- A. The drawings show the arrangements of work. Should project conditions necessitate rearrangement, or if the materials or equipment can be installed to a better advantage in a different manner, the Contractor shall, before proceeding with the work, prepare and submit five copies of Drawings of the proposed arrangement for the Engineer's review. Allow a minimum of ten (10) working days for review.
- B. Should the Contractor propose to install equipment requiring space conditions other than those shown, or rearrange the equipment, he shall assume responsibility for the rearrangement of the space and shall have the Engineer review the change before proceeding with the work. The request for such changes shall be accompanied by shop drawings of the space in question. Identify monetary credits proposed or other benefits of the change. Allow a minimum of ten (10) working days for review.

**1.11 PROJECT RECORD DOCUMENTS**

- A. Provide the record documents associated with the work of Division 23 in strict accordance with the provisions of these specifications.
- B. Throughout progress of the Division 23 Work, maintain an accurate record of changes in the Contract Documents that apply to work of Division 23. Changes shall include all addendums issued during bidding.
- C. Delegate the responsibility for maintenance of Record Documents to one person on the Contractor's staff as approved by the Engineer.
- D. Accuracy of Records
  - 1. Thoroughly coordinate changes within the Record Documents, making adequate and proper entries on each page of Specifications and each sheet of drawings and other documents where such entry is required to show the change properly. Match the symbology and format of the base documents.
  - 2. Accuracy of records shall be such that a future verification of items shown in the Contract Documents may rely reasonably on information obtained from the approved Project Record Documents.
- E. Maintain the job set of Record Documents completely protected from deterioration and from loss and damage until completion of the work and transfer of all recorded data to the final Project Record Documents.
- F. Making Entries on Drawings
  - 1. Using an erasable colored pencil (not ink or indelible pencil), clearly describe the change by graphic line and note as required.
  - 2. Date all entries.
  - 3. Call attention to the entry by a "cloud" drawn around the area or areas affected.
  - 4. In the event of overlapping changes, use different colors for the overlapping changes.
  - 5. Make entries within 24 hours after receipt of information that the change has occurred.
  - 6. Maintain the base drawing format and use the same symbology.
  - 7. Convert field mark-ups to finished CADD record drawings when required in this section.
- G. Conversion of Schematic Layouts
  - 1. In some cases on the drawings, items are shown schematically and are not intended to portray precise physical layout. Determine final physical arrangement subject to the Engineer's approval. However, design of future modifications of the facility may require accurate information as to the final physical layout of items which are shown only schematically on the drawings.
  - 2. Show on the job set of record drawings, by dimension accurate to within one inch, the centerline of each run of items such as all sleeves and piping, etc., below grade, in walls, or in the concrete slab. A surface mounted device indicates the exact location:
    - a. Clearly identify the item by accurate note.
    - b. Show, by symbol or note, the vertical location of the item "under slab," "in ceiling plenum," "exposed," and the like.
    - c. Make all identification sufficiently descriptive that it may be related reliably to the specifications.



- H. Final Project Record Documents
1. The purpose of the final Project Record Documents is to provide factual information regarding all aspects of the Work, both concealed and visible, to enable future modification of the Work to proceed without lengthy and expensive site measurement, investigation, and examination.
  2. Provide CAD electronic files in .dwg format using AutoCAD software. Upon written request, completion of a release form, and payment of the Engineer's standard fee of \$200 plus applicable sales tax for a set-up charge and \$50 per drawing plus applicable sales tax for copies of such files, Engineer will provide AutoCAD electronic files of base Contract Drawings in dwg format on compact discs. Engineer will also provide a list of drawing layers and names that shall be maintained.
  3. Provide completed record drawings on CD-R and one full size hard copy of each drawing.
  4. Refer to Division 1 for additional requirements.

1.12 OPERATION AND MAINTENANCE DATA

- A. Submit two copies of a preliminary draft of the proposed manual or manuals to the Engineer for review and comments. Allow a minimum of ten (10) working days for review.
- B. Submit specified number copies of the approved manual to the Engineer prior to indoctrination of operation and maintenance personnel.

- C. Prepare in accordance with the following standards:

Format:

Size: 8½" x 11"

Paper: White bond, at least 20 lb. weight

Text: Neatly written or printed

Drawings: 11" in height preferable; bind in with text; foldout acceptable; larger drawings acceptable but fold to fit within the Manual and provide a drawing pocket inside rear cover or bind in with text.

Flysheets: Separate each section of the Manual with neatly prepared flysheets briefly describing contents of the ensuing section; flysheets may be in color.

Binding: Use heavy-duty plastic or fiber-board covers with binding mechanism concealed inside the manual; 3-ring binders will be acceptable; all binding is subject to the Architect's approval.

Measurements: Provide all measurements in U.S. standard units such as feet-and-inches, lbs, and cfm. Where items may be expected to be measured within ten years in accordance with metric formulae, provide additional measurements in the "International System of Units" (SI).

- D. Provide front and back covers for each manual, using durable material approved by the Architect, and clearly identified on or through the cover with at least the following information:

**OPERATING AND MAINTENANCE INSTRUCTIONS**

- Title Page
  - Job Name
  - Site Address
  - Include Contact information of prime contractor.
- Table of contents
- Warranty Information.
  - Include all contractor warranties
    - Signed and dated documents
- Permits-Inspections
- Subcontractor list
  - Include all subcontractors.
    - Company name, Contact info.
    - Trade Responsibility.
- Vendor list
  - Include name and addresses of vendors
    - Warranty information
    - Replaceable parts
- Approved submittals
  - Include all approved product submittals
- Reports/Certificates/Redlines
  - Engineers Observation Reports
  - Contractor Start-up Report
  - As-builts for DDC Diagrams
- O&M Manuals
- Equipment Information.
  - Include Model, Serial and location.
- Signed Approval
  - Page for approval signature of the engineer and approval date.

**OPERATING AND MAINTENANCE MANUAL (Required Layout**

- E. Contents: Include at least the following:
1. Neatly typewritten index near the front of the manual, giving immediate information as to location within the manual of all emergency information regarding the installation.
  2. Complete instructions regarding operation and maintenance of all equipment provided including lubrication, disassembly, and reassembly.

3. Complete nomenclature of all parts of all equipment.
4. Complete nomenclature and part number of all replaceable parts, name and address of nearest vendor, and all other data pertinent to procurement procedures.
5. Copy of all guarantees and warranties issued.
6. Manufacturer's bulletins, drawings, and descriptive data, clearly indicating the precise items included in this installation and deleting, or otherwise clearly indicating, all manufacturers' data with which this installation is not concerned.
7. Such other data as required in other sections of these specifications.

#### 1.13 WARRANTY

- A. Contractor shall warranty all equipment and workmanship for a period of one year after date of substantial completion and replace or repair any faulty equipment or installation at no cost to the Owner for such service during this period, all in accordance with requirements of Division 1.
- B. This warranty shall not void specific warranties issued by manufacturers for greater periods of time. Nor shall it void any rights guaranteed to the Owner by law.
- C. Warranties shall be in writing in a form satisfactory to the Owner, and shall be delivered to the Owner before final payment is made.
- D. Upon completion of the work of Division 23, thoroughly clean all exposed portions of the mechanical installation, removing all traces of soil, labels, grease, oil and other foreign material and using only the type cleaner recommended by the manufacturer of the item being cleaned.

## PART 2 - PRODUCTS

## PART 3 - EXECUTION

### 3.1 TESTING AND INSPECTION

- A. Provide personnel and equipment, make required tests, and secure required approvals from the Engineer and governmental agencies having jurisdiction.
- B. Make written notice to the Architect adequately in advance of each of the following stages of construction:
  1. When all rough-in is complete, but not covered.
  2. As specified in all Division 23 sections.
  3. At the completion of the work of Division 23.
- C. When material or workmanship is found to not comply with the specified requirements, remove the noncomplying items from the job site and replace them with items complying with the specified requirements at no additional cost to the Owner. This shall be performed within 3 days after receipt of written notice of noncompliance.

### 3.2 DEMOLITION AND RELOCATION

- A. The Contractor shall modify, remove, and/or relocate all materials and items so indicated on the Drawings or required by the installation of new facilities. All removals and/or dismantling shall be conducted in a manner as to produce maximum salvage. Salvage materials shall

remain the property of the Owner, and shall be delivered to such destination or otherwise disposed of as directed by the Owner. Materials and/or items scheduled for relocation and which are damaged during dismantling or reassembly operations shall be repaired and restored to good operative condition. The Contractor may, at his discretion, and upon the approval of the Owner, substitute new materials and/or items of like design and quality in lieu of materials and/or items to be relocated.

- B. All items which are to be relocated shall be carefully removed in reverse to original assembly or placement and protected until relocated. The Contractor shall clean and repair and provide all new materials, fittings, and appurtenances required to complete the relocations and to restore to good operative order. All relocations shall be performed by workmen skilled in the work and in accordance with standard practice of the trades involved.
- C. When items scheduled for relocation and/or reuse are found to be in damaged condition before work has been started on dismantling, the Contractor shall call the attention of the Owner to such items and receive further instructions before removal. Items damaged in repositioning operations are the Contractor's responsibility and shall be repaired or replaced by the Contractor as approved by the Owner, at no additional cost to the Owner.
- D. Service lines and wiring to items to be removed, salvaged, or relocated shall be removed to points indicated on the Drawings, specified, or acceptable to the Owner. Service lines and wiring not scheduled for reuse shall be removed to the points at which reuse is to be continued or service is to remain. Such services shall be sealed, capped, or otherwise tied-off or disconnected in a safe manner acceptable to the Owner. All disconnections or connections into the existing facilities shall be done in such a manner as to result in minimum interruption of services to adjacent occupied areas. Services to existing areas or facilities which must remain in operation during the construction period shall not be interrupted without prior specific approval of the Owner as hereinbefore specified.

### 3.3 JOBSITE CONDITIONS

- A. Examine the areas and conditions under which work of this Section will be performed. Include required work to correct conditions detrimental to the timely and proper completion of all Division 21 Work. Do not proceed until unsatisfactory conditions are corrected.
- B. The Contractor shall at all times take such precautions as may be necessary to properly protect all materials and equipment from damage from the time of delivery until the completion of the work. This shall include the erection of all required temporary shelters and supports to adequately protect any items stored in the open on the site from the weather, the ground and surrounding work; the cribbing of any items above the floor of the construction; and the covering of items in the incomplete building with tarpaulins or other protective covering; the installation of electric heaters in electrical switchgear and similar equipment to prevent moisture damage. Failure on the part of the Contractor to comply with the above will be sufficient cause for the rejection of the items in question.
- C. Take particular care not to damage the building structure in performing work. All finished floors, step treads, and finished surfaces shall be covered to prevent any damage by workmen or their tools and equipment during the construction of the building.
- D. Equipment and materials shall be protected from rust both before and after installation. Any equipment or materials found in a rusty condition at the time of final inspection must be cleaned of rust and repainted as specified elsewhere in these Specifications.

**3.4 STORAGE AND PROTECTION**

- A. Contractor shall provide the required protection of equipment and materials from the time of delivery until the completion of the Work. Protect from damage, rust, rain, humidity and dust.
- B. Do not receive equipment or materials on the jobsite until adequate space has been provided for storage.
- C. Provide adequate supports for protection from the ground and erect required shelters for items stored in the open.
- D. Items stored within the building are to be adequately protected and covered with tarpaulins or other protective covering.
- E. Protect the building at all times during construction from damage by workmen, their tools and/or equipment. Protect floors, steps, wall, ceilings, doors, windows and other finish surfaces.
- F. Equipment and materials found in a rusty condition at completion of the work will be thoroughly cleaned of rust and refinished as required to its original condition.

**3.5 PREPARATION AND COORDINATION**

- A. Perform coordination work in strict accordance with provisions of these specifications and the following:
  - 1. Coordinate as necessary with other trades to assure proper and adequate interface with all work.
  - 2. Although such work is not specifically indicated, furnish and install all supplementary or miscellaneous items, appurtenances and devices incidental to or necessary for a sound, secure and complete installation of the fire suppression system.
  - 3. Coordinate accepted equipment changes from those scheduled or specified with other trades affected. Additional compensation to other trades for equipment changes is the responsibility of the Contractor making the change.
- B. The Mechanical, Electrical, and associated Drawings are necessarily diagrammatic by their nature, and are not intended to show every connection in detail or every pipe or conduit in its exact location. These details are subject to the requirements of standards referenced elsewhere in these specifications, and structural and architectural conditions. The Contractor shall carefully investigate structural and finish conditions and shall coordinate the separate trades in order to avoid interference between the various phases of work. Work shall be organized and laid out so that it will be concealed in furred chases and suspended ceilings, etc., in finished portions of the building, unless specifically noted to be exposed. All exposed work shall be installed parallel or perpendicular to the lines of the building unless otherwise noted.
- C. When the mechanical and electrical Drawings do not give exact details as to the elevation of conduit, the Contractor shall physically arrange the systems to fit in the space available at the elevations intended with proper grades for the functioning of the system involved. Exposed conduit systems are generally intended to be installed true and square to the building construction, and located as high as possible against the structure in a neat and workmanlike manner. The Drawings do not show all required offsets, control lines, pilot lines and other location details. Work shall be concealed in all

finished areas.

- D. Verify all dimensions and distances. No additional compensation will be allowed because of differences between work shown on the Drawings and actual dimensions and distances at the jobsite.

**END OF SECTION**

THIS PAGE INTENTIONALLY LEFT BLANK

**SECTION 23 05 29 - PIPE HANGERS AND SUPPORTS FOR HVAC PIPING AND EQUIPMENT**

PART 1 - GENERAL

1.1 RELATED DOCUMENTS

- A. The Drawings and General Provisions of the Contract, including General and Supplementary Conditions and Division 01 Specification Sections, apply to the Work in this Section

1.2 SUMMARY

- A. Provide all equipment, materials, labor, supervision, and services necessary for or incidental to the installation of all necessary identification items as indicated on the drawings and as specified.
- B. Work included:
  - 1. Pipe hangers and supports.
  - 2. Concrete supports for equipment.
  - 3. Sleeving for mechanical equipment.
- C. Submittals: Provide submittals as required in Section 23 0500 "Common Work Results for HVAC".

1.3 QUALITY ASSURANCE

- A. Use adequate numbers of skilled workmen who are thoroughly trained and experienced in the necessary crafts and who are completely familiar with the specified requirements and the methods needed for proper performance of the work of this Section.
- B. Without additional cost to the Owner, provide such other labor and materials as are required to complete the work of this Section in accordance with the requirements of governmental agencies having jurisdiction, regardless of whether such materials and associated labor are called for elsewhere in these Contract Documents.

1.4 REFERENCE STANDARDS

- A. Automatic Sprinkler Pipe Supports: NFPA 13, Standard for the Installation of Sprinkler Systems.
- B. Standpipe System Supports: NFPA 14, Standard for the Installation of Standpipe and Hose Systems.

1.5 SUBMITTALS:

- A. **Provide submittals as required in Section 23 00 10, "Submittal Proess".**

**PART 2 - PRODUCTS**

**2.1 PIPE HANGERS AND SUPPORTS**

- A. Supports, hangers, anchors, guides and supplementary steel shall be provided for horizontal and vertical piping and shall meet or exceed the ASA Code for Pressure Piping.
- B. Rod sizes noted are minimum sizes. The structural integrity of the supports is the responsibility of the Contractor.
- C. Hangers Supporting and Contacting Brass or Copper:
  - 1. 3" and Smaller: Grinnell Fig. CT-109, copper plated, split-ring hanger with adjusters.
  - 2. 4" and Larger: Grinnell Fig. CT-65, copper plated, clevis hanger with 2 nuts each rod.
  - 3. Isolate copper or brass from ferrous metals with an approved dielectric material.
- D. Hangers Supporting Insulated Lines:
  - 1. Outside Diameter of Insulation 6" or Smaller and all Ferrous Pipe 3" Diameter and Smaller: Grinnell Fig. 108, malleable iron, split type with adjustable swivel and locknut.
  - 2. Outside Diameter of Insulation 7" and Larger and all Ferrous Pipe Larger than 3" Diameter: Grinnell Fig. 260, malleable iron, clevis hanger with two nuts on each support.
- E. Protection Shields for Hangers:
  - 1. Galvanized metal shields shall encircle the lower half of the insulation.
  - 2. Provide shields at hangers on dual and low temperature pipes on trapeze type hangers.
  - 3. Provide rigid insulation at all shields and hangers, extending a minimum of 6" each side of hanger.
  - 4. Shield gauges shall be as follows:

<u>Insulation Diameter</u>	<u>U.S.S. Gauge (Galvanized)</u>
Up to 3"	22
3" thru 6"	16
Above 6"	12
- F. Supports for Vertical Riser Piping:
  - 1. Provide Grinnell Fig. 261 double bolt riser clamps at each floor. Bear on structure.
  - 2. At 8 feet o.c., 2-hole rigid clamps. Kindorf channels and C-105 straps. Support from vertical surfaces.
  - 3. Brass or copper pipe shall be isolated from support with sheet polyethylene, minimum 1/8" thick.
- G. Supports for Vertical and Horizontal Piping in Chases and Partitions:
  - 1. Provide securely anchored supports for pipes serving plumbing fixtures and equipment near the area the pipe penetrates the wall.
  - 2. Supports shall be steel plate, angles or unistruts mounted vertically or horizontally with unistrut clamps P2426, P2008 or P1109.
  - 3. Attach supports to wall or floor construction with clip angles, brackets or other approved anchoring devices.



- 4. Brass and copper pipe shall be isolated from support with sheet polyethylene, minimum 1/8" thick.

**2.2 INSERTS**

- A. Provide inserts at each hanger as required for concrete support. Avoid interference with concrete reinforcing.
- B. Inserts to be malleable iron case of galvanized steel shell and expander plug for threaded connection with lateral adjustment, top slot for reinforcing rods, and lugs for attaching to forms.
- C. Provide reinforcing as required to support load.
- D. Size inserts to suit threaded hanger rods.

**2.3 HANGER RODS**

- A. Provide steel hanger rods, threaded both ends, threaded one end or continuous threaded.
- B. Size hanger rods as follows:

<u>Pipe Size</u>	<u>Rod Diameter</u>
4" & Smaller	3/8"
5" thru 8"	1/2"
10" & 12"	5/8"
14" & 16"	3/4"

**2.4 SLEEVES**

- A. Provide sleeves where pipes penetrate floors, walls, foundations, fireproofing, etc.
- B. Size sleeves large enough to allow for movement due to expansion and to provide for continuous movement. Provide a bead of sealant in space between pipe and sleeve. Use link-seal to seal between pipe and sleeve for all slab on grade floor penetrations.
- C. Use Schedule 40 galvanized steel pipe sleeves for all floor and foundation penetrations. Sleeves shall extend minimum of 2" above finished floor and flush with vertical wall surface.

**2.5 TRAPEZES**

- A. Trapezes of Kindorf, Elcen or approved equal may be provided where multiple lines run horizontally at the same elevation.

**2.6 CONCRETE SUPPORTS FOR EQUIPMENT**

- A. Provide concrete pad foundations for the support of equipment such as floor-mounted pumps, air handling units, fans, etc.
- B. Unless otherwise noted, concrete pads shall be constructed of not less than 3,000 lb. concrete and not less than 4" high and shall extend on all sides a minimum of 8

inches beyond the limits of the mounted equipment. Pads shall be poured in forms built of new-dressed lumber. All corners of the foundations shall be neatly chamfered 3/4" wide by means of sheet metal or triangular wood strips nailed to the form. Reinforce with No. 4 rebar 6" on center.

- C. Foundation bolts, 3/4" round-hooked, shall be placed in the forms when the concrete is poured, the bolts being correctly located by means of templates. Each bolt shall be set in a sleeve of size to provide 1/2" clearance around bolt. Allow 1" below the equipment bases for alignment and grouting. After grouting, the forms shall be removed and the surface of the foundations shall be hand rubbed with carborundum.
- D. Foundation pads for equipment located on the exterior of the building shall be provided as indicated.
- E. Submit shop drawings of concrete pads for review by the Architect.

## 2.7 STRAP HANGERS

- A. Under no circumstances will perforated strap iron or wire be acceptable for hangers on this project.

## PART 3 - EXECUTION

### 3.1 INSTALLATION OF SUPPORTS

- A. All pipe supports shall be designed and installed to avoid interferences with other piping, hangers, ducts, electrical conduit, supports, building structure, equipment, etc. All piping shall be installed with due regard to expansion and contraction. The type of hanger, method of support, location of support, etc., shall be governed in part by this specification.
- B. Pipe hangers shall be attached to the structure as follows:
  - 1. Poured-in-Place Concrete: Each hanger rod shall be fitted with a nut at its upper end, which nut shall be set into an Underwriters' Laboratories, Inc., listed universal concrete insert placed in the formwork before concrete is poured.
  - 2. Steel Bar Joists: Where pipes and loads are supported under bar joists, hanger rods shall be run through the space between the bottom angles and secured with a washer and two nuts. Where larger lines are supported beneath bar joists, hanger rods shall be secured to angle irons of adequate size. Each angle shall span across two or more joists as required to distribute the weight properly and shall be welded to the joists or otherwise permanently affixed thereto.
  - 3. Steel Beams: Pipes and loads supported under steel beams shall be installed using approved beam clamps.

### 3.2 SPACING

- A. Install hangers for steel piping with the following maximum spacing and minimum rod sizes according to MSS SP 69 Tables 3 and 4:
  - 1. NPS 3/4: Maximum span, 7 feet; minimum rod size, 3/8 inch.
  - 2. NPS 1: Maximum span, 7 feet; minimum rod size, 3/8 inch.
  - 3. NPS 1-1/4: Maximum span, 7 feet; minimum rod size, 3/8 inch.

4. NPS 1-1/2: Maximum span, 9 feet; minimum rod size, 3/8 inch.
  5. NPS 2: Maximum span, 10 feet; minimum rod size, 3/8 inch.
  6. NPS 2-1/2: Maximum span, 11 feet; minimum rod size, 1/2 inch.
  7. NPS 3: Maximum span, 12 feet; minimum rod size, 1/2 inch.
  8. NPS 3-1/2: Maximum span, 13 feet; minimum rod size, 1/2 inch.
  9. NPS 4: Maximum span, 14 feet; minimum rod size, 5/8 inch.
  10. NPS 5: Maximum span, 16 feet; minimum rod size, 5/8 inch.
  11. NPS 6: Maximum span, 17 feet; minimum rod size, 3/4 inch.
  12. NPS 8: Maximum span, 19 feet; minimum rod size, 3/4 inch.
  13. NPS 10: Maximum span, 22 feet; minimum rod size, 7/8 inch.
  14. NPS 12: Maximum span, 23 feet; minimum rod size, 7/8 inch.
  15. NPS 14: Maximum span, 25 feet; minimum rod size, 1 inch.
  16. NPS 16: Maximum span, 27 feet; minimum rod size, 1 inch.
  17. NPS 18: Maximum span, 28 feet; minimum rod size, 1 inch.
  18. NPS 20: Maximum span, 30 feet; minimum rod size, 1-1/4 inches.
- B. Install hangers for copper tubing with the following maximum spacing and minimum rod sizes:
1. NPS 1/2: Maximum span, 5 feet; minimum rod size, 3/8 inch.
  2. NPS 5/8: Maximum span, 5 feet; minimum rod size, 3/8 inch.
  3. NPS 1: Maximum span, 6 feet; minimum rod size, 3/8 inch.
  4. NPS 1-1/4: Maximum span, 8 feet; minimum rod size, 3/8 inch.
  5. NPS 1-1/2: Maximum span, 8 feet; minimum rod size, 3/8 inch.
  6. NPS 2: Maximum span, 8 feet; minimum rod size, 3/8 inch.
  7. NPS 2-1/2: Maximum span, 9 feet; minimum rod size, 3/8 inch.
  8. NPS 3: Maximum span, 10 feet; minimum rod size, 3/8 inch.
  9. NPS 4: Maximum span, 12 feet; minimum rod size, 1/2 inch.
- C. Spacing and rod sizes for other piping materials shall be as recommended by the manufacturer.

### 3.3 TRAPEZES

- A. Trapeze members, including suspension rods, shall be properly sized for the number, size and loaded weight of the lines they are to support. Install as noted above.

### 3.4 HANGERS AND SUPPORTS

- A. All hangers and supports for fire standpipe systems and fire sprinkler systems shall be Underwriters' Laboratories, Inc. approved types.

### 3.5 EQUIPMENT FOUNDATIONS

- A. Provide equipment foundations associated with the work in accordance with the provisions of these specifications.
- B. Provide concrete bases for all pad or floor mounted equipment.

### 3.6 MISCELLANEOUS

- A. Install any other special foundations, hangers and supports indicated on the drawings, specified elsewhere, or required by installation conditions.

**END OF SECTION**

THIS PAGE INTENTIONALLY LEFT BLANK

**SECTION 23 0548 - VIBRATION AND SEISMIC CONTROLS FOR HVAC PIPING AND EQUIPMENT**

**PART 1 - GENERAL**

**1.1 RELATED DOCUMENTS**

- A. The Drawings and General Provisions of the Contract, including General and Supplementary Conditions and Division 01 Specification Sections, apply to the Work in this Section.

**1.2 SUMMARY**

- A. The extent of vibration isolation work is indicated by drawings and schedules, and by the requirements of this section.
- B. The types of vibration isolation work specified in this section include the following:
  - 1. Support isolation for motor-driven mechanical equipment.
  - 2. Isolation including support isolation for piping risers.
  - 3. Support isolation of piping.
  - 4. Flexible connections for piping at equipment.
- C. Refer to other sections of these specifications for equipment foundations, hangers, sealants, gaskets, flexible connections for piping, and other work related to vibration isolation work.

**1.3 QUALITY ASSURANCE**

- A. Product Qualification: Provide each type of vibration isolation unit produced by a specialized manufacturer, with not less than 5 years' successful experience in the production of units similar to those for the project.
  - 1. Except as otherwise indicated obtain support isolation units from a single manufacturer.
  - 2. Engage the manufacturer to provide technical supervision of the installation of support isolation units produced by him, and of associated inertia bases (if any).
- B. Manufacturer: Acceptable vibration isolation support unit manufacturers are as follows:
  - 1. Mason Industries, Inc.
  - 2. Vibration Mountings and Controls, Inc.
  - 3. Amber Booth
  - 4. Peabody Kinetics
- C. Manufacturer Certification: Where vibration isolation support units are indicated for a minimum static deflection, provide manufacturer's certification that units have been tested and comply with the indicated requirements.
- D. All items of equipment, whether suspended, floor mounted or otherwise supported, which are capable of producing vibration, shall be installed with vibration isolation. The isolation shall prevent the transmission of objectionable noise or vibration to the building structure.

- E. Submit for approval data showing disturbing frequency, supported weight, static deflection or natural frequency, and calculations supporting same for each isolator.

#### 1.4 SUBMITTALS

- A. Manufacturer's Data, Vibration Isolation:
  - 1. **Provide submittals as required in Section 23 00 10, "Submittal Process".**
  - 2. For information, submit manufacturer's specifications, detailed drawings, performance characteristics data and installation instructions for each type of unit required.
  - 3. Include data for each type and size of unit, showing isolation efficiency, stiffness, natural frequency and transmissibility at lowest operating speed of equipment.
  - 4. Where required, include independent test agencies certified report of test results for each type of unit.
  - 5. For spring units, show wire size, spring diameter, free height, solid-compression height, operating height, fatigue characteristics and ratio of horizontal to vertical stiffness.
  - 6. For spring-and-pad-type units show basis of spring-rate selection for range of loading weights.
  - 7. Include performance certifications where required.

### PART 2 - PRODUCTS

#### 2.1 ISOLATION MATERIALS AND SUPPORT UNITS

- A. Double deflection neoprene mountings shall have a minimum static deflection of 0.35". All metal surfaces shall be neoprene covered to avoid corrosion and have friction pads both top and bottom so they need not be bolted to the floor. Bolt holes shall be provided where bolting is required. On equipment such as small vent sets and close coupled pumps, steel rails shall be used above the mountings to compensate for the overhang.
- B. Vibration hangers shall contain a steel spring and 0.3" deflection neoprene element in series. The neoprene element shall be molded with a rod isolation bushing that passes through the hanger box. Spring diameters and hole sizes shall be large enough to permit the hanger rod to swing through a 30 degree arc before contacting the hole and short-circuiting the spring. Springs shall have a minimum additional travel to solid equal to 50% of the rated deflection.
- C. Vibration hangers shall be as described above, but they shall be precompressed to the rated deflection so as to keep the piping or equipment at a fixed elevation during installation. The hangers shall be designed with a release mechanism to free the spring after the installation is complete and the hanger is subjected to its full load. Deflection shall be indicated by a scale.
- D. Vibration hangers shall contain a steel spring located in a neoprene cup manufactured with a grommet to prevent short-circuiting. The cup shall contain a steel washer designed to properly distribute the load on the neoprene and prevent its extrusion. Spring diameters and hole sizes shall be large enough to permit the hanger rod to spring through a 30 degree arc before contacting the hole and short circuiting the spring. Springs shall have as minimum additional travel to solid equal to 50% of the rated deflection. Hangers shall be provided with an eyebolt on the spring end and provision to attach the housing to the flat iron duct straps.

- E. Vibration isolator shall be steel members welded to height saving brackets to cradle machines having legs or bases that do not require a complete supplementary base. Members shall be sufficiently rigid to prevent strains in the equipment.
- F. Flexible neoprene connectors shall be used on all equipment as indicated on the drawings. They shall be manufactured of multiple plies of nylon tire cord fabric and neoprene. No steel wire or rings shall be used as pressure reinforcement. Straight connectors shall have two spheres. Neoprene elbows shall have a single sphere forming the corner of the joint itself. Connectors up to and including 2" diameter may have threaded ends. Connectors 2-1/2" and larger shall have floating steel flanges. All connectors shall be rated a minimum of 150 psi at 200 degrees F. All sizes operating at pressures above 100 psi shall employ control cables with end fittings isolated from the anchoring plates by means of 1/2" thick bridge bearing neoprene washer bushings designed for a maximum of 1000 psi.
- G. Flexible stainless steel hose shall have stainless steel braid and carbon steel fittings. Sizes 3" and larger shall be flanged. Smaller sizes shall have male nipples. Lengths shall be as tabulated:

<u>Flanges</u>		<u>Male Nipples</u>	
3 x 14	10 x 26	1/2 x 9	1-1/2 x 13
4 x 15	12 x 28	3/4 x 10	2 x 14
5 x 19	14 x 30	1 x 11	2-1/2 x 18
6 x 20	16 x 32	1-1/4 x 12	
8 x 22			

- H. Hoses shall be installed on the equipment side of the shut-off valves horizontally and parallel to the equipment shafts wherever possible. Hoses shall be type BSS.
- I. Where piping passes through equipment walls, floors or ceilings, the vibration isolator shall be a split seal consisting of two bolted pipe halves with 3/4" or thicker neoprene sponge bonded to the inner faces. The seal shall be tightened around the pipe to eliminate clearance between the inner sponge face and the piping. Concrete may be packed around the seal to make it integral with the floor, wall or ceiling if the seal is not already in place around the pipe prior to the construction of the building member. Seals shall project a minimum of 1" past either face of the wall. Where temperatures exceed 240 degrees F., 10# density fiberglass may be used in lieu of the sponge.
- J. Isolator pads shall be neoprene waffle rated for 60#/sq. in.
- K. Pipe Riser Isolators: Provide manufacturer's standard pad-type isolator bonded to steel plate, formed for welding to pipe sleeve extension.

**PART 3 - EXECUTION**

**3.1 PERFORMANCE OF ISOLATORS**

- A. General: Comply with the minimum static deflections recommended by ASHRAE, including the definitions of critical and non-critical locations, for the selection and application of vibration isolation materials and units as indicated.

- B. Manufacturer's Recommendations: Except as otherwise indicated, comply with manufacturer's recommendations for selection and application of vibration isolation materials and units.

### 3.2 APPLICATIONS

- A. General: Apply the types of vibration isolation materials and units indicated at the locations shown or scheduled. Selection is Contractor's option where more than one type is indicated.
- B. Provide Neoprene Pads at the following locations/items of equipment:
  - 1. Where shown on drawings.
- C. Provide Vibration Isolation Springs for the following items of equipment:
  - 1. Where shown on drawings.
- D. Provide Spring Isolator, housed at the following items of equipment:
  - 1. Where shown on drawings.
- E. Provide Isolation Hangers for the following:
  - 1. Piping connected to machinery.

### 3.3 INSTALLATION

- A. General:
  - 1. Except as otherwise indicated, comply with manufacturer's instructions for the installation and load application to vibration isolation materials and units.
  - 2. Adjust to ensure that units do not exceed rated operating deflections or bottom out under loading, and are not short-circuited by other contacts or bearing points.
  - 3. Remove spacer blocks and similar devices (if any) intended for temporary protection during shipping or against overloading during installation.
  - 4. Anchor and attach units to substrate and equipment as required for secure operation and to prevent displacement by normal forces, and as indicated.
  - 5. Adjust leveling devices as required to distribute loading uniformly onto isolators. Shim units as required where leveling devices cannot be used to distribute loading properly.
  - 6. Install inertia base frames on isolator units as indicated, so that a minimum of 2" clearance below base will result when frame is filled with concrete and supported equipment has been installed and loaded for operation.
  - 7. Locate isolation hangers as near the overhead support structure as possible.
  - 8. Weld riser isolator units in place as required preventing displacement from loading and operations.

### 3.4 EXAMINATION OF RELATED WORK

- A. Installer of vibration isolation work shall observe the installation of other work related to vibration isolation work, including work connected to vibration isolation work; and, after completion of other related work (but before equipment startup), shall furnish a written report to the Contractor listing observed inadequacies for proper operation and performance of vibration isolation work. Report shall cover, but not necessarily be limited to the following:



1. Equipment installations (performed as work of other sections) on vibration isolators.
  2. Piping connections including flexible connections.
  3. Passage of piping which is to be isolated through walls and floors.
- B. Do not start-up equipment until inadequacies have been corrected in a manner acceptable to the vibration isolation Installer.

3.5 DEFLECTION MEASUREMENTS

- A. Upon completion of vibration isolation work, take measurements and prepare a report showing measured equipment deflections for each item of equipment.

**END OF SECTION**

THIS PAGE INTENTIONALLY LEFT BLANK

## SECTION 23 05 53 - IDENTIFICATION FOR HVAC PIPING AND EQUIPMENT

### PART 1 - GENERAL

#### 1.1 RELATED DOCUMENTS

- A. The Drawings and General Provisions of the Contract, including General and Supplementary Conditions and Division 01 Specification Sections, apply to the Work in this Section.

#### 1.2 SCOPE

- A. Provide all equipment, materials, labor, supervision, and services necessary for or incidental to the installation of all necessary identification items as indicated on the drawings and as specified.
- B. Work included:
  - 1. Valve tagging
  - 2. Pipe marking
  - 3. Equipment marking
- C. Submittals: **Provide submittals as required in Section 23 00 10. "Submittal Process".**

#### 1.3 QUALITY ASSURANCE

- A. Use adequate numbers of skilled workmen who are thoroughly trained and experienced in the necessary crafts and who are completely familiar with the specified requirements and the methods needed for proper performance of the work of this Section.
- B. Without additional cost to the Owner, provide such other labor and materials as are required to complete the work of this Section in accordance with the requirements of governmental agencies having jurisdiction, regardless of whether such materials and associated labor are called for elsewhere in these Contract Documents.
- C. When requested, provide the Architect with manufacturer's certificate that materials meet or exceed minimum requirements as specified. Marking system shall conform to ASME 13.1, latest edition and OSHA 29 CFR 1910.261 requirements.

### PART 2 - PRODUCTS

#### 2.1 VALVE TAGS

- A. Provide a tag for each valve in main and branch piping of natural gas and refrigerant piping systems.
  - 1. Tags shall be 1-1/2" diameter of solid brass with blacked filled stamped characters of 1/4" height above and 1/2" height below.
  - 2. Provide 8" long meter seals for use with valve tags.
- B. Provide a valve chart with a schedule and location plans for all identified equipment, both in a frame with an acrylic cover to be located as directed by the Architect.

**2.2 PIPE MARKERS**

- A. Provide pipe markers for pipes that provide 360 degree visibility with ANSI approved color coded background, color of legend in relation to background color, legend letter size, and length of color field. Additionally, direction of flow arrows shall be printed on the same markers, and words shall be repeated and reversed for use with flow in either direction.
  - 1. Each marker shall be formed with a clear acrylic covering suitable for use outdoors.
  - 2. For diameters 3/4" to 6", marker shall be formed in order to snap on and completely surround the pipe. For diameters 6" and larger, provide radius formed markers of same material.

**2.3 EQUIPMENT PLATES**

- A. Plate shall be black with white letters that appear when the plate is engraved.
- B. Plate material shall be specifically suited for conditions surrounding the equipment. Outdoor equipment shall require special plate material for outdoor use.
- C. Plate size shall be as required with lettering size appropriate for the information shown but in no case less than 1/8" high. Lettering style shall match existing facility standards.
- D. Nomenclature for plates shall be based on the equipment designations shown on the equipment schedules and as approved by the Architect.

**2.4 CONCEALED DEVICES**

- A. Operable devices and equipment located above ceilings shall be marked with color coded W. H. Brady "Tack" type markers.

**2.5 MANUFACTURERS**

- A. Provide marking system as manufactured by W. H. Brady Company, Seton, Craftmark, or approved equal.

**PART 3 - EXECUTION**

**3.1 GENERAL**

- A. Place all markers and plates in such locations that they are easily read by a person without assuming awkward or hazardous positions.

**3.2 VALVE TAGS**

- A. Secure one valve tag to each valve.

**3.3 PIPE MARKERS**

- A. For diameters 3/4" to 6", markers shall snap around the pipe, completely surrounding the pipe. Markers shall not require taping or the use of any adhesive material or fasteners to permanently secure them to the pipe. For diameters 6" and larger, secure with stainless steel spring fasteners.
- B. Install sufficient quantities of markers that tracing of pipe systems can be readily accomplished. Install within three feet before and/or after penetrations through walls, floors, ceilings, underground or other non-accessible enclosures; at access doors, manholes or other access points which permit view of concealed piping; and when there is a change in direction of the concealed pipe. Locations in major mechanical rooms shall be labeled at a maximum spacing of every 20 feet. Other piping shall have labels at a maximum spacing of every 30 feet and at least once in every area that the pipe passes over or through. Install additional markers where directed by the Architect.

**3.4 EQUIPMENT PLATES**

- A. Provide engraved plates for all HVAC equipment and all remote mounted starter/disconnects.
- B. Secure all plates with two self-tapping metal screws with round heads. Alternately, plates may be fastened with "pop" rivets provided no cracking or injury occurs to the plate. Plates attached with adhesives shall not be permitted.

**END OF SECTION**

THIS PAGE INTENTIONALLY LEFT BLANK

**SECTION 23 05 93 - TESTING, ADJUSTING, AND BALANCING FOR HVAC**

PART 1 - GENERAL

1.1 RELATED DOCUMENTS

- A. The Drawings and General Provisions of the Contract, including General and Supplementary Conditions and Division 01 Specification Sections, apply to the Work in this Section.

1.2 SUMMARY

- A. Testing and Balancing Agency Qualifications
1. The testing, adjusting, and balancing of the heating, ventilating and air conditioning systems shall be performed by a technical firm or balancing agency certified in Air and Hydronic TAB and system commissioning by the Associated Air Balance Council (AABC) or National Environmental Balancing Bureau (NEBB). The TAB agency shall also employ a permanent full time Registered Professional Engineer on staff with a minimum of five years specialized experience in testing and balancing. The testing and balancing agency shall possess calibrated instruments, qualified engineers, and skilled technicians to perform required tests in accordance with the AABC or NEBB National Standards.
  2. The testing and balancing agency shall be an independent firm separate and distinct from; not to be associated with, or be subsidiary of a firm performing work under other Sections of Division 22 & 23 and shall be under contract directly to the Owner.
- B. Testing and Balancing Agency Responsibilities
1. Submittals
    - a. Engineer and Technicians Data: Submit proof that the agency, the Test and Balance Engineer assigned to supervise the procedures, and the technicians proposed to perform the procedures meet the qualifications specified.
    - b. Sample Form: Submit sample forms, proposed for use on this project, for approval.
    - c. Certified Reports: Submit testing, adjusting, and balancing reports bearing the seal and signature of the Certified Agency.
    - d. **Certification from VRF manufacturer for test and balance of VRF products. Without this certification, the T&B company will not be considered an approved T&B company for VRF products**
  2. Review the construction documents, submittal, and shop drawings for balance ability. Submit a list of suggestions or recommendations to the Architect/Engineer for consideration.
  3. Perform a job site observation prior to the ceiling installation to verify that ductwork, piping, dampers, valves, and air terminal devices have been installed per the contract documents. Submit in writing to the Architect/Engineer a list of any discrepancies noted.
  4. Test, adjust and balance the heating, ventilating, and air conditioning systems in accordance with AABC or NEBB National Standards for field measurement.
  5. Verify the operation, calibration, and set points of all heating, ventilating, and air conditioning systems controls.

6. Functional performance tests of the control and smoke purge system and its components.
  7. Submit in writing to the Architect/Engineer a list of deficiencies for correction by the installing contractor. In the event a deficiency remains after being reported as corrected, the balancing agency may submit an itemized request for its lost time for payment by the installing contractor. All deficiencies that prevent proper T&B work from being completed shall be corrected prior to submittal of the Final T&B Report.
  8. Measure and record space temperature readings after occupancy for a period of two consecutive eight hour periods. Make adjustments if necessary to achieve an even temperature distribution.
  9. Submit certified, bound, typewritten report for approval by the Owner and Architect/Engineer including all test report data, instrument calibration, and schematic drawings of the HVAC layout.
  10. Provide preliminary smoke testing and smoke testing for all authorities having jurisdiction. Preliminary smoke testing must be completed in the presence of the architect/engineer and must be completed a minimum of 14 days prior to any smoke tests scheduled for authorities having jurisdiction. **Provide all materials required to perform smoke tests.**
  11. Make a total of three inspections within 90 days after occupancy of the building to insure that satisfactory conditions are being maintained. Submit a report of the findings to the Owner and Architect/Engineer.
  12. Make an inspection in the building during the opposite season from which the initial adjustments were made. At that time, make any necessary modifications to the initial adjustments required to produce optimum operation of the system for all seasons. Submit a report of the findings to the Owner and Engineer.
- C. Contractor Responsibilities
1. The Contractor shall provide the T&B firm with copies of all Drawings, Specifications, Shop Drawings, Submittal Data, Up-to-Date Revisions, Change Orders, and other data required for planning, preparation and execution of the T&B work.
  2. Coordinate the HVAC installation and start up schedule with the T&B Agency and General Contractor to allow sufficient time prior to the completion date for testing and balancing to be conducted and deficiency items corrected and retested. Provide sufficient personnel and utilities to operate the HVAC systems during normal and overtime hours to meet the completion date and testing and balancing schedule.
  3. The Mechanical Contractor shall install all systems complete and provide balancing valves, test plugs, thermometer wells, flow measurement orifices, volume dampers, splitter dampers, etc. necessary for T&B work. All equipment shall be operated at the Contractor's expense for a minimum of three consecutive days prior to balancing in order to make certain the equipment is free from mechanical defects, runs smoothly and quietly, and performs satisfactorily to meet the requirements set forth in the contract documents.
  4. Provide written notification to the T&B agency and General Contractor the systems are ready for balancing. Should the systems not be ready for balancing, it shall be the Contractor's responsibility to compensate the T&B Agency for time lost.
  5. Correct any deficiency items noted during testing and balancing including controls calibration, installation of balancing devices, sheave replacements, and motor replacements at no additional cost to the Owner. Provide written notification to the Testing and Balancing Agency and General Contractor when



systems are ready for retesting. Should the systems not be ready for retesting it shall be the Contractors responsibility to compensate the T&B Agency for time lost.

6. It shall be the responsibility of the Contractor to install all valves, dampers, and other adjustment devices in a manner that will leave them accessible and readily adjustable.
7. The Control Contractor shall provide and install the control system, complete with all temperature, pressure and humidity sensors installed and calibrated for accurate control.
8. Perform all tests of plumbing and piping systems and equipment as specified herein and as required to obtain approvals from all authorities having jurisdiction.
9. Provide all instruments, materials and labor to perform the testing and to obtain and record all measurements.
10. The Contractor is to perform duct leakage testing in accordance with the latest edition of the SMACNA - HVAC Air Duct Leakage Test Manual and maintain a log book on site indicating the area tested, date tested, leakage amount, and personnel performing the test. At the end of the project submit a final type written report with the results. The test and balance agency is to be notified one week prior to duct leakage testing and at their option witness the testing to confirm the testing is being performed in accordance with these specifications.

## PART 2 - PRODUCTS

### 2.1 EQUIPMENT

- A. The balancing agency shall have a complete set of instruments as required by AABC or NEBB standards.
- B. Calibration histories for each instrument used for measurement shall be available for examination. Calibration, accuracy, and maintenance of all instruments shall be in accordance with AABC standards.

## PART 3 – EXECUTION

### 3.1 CLEANING AND ADJUSTING

- A. Equipment, piping, valves, fittings and fixtures shall be cleaned of grease, metal cuttings and foreign matter that may have accumulated from operation of the system during the test. Any stoppage, discoloration or other damage to the finish, furnishings or parts of the building, due to the Contractor's failure to properly protect such items shall be repaired by the Contractor without additional cost to the Owner.
- B. When the work is complete, the water systems shall be adjusted for all required flows. Flush valves and automatic control devices shall be adjusted for proper operation. Hot water heaters shall be tested for proper operation of all safety and operating controls as recommended by the manufacturer. Demonstrate that supply and recirculation systems are balanced for specified flows and temperatures and as shown on the drawings.
- C. Sterilization: After pressure tests have been made, the entire domestic water distribution system shall be thoroughly flushed with water until all entrained dirt and mud have been removed, and shall be sterilized by chlorinating material. The chlorinating material shall be either liquid chlorine conforming to Federal Specification BB-C-120 or hypochlorite

conforming to Federal Specification 0-C-114, Type II, Grade B, or Federal Specification 0-S-602, Grade A or B. The chlorinating material shall provide a dosage of not less than 50 parts per million and shall be introduced into the system in an approved manner. The treatment water shall be retained in the pipe long enough to destroy all non-spore forming bacteria. Except where a shorter period is approved, the retention time shall be at least 24 hours and shall produce not less than 10 ppm of residual chlorine at the extreme end of the system at the end of the retention period.

- D. All valves and faucets in the system being sterilized shall be opened and closed several times during the contact period. The system shall then be flushed with clean water until the residual chlorine is reduced to less than 1.0 ppm. Samples of water shall be taken from several points in the system in properly sterilized containers for bacterial examination. The sterilizing shall be repeated until tests indicate the absence of pollution for at least two full days. The system will not be accepted until satisfactory bacteriological results have been obtained.

**3.2 EQUIPMENT AND SYSTEM TESTS**

- A. General: The Test and Balance firm shall test all HVAC equipment and systems and make final adjustments and corrections necessary to place the systems in proper operating condition.
  - 1. After testing and balancing, patch insulation, ductwork, and housings, using materials identical to those removed. Air test drilled openings shall be sealed with plastic plugs to allow future access. Seal insulation to re-establish integrity of the vapor barrier.
  - 2. Mark equipment settings, including damper control positions, valve indicators, fan speed control levers, and similar controls and devices to show final settings.
- B. Air Distribution Devices:
  - 1. Proportion each air handling unit, damper, register, diffuser and grille so that air distribution will be as scheduled, with tests showing air quantities indicated for each inlet and outlet that do not vary by more than plus or minus 10 percent from those indicated on the drawings.
- C. Ductwork:
  - 1. The contractor shall perform duct leakage testing on 25% of the supply, return and exhaust ductwork in accordance with SMACNA - HVAC Air Duct Leakage Test Manual. Seal any ductwork not meeting the following acceptable leakage rates and retest until test is successful.

<u>Duct System</u>	<u>Allowable % Leakage</u>
Low Pressure Supply	2% @ construction pressure class
Low Pres. Return/Exhaust	2% @ construction pressure class
Smoke Exhaust	2% @ construction pressure class

- D. Gas System:
  - 1. The complete gas piping system shall be tested with air at a pressure of fifteen (15) PSI and proved tight at such pressure for twenty-four (24) hours. Test may be done in segments as dictated by construction requirements. Peppermint fumes or soap bubbles shall be used to locate leaks. All tests shall be approved by the local authorities and reviewed by a representative of the Architect before the tests are removed.

- E. Fan Balancing:
1. Provide proper fan design and balance fans and drives to limit vibration (displacement in mils) at operating speed to the values in the following table unless specified elsewhere. Measure vibration at each fan bearing, in all three planes.

**FAN VIBRATION CRITERIA**

Fan RPM (peak-to peak)	Mils (in each plane)
500	4.2
800	3.0
1200	2.0
1700	1.5
2000 and greater	1.3

**3.3 SYSTEM OPERATING TESTS**

- A. After the successful completion of all equipment start-up and test requirements, the following formal testing and balancing shall be performed on the complete mechanical system:
1. Temperature Controls - The balancing agency shall be assisted by the temperature controls contractor in the commissioning of the operation and calibration of all temperature control systems. The following tests are required:
    - a. Verify all controlling devices are calibrated and set for design operating conditions.
    - b. Verify all components are installed and functional.
    - c. Verify the accuracy of each temperature sensor by temperature measurement.
    - d. Check the sequence of operation for all control modes to ensure that they are in accordance with the contract documents.
    - e. Verify that default setpoints are correct if different from the normal operating set points.
    - f. Verify all interlock systems function.
    - g. Perform all system verifications to assure the safety of the system and its components.
    - h. Verify changeover from heating to cooling occurs as specified.
    - i. Calibrate and adjust all thermostats and other controlling devices.
    - j. Replace defective controllers at no cost to the Owner.
  2. Mechanical Contractor Responsibility
    - a. Final Operating Test: An operating test shall be performed by the Contractor to the satisfaction of the Architect and the Owner for a period of not less than 8 hours. Should any element of the system not perform properly, the Contractor shall make all required corrections, and the test shall be repeated until successfully performed

**3.4 AIR SYSTEM PROCEDURES**

- A. The balancing agency shall perform the following testing and balancing functions in accordance with the AABC or NEBB National Standards for TAB.
1. Diffusers and Grilles - Determine air velocity at outlets with a velometer or anemometer and using air device manufacturer's data, calculate the delivery cfm, or determine cubic feet per minute flow with a test hood.
  2. Fans - Test supply, return, exhaust fans and adjust fan blower speeds to achieve specified CFM.

3. Current and Voltage - Measure and record motor full load amperage and voltage. Actual amperages higher than nameplate full load amps are not acceptable. Verify heater sizes.
4. Pitot-tube Traverse - Perform a Pitot-tube traverse (minimum of 16 points) on main supply and return ducts to obtain design CFM. If a Pitot-tube traverse is not practical, the summation of the outlets or inlets may be used with an explanation why a traverse was not conducted.
5. Outside Air - Test and adjust system minimum outside air by Pitot-tube traverse. If a Pitot-tube traverse is not practical, the percentage of outside air may be determined by calculations from the return air, outside air, and mixed air temperatures when the temperature differential between the return and outside air is greater than 20°F.
6. Static Pressure - Test and record system static pressures, including entering and leaving static pressures of each fan, coil section, and filter section. For VAV systems, establish and record the minimum operating static pressure setpoint required for the air handling unit to achieve design airflow at the last terminal box in the system.
7. Air Temperature - Take wet bulb and dry bulb air temperatures on the entering and leaving side of each cooling coil. Dry bulb temperature shall be taken on the entering and leaving side of each heating coil.
8. Main Ducts - Adjust main ducts to within design CFM requirements and traverse for total CFM quantities.
9. Branch Ducts - Adjust branch ducts to within design CFM requirements. Multi-diffuser branch ducts shall have at least one volume damper completely open.
10. Tolerances
  - a. Test and balance each diffuser, grille and register to within 10% of design requirements.
  - b. Test and balance each fan and air-handling unit to within plus 10% and minus 5% of design requirements. Test and balance units having filters with clean filters in place.
11. Minimizing Drafts - Adjust all diffusers, grilles, and registers to minimize drafts in all areas.
12. If inspections or tests reveal defects, such defective work or material shall be replaced or repaired as necessary and inspections and tests shall be repeated. Repairs to piping shall be made with new materials. Patching of screwed joints or holes shall not be acceptable.

### 3.5 TEST AND BALANCE REPORT

- A.. The Final TAB Report shall be typewritten on 8.5 x 11 inch white bond paper, in bound form with an index and tabs to segregate the data into logical sections. The summary shall include information on special testing conditions and results. A listing of the TAB Agency, Contractor, Owner, Architect, and Engineer shall be included.
- B. The report shall present data entered on AABC or NEBB standard forms (modified as necessary to include additional data hereinafter required) or pre-approved acceptable equivalent thereof.
- C. The report shall contain copies of pump curves, fan curves, field test reports and as-built plans (size 11 x 17 inches) of the HVAC systems.
- D. Include a certification sheet containing the seal and name, corporate address, telephone number, and signature of the Certified Test and Balance Engineer.

- E. Include a listing of the instrumentation's used for the procedures along with the proof of calibration.
- F. System Identification - Each supply, return, and exhaust opening shall be identified and numbered on reduced plans no larger than 11 x 17 inches to correspond to the numbers used on the report data sheets.
- G. Air Outlet Test Report Forms - Each grille, diffuser, and register shall be identified as to location (room number) and area served. Record the size, type, and manufacturer of each diffuser, grille, and register.
- H. Air Handling Unit Test Report Forms - Record the manufacturer, model number and motor nameplate data and all design and manufacturer-rated data including supply, return, and outside airflows, fan rpm, sp, and bhp. Report the following.
  - 1. Total actual CFM by traverse. Include duct traverse form. If not practical, the sum of the outlets may be used, or a combination of each of these procedures.
  - 2. Inlet and outlet static pressures at the fan, coil and filter sections.
  - 3. Actual outside air and return air total CFM.
  - 4. Actual operating current, voltage, and brake horsepower of each fan motor.
  - 5. Final RPM of the fan and motor.
  - 6. Fan and motor sheave sizes and center distance. Belt size and quantity.
  - 7. For VAV air handling systems, report the minimum static pressure set point required to achieve design CFM to the last terminal box in the system while maintaining design airflow at the air handler.
  - 8. Coil EAT and LAT (db/wb), EWT, LWT, and air pressure drops.
  - 9. Outside air temperature (DB/WB).
- I. Fan Test Report Forms - Record the manufacturer, model number, motor nameplate data and all design and manufacturer-rated data. Report the following.
  - 1. Total actual CFM by traverse. Include duct traverse form. If not practical, the sum of the outlets may be used, or a combination of each of these procedures.
  - 2. Suction and discharge static pressure of each fan.
  - 3. Actual operating current, voltage, and brake horsepower of each fan motor.
  - 4. Final RPM of the fan and motor.
  - 5. Fan and motor sheave sizes and center distance. Belt size and quantity.
- J. Pumps Test Forms - Submit pump curve showing design, operating, and no-flow points of operation. Also, record the following items on each pump test form:
  - 1. Manufacturer, size, and serial number.
  - 2. All design and manufacturer's rated data.
  - 3. Pump operating suction and discharge pressure and final total dynamic head and apparent GPM.
  - 4. No flow (pump discharge valve closed) suction and discharge pressure and corresponding total dynamic head.
  - 5. Rated and actual operating current, voltage, RPM, and brake horsepower of each pump motor.

### 3.6 FINAL JOB MEETING

- A. At job completion, all Division 21, 22, 23, 26, and 28 representatives shall meet at the job site and shall demonstrate the operation of all equipment and systems. The Architect and Owner shall be advised in writing 10 days prior to the time and date of this inspection.

3.7 SYSTEM PERFORMANCE VERIFICATION:

A. Testing and Balancing Agency

1. At the time of final inspection, the Test and Balance Agency may be required to recheck, in the presence of the Owner's representative, specific and random selections of data, air quantities, and air motion recorded in the Certified Report.
2. Points and areas for recheck shall be selected by the Owner's representative.
3. Measurement and test procedures shall be the same as approved for work forming basis of Certified Report.
4. If random tests elicit a measured flow deviation of 10% or more from that recorded in the Certified Report the report will be rejected, all systems shall be retested, new data recorded, new Certified Report submitted, and new inspection tests made, at no additional cost to Owner.

**END OF SECTION**

## SECTION 23 07 00 - HVAC INSULATION

### PART 1 - GENERAL

#### 1.1 RELATED DOCUMENTS

- A. The Drawings and General Provisions of the Contract, including General and Supplementary Conditions and Division 01 Specification Sections, apply to the Work in this Section.

#### 1.2 SUMMARY

- A. Provide all equipment, materials, labor, supervision, and services necessary for or incidental to the insulation of the mechanical systems as indicated on the drawings and as specified herein.
- B. Factory insulated equipment is excluded from this section of the specifications except that the insulating material characteristics shall equal or exceed those of specified materials for similar service.
- C. Work Included:
  - 1. Piping:
    - a. Cooling coil condensate drain lines.
    - b. All refrigerant lines.
  - 2. Ductwork:
    - a. Supply air:
      - 1) Insulate externally with thermal duct wrap.
    - b. Return air:
      - 1) Insulate externally with thermal duct wrap.
    - c. Make-up air duct:
      - 1) Insulated externally.
    - c. All round ductwork exposed to view shall be double wall factory internally insulated with 1" thick glass fiber duct and fittings.
- D. **Submittals: Provide submittals as required in Section 23 00 10, "Submittal Process".**

#### 1.3 QUALITY ASSURANCE

- A. Use adequate numbers of skilled workmen who are thoroughly trained and experienced in the necessary crafts and who are completely familiar with the specified requirements and the methods needed for proper performance of the work of this Section.
- B. Without additional cost to the Owner, provide such other labor and materials as are required to complete the work of this Section in accordance with the requirements of governmental agencies having jurisdiction, regardless of whether such materials and associated labor are called for elsewhere in these Contract Documents.
- C. When requested, provide the Architect with manufacturer's certificate that materials meet or exceed minimum requirements as specified.
- D. Acceptable Manufacturers:
  - 1. Fiberglass Insulation:

- a. Owens-Corning Fiberglas
- b. Manville
- c. Certain Teed
2. Urethane Insulation:
  - a. Armstrong (Armalok)
  - b. Thermacor
3. Mastics:
  - a. Benjamin Foster
  - b. Insul-Coustic
  - c. Chicago Mastic
  - d. Childers Products
4. High Temperature Bonding Cements: Ryder Thermocote
5. PVC Fittings: Zeston, Inc.

#### 1.4 GENERAL

- A. All materials shall be applied by workmen skilled in this trade. Mechanical fasteners shall be used whenever possible to assure permanent construction. Unsightly work shall be cause for rejection.
- B. Materials will be applied only after all surfaces have been tested and cleaned.
- C. All material, jacket, coverings, sealers, mastics and adhesives shall not exceed flame spread rating of 25 and smoke developed of 50 in accordance with ASTM Method E84, UL Standard 723 and NFPA Bulletins 255 and 90A.
- D. Insulation shall be vermin resistant.
- E. Non-compressible insulation material shall be installed at hangers of cold piping to eliminate through metal conductance.
- F. Sizing, paint, pipe shield or saddle, and internal duct insulation shall be provided under other sections of Division 23.
- G. Insulation of cold surfaces shall be vapor sealed.
- H. Minimum thickness of insulation shall be as listed or energy code as adopted by authority having jurisdiction. However, sufficient insulation shall be provided to eliminate condensation on the cold surfaces and to maintain a maximum exterior insulation surface of 125°F. (OSHA Standard) on the hot surfaces.

#### PART 2 - PRODUCTS

##### 2.1 PIPING SYSTEMS

- A. Pipe Insulation:
  1. Above ground-Johns Manville AP-T preformed one-piece fiberglass with reinforced craft paper and aluminum foil jacket. Include vapor barrier where required.
    - a. Use pre-formed PVC fitting covers with fiberglass inserts. Fiberglass shall be same density as pipe insulation.



- b. Where insulation is exposed to weather, use Manville Flame-Safe ML, or approved equal, Metal-Jacketed Fiberglass pipe insulation. Attachment shall be made by 1/2" 0.020 aluminum bands with approved closure system.
2. **1" Armstrong SOLID CORE** Armaflex or equal **for all refrigerant lines**. Split Armaflex is not approved in refrigeration applications. **Both the liquid and gas refrigerant lines must be insulated**
3. Condensate drain lines shall be insulated from AC unit to indirect waste termination points and first 10'-0" of horizontal drain line at floor drains receiving condensate. Material shall be closed cell type with 3/4" thick molded pipe covering with a density of 7 lbs. thermal conductivity at 0.28 at 75°F. Do not split the insulation. All joints shall be glued with manufacturer's adhesive.

## 2.2 DUCTWORK SYSTEMS

- A. External insulation for metal ductwork (flexible blanket): Johns Manville Microlite fiberglass duct wrap with FSK reinforced craft paper and aluminum foil facing, conforming to the requirements of NFPA 90A and 90B.
- B. High velocity ductwork with external insulation shall be insulated with blanket wrap fiberglass insulation, 1-1/2 inches thick, one (1) pound density or minimum thermal resistance of 6.0, complete with scrim kraft jacket. Facing overlapping joints shall be at least two (2) inches and held in place with outward clinching staples on approximately four (4) inch centers. Underside of ducts exceeding 24 inches in diameter shall be spot cemented and finally secured with sheet metal screws and washers.
- C. High velocity flexible ductwork shall be UL 181, Class I, with rating to meet or exceed NFPA 90A-90B and reinforced with a perforated sheet metal inner jacket.
- D. High velocity ductwork located in non-conditioned spaces shall be insulated with 2" thick fiberglass board insulation with vapor barrier jacket.
- E. Other manufacturers are Certainteed, Knauf, and Owens Corning or approved equal.
- F. Fibrous-Glass Duct Liner: Comply with ASTM C 1071, NFPA 90A, or NFPA 90B; and with NAIMA AH124, "Fibrous Glass Duct Liner Standard."
  1. Acceptable Manufacturers: Subject to compliance with requirements, provide products by one of the following:
    - a. CertainTeed Corporation; Insulation Group.
    - b. Johns Manville.
    - c. Knauf Insulation.
    - d. Owens Corning.
  2. Maximum Thermal Conductivity: 0.27 Btu x in./h x sq. ft. x deg F at 75 deg F mean temperature.
  3. All duct liner products shall avoid air erosion up to velocities of 4,000 feet per minute.
- G. Solvent-Based Liner Adhesive: Comply with NFPA 90A or NFPA 90B and with ASTM C 916.

## 2.3 ADHESIVES

- A. Water based, polymeric, UL classified lagging adhesive for applying canvas and glass cloth; Foster 30-36 or Childers CP-50.
- B. A fast setting, rubber based, UL classified, vapor barrier lap and attachment adhesive; Foster 85-15 or Childers CP-85.
- C. Same adhesive, except non-flammable when wet; Foster 85-20 or Childers CP-82.
- D. A rubber based, UL classified, fast setting contact adhesive for adhering flexible cellular insulation; Foster 82-40 or Armstrong 520.

**2.4 INSULATION THICKNESS**

- A. Piping insulation thickness based on a maximum k value of 0.23 Btu in/hr ft<sup>2</sup> °F at a mean temperature of 75°F.

<b>Pipe Sizes</b>			
<b>System</b>	<b>Runouts To 12 ft. Max.</b>	<b>1 1/2" and Less</b>	<b>1 1/2" Up</b>
Refrigerant piping	1"	1"	2"
Condensate drain piping	1"	1"	1"

- B. Exterior Duct Insulation: All supply, return and outside air ductwork, shall be insulation 2" thick, with a minimum installed R value of 6.0.

**2.5 DUCT SEALANTS**

- A. A fast setting, rubber based, UL classified, high velocity duct sealer; Foster 32-14 or 3M EC-800.
- B. Same sealer, except non-flammable when wet; Foster 30-02.

**2.6 EXPANSION AND BALL JOINT INSULATION COVERS**

- A. Furnish and install removable and reusable insulation covers.
- B. Insulation and jacketing material shall be as required for service temperatures.
- C. Covers shall have hook and loop fasteners and draw cords

**PART 3 - EXECUTION**

**3.1 GENERAL**

- A. The installation of all insulation shall be made by experienced craftsmen in a neat,

workmanlike manner and shall be in accordance with the manufacturer's published recommendations for service intended, as interpreted by the Architect.

- B. All adhesives used in conjunction with insulation shall be compatible with the insulation and vapor barrier used and be vermin-proof and mildew resistant.

### 3.2 APPLICATION

- A. Install materials in accordance with manufacturer's instructions.
- B. Ductwork:
  - 1. External Duct Insulation: All external duct shall be installed without sagging or loose fitting sections. Outer jacket shall be sealed with mastic to form a continuous vapor barrier. Install as recommended by the insulation manufacturer.
  - 2. Flexible fiberglass insulation shall be wrapped around ducts and secured with outward clinching staples. Ducts 24" wide and larger shall have the insulation additionally secured with stick clips on 18" centers or with 4" wide bands of adhesive applied on 18" centers. Insulation shall be lapped a minimum of 4" and all seams and penetrations shall be sealed with an approved mastic reinforced with 3" glass mesh reinforcement. Where insulation terminates, all raw glass shall be sealed to duct.
- C. Insulation shall be the full specified thickness, continuous through walls, floors, ceilings, etc. Reducing thickness or cutting back of insulation to pass obstructions or through sleeves will not be permitted.
- D. Valve and fitting insulation shall be built up to the thickness of the adjacent pipe insulation or may be factory prefabricated units at the Contractor's option.
- E. Any painting of pipe insulation shall be accomplished under the Painting Section. After finish painting, any insulation showing splits or other signs of poor workmanship shall be replaced.
- F. No part of any system shall be insulated until all required tests have been completed.
- G. All insulation shall be installed so that it does not interfere with the functions of thermometer wells, gage connections and/or cocks, unions, access panels, hand holes, manholes, sight glasses, etc., or obscure serial numbers or other nameplate data.
- H. Insulation shall be extended to include stiff leg supports as required to prevent sweating.
- I. Complete vapor barriers to prevent sweating shall be installed on all cold systems and equipment. If a single tape adhesive system or staples are used for closure of the longitudinal lap, a vapor barrier mastic must be used to ensure a vaporproof closure. All edges and abutments shall be sealed, waterproof and vaporproof. Supplier of jacket materials shall certify that the material proposed is approved for use in return air plenums, where applicable.
- J. Where necessary, the application of insulation shall be arranged to accommodate movement of piping due to thermal expansion and/or contraction.
- K. **Exterior Refrigeration Piping: All pipe and fittings specified herein to be insulated when installed exposed to weather, and wrapped with an 0.016" smooth or**

**corrugated aluminum jacket with proper closure system positioned to shed water to make a waterproof assembly.** Fittings shall be insulated with molded insulation fittings or pipe insulation carved and mitered to fit properly. Insulation shall be butted together and adhered in place with contact cement. Where possible tubing shall be slipped on without slitting. Where insulation terminates, it shall be neatly beveled and finished. No portion of this insulation shall be concealed prior to approval by the Architect.

- L. Below Grade Piping: All pipe and fittings specified herein to be insulated, when installed below grade shall be insulated and spirally wrapped with open mesh glass tape embedded in asphaltic mastic and then completely covered with waterproof asphaltic mastic so as to make a waterproof assembly. Fittings shall be insulated with molded insulation fittings or pipe insulation carved and mitered to fit properly. Insulation shall be butted together and adhered in place with contact cement. Where possible tubing shall be slipped on without slitting. Where insulation terminates, it shall be neatly beveled and finished. No portion of this insulation shall be concealed before the Architect has checked and approved same.
- M. Piping supports shall pass completely around the exterior of the finished insulation. Rigid blocks of insulation material shall be provided at all support points. In addition, sheet metal saddles shall be provided at support points in accordance with the following table:

Pipe Size	Gauge Metal	Saddle Length
Up to 2-1/2"	18	6"
3" - 5"	16	10"
6" - 8"	16	14"
10" and Over	16	18"

- N. Saddles shall cover the bottom of the insulation, and saddle edges shall be hemmed or suitably covered to prevent damage to the insulation material.
- O. The vapor barrier and finish shall be continuous at all support points.
- P. Shop Application of Duct Liner: Comply with SMACNA's "HVAC Duct Construction Standards - Metal and Flexible," Figure 2-19, "Flexible Duct Liner Installation."
  1. Adhere a single layer of indicated thickness of duct liner with at least 90 percent adhesive coverage at liner contact surface area. Attaining indicated thickness with multiple layers of duct liner is prohibited.
  2. Apply adhesive to transverse edges of liner facing upstream that do not receive metal nosing.
  3. Butt transverse joints without gaps, and coat joint with adhesive.
  4. Fold and compress liner in corners of rectangular ducts or cut and fit to ensure butted-edge overlapping.
  5. Do not apply liner in rectangular ducts with longitudinal joints, except at corners of ducts, unless duct size and dimensions of standard liner make longitudinal joints necessary.
  6. Apply adhesive coating on longitudinal seams in ducts.
  7. Secure liner with mechanical fasteners 4 inches from corners and at intervals not exceeding 12 inches transversely; at 3 inches from transverse joints and at intervals not exceeding 18 inches longitudinally.

8. Secure transversely oriented liner edges facing the airstream with metal nosings that have either channel or "Z" profiles or are integrally formed from duct wall. Fabricate edge facings at the following locations:
  - a. Fan discharges.
  - b. Intervals of lined duct preceding unlined duct.
  - c. Upstream edges of transverse joints in ducts where air velocities are higher than 2000 fpm or where indicated.
9. Secure insulation between perforated sheet metal inner duct of same thickness as specified for outer shell. Use mechanical fasteners that maintain inner duct at uniform distance from outer shell without compressing insulation.
  - a. Sheet Metal Inner Duct Perforations: 3/32-inch diameter, with an overall open area of 23 percent.
- Q. Lined exterior ductwork shall be treated with an acid etch bath and two coats of UV resistant paint. Color shall be approved by Architect.
- R. Terminate inner ducts with buildouts attached to fire-damper sleeves, dampers, turning vane assemblies, or other devices. Fabricated buildouts (metal hat sections) or other buildout means are optional; when used, secure buildouts to duct walls with bolts, screws, rivets, or welds.

**END OF SECTION**

THIS PAGE INTENTIONALLY LEFT BLANK

**SECTION 23 09 00 - INSTRUMENTATION AND CONTROL FOR HVAC**

**PART 1 - GENERAL**

**1.1 RELATED DOCUMENTS**

- A. The Drawings and General Provisions of the Contract, including General and Supplementary Conditions and Division 01 Specification Sections, apply to the Work in this Section.

**1.2 SUMMARY**

- A. This Section includes control equipment for HVAC systems, components and other systems shown to be controlled by the existing Barber-Colman (Lon Works) Building Automation System (BAS), including, but not limited to, revised computer software, controllers, transmission equipment, local panels, installation, engineering, supervision, commissioning, acceptance testing, training and warranty service necessary for a complete and working system, revising all of the pneumatic to electronic actuators revising all of the pneumatic to electronic actuators.
- B. The Contractor shall furnish and install the controls including all necessary hardware and all revised operating and applications software necessary to perform the existing control sequences of operation as specified.
- C. All components of the system – local controllers, unitary controllers, etc. shall communicate using the BACnet protocol, as defined by the most current edition of ASHRAE Standard 135 and as specified herein or equal. Proprietary communications shall not be acceptable.
- D. The BAS contractor shall review and study all drawings and the entire specification to become familiar with the equipment and system operation and to verify the quantities and types of controllers and devices to be provided.
- E. All interlock, control and power wiring and installation of control devices associated with the equipment described in this specification, and maintain the existing sequence of operations, shall be provided under this Contract. All power wiring shall conform to the methods and materials described in Division 26 Section “Low-Voltage Electrical Power Conductors and Cables”.
- F. Provide services and manpower necessary for commissioning of the revised control system.
- G. All work performed under this section of the specifications will comply with all codes, laws and governing bodies. If the drawings and/or specifications are in conflict with governing codes, the Contractor shall submit a proposal with appropriate modifications to the project to meet code restrictions. If this specification and associated drawings exceed governing code requirements, the specification will govern. The Controls Contractor shall obtain and pay for all necessary construction permits and licenses associated with this scope of work.

**1.3 QUALITY ASSURANCE**

- A. Additions and revisions to existing Building Automation System (BAS) shall be manufactured, tested and installed in accordance with the following standards:
  - 1. National Electrical Manufacturers Association (NEMA).
  - 2. Underwriters Laboratories (UL).
  - 3. BACnet Testing Laboratories (BTL).

4. National Fire Protection Association (NFPA).
- B. Installer Qualifications: Automatic control system manufacturer's authorized representative who is trained and approved for installation of system components required for this Project.
- C. Upon completion of the installation, the Contractor shall thoroughly inspect, check, adjust, calibrate, and make ready for use all devices/sensors comprising the control system and certify that they are installed in accordance with "Record" Drawings.
- D. Electrical Components, Devices, and Accessories: Listed and labeled as defined in NFPA 70, Article 100, by a testing agency acceptable to authorities having jurisdiction, and marked for intended use.
- E. Data Communications Protocol: Certify that each proposed Controls system component complies with ASHRAE Standard 135 for each protocol.
- F. Controls system component testing: Comply with ASHRAE 135.1 and all addenda for all controllers.
- G. All controllers used to control or monitor equipment and/or field devices shall be tested, compliant with and carry the mark of the BACnet Testing Laboratories (BTL):
  1. Building Controllers.
  2. Advanced Application Controllers.
  3. Application Specific Controllers.
- H. Quality Management Program
  1. Designate a competent and experienced employee to provide BAS Project Management. The designated Project Manager shall be full time on this project and be empowered to make financial, technical, scheduling and related decisions on behalf of the BMS Contractor. At minimum, the Project Manager shall:
    - a. Serve as the point of contact for the Construction Team.
    - b. Manage the scheduling of the work to ensure that adequate materials, labor and other resources are available when needed.
    - c. Lead and be involved in the coordination efforts with other trades.
    - d. Be responsible for the work and actions of the BAS workforce on site.
- I. As evidence and assurance of the Contractor's ability to support the project's Commissioning efforts, the Contractor must have successfully completed three commissioned projects totaling at least the value of this contract, as a minimum.

#### 1.4 SUBMITTALS

- A. **Provide submittals as required in Section 23 00 10, "Submittal Process".**
- B. Product Data: For all products listed in Part 2 below provide detailed manufacturer product data, technical literature indicating dimensions, finishes, material, weights, performance characteristics, electrical characteristics, capacities, loads, required clearances, method of field assembly, components, and location and size of each field connection. Include manufacturer's technical literature for each control device. Indicate finishes for materials, and installation and startup instructions for each type of product indicated.
  1. Existing Control System Software: Include technical data for operating the revised system software and other third-party applications including all software licensing agreements.
  2. Revised Controlled Systems: Instrumentation list with element name, type of device, manufacturer, model number, and product data. Include schematic control diagram.



- C. Shop Drawings:
1. Bill of materials of equipment indicating quantity, manufacturer, and model number.
  2. Schematic flow/control diagrams showing fans, pumps, coils, dampers, valves, and control devices.
  3. Wiring Diagrams: Power, signal, and control wiring.
  4. Conductor numbering or color code schedules.
  5. Details of control panel faces, including controls, instruments, and labeling.
  6. Schedule of identification labels for controllers and devices.
  7. Floor plans indicating control panel locations.
  8. Schedule of dampers including size, leakage, and airflow characteristics.
  9. Revised Control System Hardware:
    - a. Wiring diagrams for control units with termination numbers.
    - b. Schematic diagrams and floor plans for control hardware.
    - c. Schematic diagrams for control, communication, and power wiring.
  10. Revised Control System Software (as required): Graphics outline and "Print Page" examples of final product indicating monitored systems, data (connected and calculated) point addresses, output schedule, and operator notations.
  11. Controlled Systems:
    - a. Schematic diagrams of each controlled system with control points labeled and control elements graphically shown, with wiring.
    - b. Scaled drawings showing mounting, routing, and wiring of elements including bases and special construction.
    - c. Points list.
  12. Submit hard and soft copies in file format compatible with AutoCAD 2012.
- D. Data Communications Protocol Certificates: Certify that each proposed control system component complies with ASHRAE Standard 135 for each protocol.
- E. Software Update and Firmware Operational Documentation: Include the following:
1. Revised Software operating and upgrade manuals.
  2. Program Software Backup required to reinstall and configure system in the event of a catastrophic failure: On CD, complete with data files.
- F. Field quality-control test report forms.
- G. Contract Closeout Documentation:
1. Revisions to Operation and Maintenance Data: Include emergency, operation, and maintenance manuals. In addition to items specified in Division 01 Section "Operation and Maintenance Data," include the following:
    - a. Maintenance instructions and lists of spare parts for each type of control device.
    - b. Interconnection wiring diagrams with identified and numbered system components and devices.
    - c. Inspection period, cleaning methods, cleaning materials recommended, and calibration tolerances.
    - d. Calibration records and list of set points.
- 1.5 WARRANTY
- A. Controls Contractor shall guarantee all system components and installations to be free from defects for one (1) year from the date of acceptance as determined by the Owner. Any defects found during this period shall be repaired and/or replaced at no cost to the Owner. The Controls Contractor shall provide maximum of 24-hour response time for trouble calls or maintenance.

- B. Controls Contractor shall provide all corrective software modifications or updates available from the software manufacturer during warranty service periods. All user documentation shall be updated on user and manufacturer backup software disks.

#### 1.6 WORK BY OTHERS

- A. The installation of motor starters that are not factory installed, thermal overload switches, and power wiring to motors, starters, and thermal overload switches, is specified in another section. This section includes the furnishing and installing of all controls, devices, interlocks, and wiring to provide a complete operating system as outlined in the existing building sequence of operation.
- B. The following general work scope of Contractors requiring coordination by the Controls Contractor includes, but is not limited to:
  - 1. Electrical Contractor shall:
    - a. Provide dedicated 120VAC circuits in j-boxes throughout all building areas for control panel and terminal box control power.

### PART 2 - PRODUCTS

#### 2.1 ACTUATORS

- A. Electric Motors: Size to operate with sufficient reserve power to provide smooth modulating action or two-position action.
  - 1. Nonspring-Return Motors for Dampers Larger Than 25 Sq. Ft.: Size for running torque of 150 in. x lbf and breakaway torque of 300 in. x lbf.
  - 2. Spring-Return Motors for Dampers Larger Than 25 Sq. Ft.: Size for running and breakaway torque of 150 in. x lbf.
- B. Electronic Actuators shall be of 0 10 VDC type. Direct-coupled type designed for minimum 60,000 full-stroke cycles at rated torque. The minimum actuator impedance shall be 800 ohms even when more than one actuator is connected in parallel. Spring return shall be required for two-position (NO/NC) control sequence or for steam valve control. Non-spring return actuators shall be used for all modulating sequence of control. They shall conform to all requirements of sequence descriptions specified or scheduled. Main mechanical equipment actuators shall have a manual position dial to allow manual positioning of valve in absence of control power.
  - 1. Dampers: Size for running torque calculated as follows:
    - a. Opposed-Blade Damper with Edge Seals: 5 inch-lb/sq. ft. of damper.
    - b. Opposed-Blade Damper without Edge Seals: 3 inch-lb/sq. ft. of damper.
    - c. Parallel-Blade Damper with Edge Seals: 7 inch-lb/sq. ft. of damper.
    - d. Parallel-Blade Damper without Edge Seals: 4 inch-lb/sq. ft. of damper.
    - e. Dampers with 2- to 3-Inch wg of Pressure Drop or Face Velocities of 1000 to 2500 fpm: Increase running torque by 1.5.
    - f. Dampers with 3- to 4-Inch wg of Pressure Drop or Face Velocities of 2500 to 3000 fpm: Increase running torque by 2.0.
    - g. Nonspring-Return Motors for Dampers Larger Than 25 Sq. Ft.: Size for running torque of 150 in. x lbf and breakaway torque of 300 in. x lbf.
    - h. Spring-Return Motors for Dampers Larger Than 25 Sq. Ft.: Size for running and breakaway torque of 150 in. x lbf.
  - 2. Coupling: V-bolt and V-shaped, toothed cradle.
  - 3. Overload Protection: Electronic overload or digital rotation-sensing circuitry.
  - 4. Fail-Safe Operation: Mechanical, spring-return mechanism. Provide external, manual gear release on nonspring-return actuators.
  - 5. Power Requirements (Two-Position Spring Return): 24-Vac.

6. Power Requirements (Modulating): Maximum 10 VA at 24-V ac or 8 W at 24-V dc.
  7. Proportional Signal: 2- to 10-V dc or 4 to 20 mA, and 2- to 10-V dc position feedback signal with damper position indicator indicating percent of travel.
  8. Temperature Rating: Minus 0 degrees to plus 122 deg F.
  9. Actuator Housing: Molded or die-cast zinc or aluminum.
  10. Comply with NEMA designation.
  11. Size to operate with sufficient reserve power to provide smooth modulating action or two-position action.
    - a. Permanent Split-Capacitor or Shaded-Pole Type: Gear trains completely oil immersed and sealed. Equip spring-return motors with integral spiral-spring mechanism in housings designed for easy removal for service or adjustment of limit switches, auxiliary switches, or feedback potentiometer.
- C. Actuators for smoke dampers shall be 24V floating point, 0-10Vdc, modulating and their position shall be readable as open or closed via end switch at the OWS.

## 2.2 CONTROL CABLE

- A. Electronic and fiber-optic cables for control wiring are specified in Division 27 Section "Communications Horizontal Cabling".

## PART 3 - EXECUTION

### 3.1 DELIVERY, STORAGE, AND HANDLING

- A. Factory-Mounted Components: Where control devices specified in this Section are indicated to be factory mounted on equipment in other Sections, arrange for shipping of control devices to equipment manufacturer. Upon delivery the equipment manufacturer shall inspect shipment for visual damages. The Controls Contractor shall replace any damaged control equipment at no cost to the Owner.
- B. Provide factory shipping containers for each piece of equipment. Provide factory applied plastic end caps on each length of pipe and tube. Maintain cartons and end caps through shipping, storage and handling as required to prevent equipment and pipe-end damage, and to eliminate dirt and moisture from equipment and inside of pipe and tube. Where possible store equipment and materials inside and protected from weather. When necessary, to store outside, elevate well above grade and enclose with durable water-proof wrapping.

### 3.2 EXAMINATION

- A. Verify that power supply is available to all controllers, and electric actuators.

### 3.3 COORDINATION

- A. Coordinate equipment with Division 28 Section "Fire Detection and Alarm" to achieve compatibility with equipment that interfaces with that system.
- B. Coordinate supply of conditioned electrical branch circuits for control units with Division 26 contractor. BAS contractor responsible for work associated with installation of power supply from electrical panelboard to all powered controllers and devices.
- C. Coordinate equipment with Division 26 Section "Electrical Power Monitoring and Control" to achieve compatibility of communication interfaces.

- D. Coordinate equipment with Division 26 Section "Panelboards" to achieve compatibility with starter coils and annunciation devices.

### 3.4 INSTALLATION

- A. Install software in control units. Implement all features of programs to specified requirements and as appropriate to achieve the existing sequence of operations.
- B. Connect and configure equipment and software to achieve the existing sequence of operations.
- C. Install damper motors on outside of duct in warm areas, not in locations exposed to outdoor temperatures.
- D. Install labels and nameplates to identify control components according to existing Base Building Division 23 standards.

### 3.5 ELECTRICAL WIRING AND CONNECTION INSTALLATION

- A. Install systems and materials in accordance with manufacturer's instructions, rough-in drawings and equipment details. Install electrical components and use electrical products complying with requirements of applicable Division 26 Sections of these Specifications except where specifically stated in this Section.
- B. The term "control wiring" is defined to include providing of wire, conduit, and miscellaneous material as required for mounting and connecting electric or electronic control devices.
- C. Install all control wiring in conduit for electric/electronic control systems. Conceal wiring, except in mechanical rooms and areas where other conduit and piping are exposed. UL plenum rated cable shall be allowed above accessible lift out ceilings, in air plenums and in other areas as approved by Engineer and local and NEC codes.
- D. Stub conduit to above lift out ceilings. Plastic bushing shall be installed where the wiring exits the conduit to prevent damage.
- E. Properly support and run in a neat workmanlike manner all wiring and conduit. Run parallel to or at a right angle to building structure.
- F. Number-code or color-code conductors, excluding those used for individual zone controls, appropriately for future identification and servicing of control system.
- G. This section shall provide all line voltage power wiring required because of substitution of equipment specified in this section.
- H. Install raceways, boxes, and cabinets according to Division 26 Section "Raceway and Boxes for Electrical Systems".
- I. Install line voltage wiring in rigid conduit.
- J. Install wire and cable according to Division 26 Section "Low-Voltage Electrical Power Conductors and Cables".
- K. Install signal and communication cable according to Division 27 Section "Communications Horizontal Cabling".
  - 1. Bundle and harness multi-conductor instrument cable in place of single cables where several cables follow a common path.

2. Fasten flexible conductors, bridging cabinets and doors, along hinge side; protect against abrasion. Tie and support conductors.
3. Number-code or color-code conductors for future identification and service of control system, except local individual room control cables.
4. Install wire and cable with sufficient slack and flexible connections to allow for vibration of piping and equipment.

### 3.6 FIELD QUALITY CONTROL

- A. Manufacturer's Field Service: Engage a factory-authorized service representative to inspect field-assembled components and equipment installation, including connections. Report results in writing.
- B. Perform the following field tests and inspections and prepare test reports:
  1. Operational Test: After electrical circuitry has been energized, start units to confirm proper unit operation. Remove and replace malfunctioning units and retest.
  2. Test and adjust controls and safeties.
  3. Test each point through its full operating range to verify that safety and operating control set points are as required.
  4. Test each control loop to verify stable mode of operation and compliance with sequence of operation. Adjust PID actions.
  5. Test each system for compliance with the existing sequences of operation.
  6. Test software and hardware interlocks.
- C. Controls Verification:
  1. Check dampers. Verify that proper blade alignment, either parallel or opposed, has been provided.
  2. Check control system as follows:
    - a. Verify that controller power supply is from emergency power supply.
    - b. Verify that wires at control panels are tagged with their service designation and approved tagging system.
    - c. Verify that spare I/O capacity has been provided.
    - d. Verify that controllers are protected from power supply surges.
- D. Replace damaged or malfunctioning controls and equipment and repeat testing procedures.

### 3.7 ADJUSTING

- A. Calibrating and Adjusting:
  1. Calibrate instruments.
  2. Make three-point calibration test for both linearity and accuracy for each analog instrument.
  3. Calibrate equipment and procedures using manufacturer's written recommendations and instruction manuals. Use test equipment with accuracy at least double that of instrument being calibrated.
  4. Control System Inputs and Outputs:
    - a. Check digital inputs using jumper wire.
    - b. Check digital outputs using ohmmeter to test for contact making or breaking.
    - c. Check resistance temperature inputs at 0, 50, and 100 percent of span using a precision-resistant source.
  5. Stroke and adjust control valves and dampers without positioners, following the manufacturer's recommended procedure, so that valve or damper is 100 percent open and closed.
  6. Stroke and adjust control valves and dampers with positioners, following manufacturer's recommended procedure, so that valve and damper is 0, 50, and 100 percent closed.

7. Provide diagnostic and test instruments for calibration and adjustment of system.
8. Provide written description of procedures and equipment for calibrating each type of instrument. Submit procedures review and approval before initiating startup procedures.

END OF SECTION

THIS PAGE INTENTIONALLY LEFT BLANK

**SECTION 23 09 93 - SEQUENCE OF OPERATIONS FOR HVAC CONTROLS**

**PART 1 - GENERAL**

**1.1 RELATED DOCUMENTS**

- A. The Drawings and General Provisions of the Contract, including General and Supplementary Conditions and Division 01 Specification Sections, apply to the Work in this Section.

**1.2 SUMMARY**

- A. Control sequence is hereby defined to mean the manner in which, and methods by which, the controls function. The requirements for each type of operation are specified in this section.

**1.3 QUALITY ASSURANCE**

- A. Use adequate numbers of skilled workers who are thoroughly trained and experienced in the necessary crafts and who are completely familiar with the specified requirements and the methods needed for proper performance of the work of this Section.
- B. Without additional cost to the Owner, provide such other labor and materials as are required to complete the work of this Section in accordance with the requirements of governmental agencies having jurisdiction, regardless of whether such materials and associated labor are called for elsewhere in these Contract Documents.

**PART 2 – PRODUCTS (Not Used)**

**PART 3 - SEQUENCE OF OPERATIONS**

**2.1 GENERAL**

- A. All HVAC systems shall be controlled with stand-alone, Direct Digital Control (DDC) as provided by each equipment manufacturer. Additional points or software programming not listed in the following sequence of operation but are documented on the Drawings shall be provided.

**2.2 VRV AIR HANDLING UNITS**

- A. For each air handling unit the thermostat time-of-day programmable schedule shall start and stop the supply air fan through the HOA in the starter. When the fan starts, the minimum outside air damper shall open.
- B. The constant volume units, except the detention air handling units, shall be controlled by a programmable thermostat located as indicated on the plans. Detention air handling units shall be controlled by the unit's control system.
- C. Smoke detectors furnished and wired by Division 28 in the supply and return air of the unit shall, upon detection of smoke, de-energize the supply fan.

- D. The fan discharge high pressure cut-out switch located on the discharge side of the supply fan to prevent damage to air handler housing and ducting, with an AFS-460 Cleveland switch with manual reset (field adjustable). Should the limit be exceeded, the supply air fan shall be shut down. High pressure cut-out switch requires manual reset.

### 2.3 DETENTION/LOCK-UP AREA VRV AIR HANDLING UNITS

- A. For each air handling unit the thermostat time-of-day programmable schedule shall start and stop the supply air fan through the HOA in the starter. When the fan starts, the minimum outside air damper shall open.
- B. Temperature shall be maintained in the space via a remote averaging thermostat for each dayroom with the thermostat located in control room.
- C. Division 28 shall furnish and wire smoke detectors in the supply and return air ducts of the unit. On a signal from the Fire Alarm system either from the duct smoke detectors or from a smoke zone alarm, the DDC Controller shall operate in a fire/smoke mode.
- D. The fan discharge high pressure cut-out switch located on the discharge side of the supply fan to prevent damage to air handler housing and ducting, with an AFS-460 Cleveland switch with manual reset (field adjustable). Should the limit be exceeded, the supply air fan shall be shut down, the outside air damper shall close. High pressure cut-out switch requires manual reset.

### 2.4 VARIABLE REFRIGERANT VOLUME HEAT PUMP/HEAT RECOVERY

- A. The DDC system shall monitor and control each split system fan coil.
- B. A wired controller for each fan coil shall have the following features:
  - Operation
    - Start/Stop
    - Operation Mode
    - Temperature Setting
    - 60°F-90°F Set Point Range
    - Fan Speed
  - Status
    - Status
    - Malfunction Flashing
    - Malfunction Content
    - Filter Sign
    - Operation Mode
    - Temperature Setting
    - Permit/Prohibit Selection
    - Fan Speed
  - Scheduling
    - ON/OFF Timer
  - Control Management
    - Field Setting Mode
    - Group Setting
    - Auto Re-Start
- C. The space served by the split system is controlled in Occupied and Unoccupied modes as follows:
  - 1. In Occupied mode the fan is on, the DDC controller stages the cooling and heating in sequence to maintain the room temperature set point.



2. In Unoccupied mode the split system is controlled using the Unoccupied space temperature set point. The unit fan is off when the space temperature is between the heating and cooling Unoccupied set points. The controller may reset to the Occupied mode for a predetermined time period upon a signal from the control system or manually at the room sensor.

**2.5 APPARATUS BAY EXHAUST FAN.**

- A. The Apparatus bay fan shall have a timer switch adjustable from 1-60 minutes mounted 48" AFF at a location directed by the architect and the owner to allow for manual operation. The switch shall open an outside air in-take damper. An end switch on the damper shall start the Apparatus Bay Exhaust Fan. The outside air in-take damper shall be closed and the exhaust fan shall stop when the time is complete.
- B. CO sensor and NO2 sensor shall be located at a height as recommended by the manufacturer in location indicated on the plans or by the architect.
- C. In the auto position, the fan shall operate in the following manner. On sensing a CO or NO2 level above set point (adjustable), the relay shall open an outside air in-take damper. An end switch on the damper shall start the Apparatus Bay Exhaust Fan. On the sensing an acceptable CO or NO2 level, the outside air-intake damper shall be closed and the exhaust fan shall stop. The fans shall also be interlocked to the garage door motors. When the garage door motors are powered down to a closed position the fans shall be energized and run for 15 minutes (adjustable).

**2.6 SALLY PORT/VEHICLE PROCESSING EXHAUST FAN**

- A. The fan shall have an H-O-A switch mounted 48" AFF at a location as directed by the architect and owner.
- B. In the auto position, the fan shall operate in the following manner. On sensing a CO or NO2 levels above set point (adjustable) or a call for cooling (T-stat set at 85°F adj.), the relay shall open an outside air in-take damper. An end switch on the damper shall start the exhaust fan. On the sensing an acceptable CO or NO2 levels or space set point at 83°F or less for 15 minutes, the outside air in-take damper shall be closed and the exhaust fan shall stop. The fans shall also be interlocked to the garage door motors. When the garage door motors are powered the fans shall be energized and run for 15 minutes after the garage door motors are engaged to close. Signal CO or NO2 shall override T-stat signal for system operation. Provide a 15 minute delay relay on fan starts to prevent rapid cycling.
- C. In the hand position, the fan shall operate in the following manner. The relay shall open an outside air in-take damper. An end switch on the damper shall start the exhaust fan. The outside air in-take damper shall be closed and the exhaust fan shall stop when the H-O-A switch is placed in the Off or Auto position.

**2.7 SMOKE PURGE FAN**

- A. Automatic Smoke Purge mode:
  1. On a signal from the Fire Alarm system either from the duct smoke detectors or from a smoke zone alarm, the unit shall operate in a fire/smoke mode through a series of relays. The normal return air, and supply air dampers shall close and the supply fan shall be de-energized to protect the unit, the smoke supply air and smoke exhaust air damper shall open and the smoke exhaust and supply fan

shall run. Upon detection of smoke in the supply air or return air duct, the unit and smoke purge fan shall continue to operate in its fire/smoke mode.

- B. Manual Smoke Purge mode:
  - 2. Provide wall mounted rotary type push button in central control (unless noted otherwise) which shall activate the smoke purge mode. This switch shall allow for manual or automatic mode of operation. It shall not be able to disable the smoke purge system.

## 2.8 MANUAL PURGE FANS

- A. Provide wall mounted mushroom type push button adjacent to door (unless noted otherwise) which shall activate the air side economizer mode for 10 minutes (adj.) regardless of ambient conditions. Cooling or heating systems shall be enabled to try to maintain mode of operation room temperature set point.

## 2.9 DETENTION/LOCK-UP AREA SMOKE MAKE-UP AND EXHAUST FANS

- A. The DDC Controller shall monitor the Fire Alarm System. On a smoke zone alarm from the fire alarm panel, the DDC Controller shall start the Make-up Air and Exhaust Fans for that zone as indicated in the control sequence in the plans. The air handling unit serving the zone in alarm shall be de-energized. The air handling unit serving the adjacent smoke zones in alarm shall remain in operation to prevent the migration of smoke.
- B. The smoke zone shall have a two position switch for automatic and manual located in central control. This allows for manual purge of any smoke zone.

## 2.10 GENERAL EXHAUST FANS

- A. The exhaust fans serving one rooms shall start and stop with a motion sensor interlocked with the light fixtures.
- B. Each exhaust fan in detention areas shall run continuously.

## 2.11 ELECTRICAL INTERLOCKS

- A. Provide electrical interlocks as listed herein, in other sections of these specifications and as noted in the equipment schedules.
- B. Electrical interlocks shall be made by means of auxiliary contacts on motor starters or shall be accomplished with separate relays unless indicated otherwise. No motor power lead shall be utilized in an interlock circuit, unless indicated otherwise. Each separate control power lead serving a starter shall be provided with a disconnecting switch suitably identified and housed, which may be a toggle switch or other suitable disconnecting device, of proper capacity and number of poles.

**END OF SECTION**

## SECTION 23 29 23 - VARIABLE-FREQUENCY MOTOR CONTROLLERS

### PART 1 - GENERAL

#### 1.1 RELATED DOCUMENTS

- A. Drawings and general provisions of the Contract, including General and Supplementary Conditions and Division 01 Specification Sections, apply to this Section.

#### 1.2 SUMMARY

- A. Section includes separately enclosed, pre-assembled, combination VFDs, rated 600 V and less, for speed control of three-phase, squirrel-cage induction motors.

#### 1.3 DEFINITIONS

- A. BAS: Building automation system.
- B. CPT: Control power transformer.
- C. EMI: Electromagnetic interference.
- D. IGBT: Insulated-gate bipolar transistor.
- E. LAN: Local area network.
- F. LED: Light-emitting diode.
- G. MCP: Motor-circuit protector.
- H. NC: Normally closed.
- I. NO: Normally open.
- J. OCPD: Over current protective device.
- K. PCC: Point of common coupling.
- L. PID: Proportional plus integral plus derivative.
- M. PWM: Pulse-width modulated.
- N. RFI: Radio-frequency interference.
- O. TDD: Total demand (harmonic current) distortion.
- P. THD(V): Total harmonic voltage distortion.
- Q. VFD: Variable frequency drive (motor controller).

#### 1.4 SUBMITTALS

- A. Provide submittals as required in section 23 00 10, "Submittal Process".**
- B. Product Data: For each type and rating of VFD indicated. Include features, performance, electrical ratings, operating characteristics, shipping and operating weights, and furnished specialties and accessories.

- C. Shop Drawings: For each VFD indicated. Include dimensioned plans and elevations indicating conduit entry locations and sizes, mounting arrangements, details and required clearances and service space around equipment.
    - 1. Show tabulations of installed devices, equipment features, and ratings. Include the following:
      - a. Each installed unit's type and details.
      - b. Factory-installed devices.
      - c. Enclosure types and details.
      - d. Nameplate legends.
      - e. Short-circuit current (withstand) rating of enclosed unit.
      - f. Features, characteristics, ratings, and factory settings of each VFD and installed devices.
      - g. Specified modifications.
    - 2. Schematic and Connection Wiring Diagrams: For power, signal, and control wiring.
  - D. Harmonic Analysis Study and Report.
  - E. Coordination Drawings: Floor plans, drawn to scale, showing dimensioned layout, required working clearances, and required area above and around VFDs. Show VFD layout and relationships between electrical components and adjacent structural and mechanical elements. Show support locations, type of support, and weight on each support. Indicate field measurements.
  - F. Qualification Data: For qualified testing agency.
  - G. Seismic Qualification Certificates: For VFDs, accessories, and components, from manufacturer.
    - 1. Basis for Certification: Indicate whether withstand certification is based on actual test of assembled components or on calculation.
    - 2. Detailed description of equipment anchorage devices on which the certification is based, and their installation requirements.
  - H. Product Certificates: For each VFD, from manufacturer that includes factory test reports.
  - I. Source quality-control reports.
  - J. Field quality-control reports.
  - K. ISO 9000 certificate.
  - L. Operation and Maintenance Data: For VFDs to include in emergency, operation, and maintenance manuals. In addition to items specified in Division 01 Section "Operation and Maintenance Data," include the following:
    - 1. Manufacturer's written instructions for testing and adjusting thermal-magnetic circuit breaker and MCP trip settings.
    - 2. Manufacturer's written instructions for setting field-adjustable overload relays.
    - 3. Manufacturer's written instructions for testing, adjusting, and reprogramming microprocessor control modules.
    - 4. Manufacturer's written instructions for setting field-adjustable timers, controls, and status and alarm points.
  - M. Load-Current and List of Settings of Adjustable Overload Relays: Compile after motors have been installed and arrange to demonstrate that switch settings for motor-running overload protection suit actual motors to be protected.
- 1.5 QUALITY ASSURANCE
- A. Testing Agency Qualifications: UL and/or ETL listed and labeled.
    - 1. Tested to UL-508A.
    - 2. Plenum rated applications: Tested to UL-508C.

- B. Electrical Components, Devices, and Accessories: Listed and labeled as defined in NFPA 70, by a qualified testing agency, and marked for intended location and application.
- C. Comply with NFPA 70.
- D. Harmonic Analysis Study and Report: Comply with IEEE Standard 399 and NETA Acceptance Testing Specification.
  - 1. The VFD manufacturer shall provide calculations; specific to this installation, showing total harmonic voltage distortion is less than 5%. Input filters shall be sized and provided as required by the VFD manufacturer to ensure compliance with IEEE Standard 519. Trap filters shall not be an acceptable means of reducing harmonic distortion.
  - 2. Calculations shall use the building electrical service entrance as the point of common coupling.
  - 3. VFD manufacturer shall request in writing the following:
    - a. Electrical one-line diagram identifying all VFDs and transformers.
    - b. Transformers (including utility transformer) upstream of VFDs.
      - 1) kVA.
      - 2) % impedance.
      - 3) Primary and secondary voltages.
      - 4) Feeder size and approximate length.
    - c. Schedule of all existing and new VFDs.
      - 1) Voltage.
      - 2) Phases.
      - 3) Horsepower.
      - 4) Feed size and approximately length.
- E. Manufacturer is ISO 9000 certified.
- F. Local service representative's requirements:
  - 1. Provide and maintain field service personnel authorized by Manufacturer to perform service both in and out of warranty.
  - 2. Maintain full stock of service parts for all units furnished.
  - 3. Provide in-depth training in operation of all units.
- G. IEEE Compliance: Fabricate and test VFD according to IEEE 344 to withstand seismic forces defined in Division 26 Section "Vibration and Seismic Controls for Electrical Systems."

## 1.6 WARRANTY

- A. Special Warranty: Manufacturer's standard form in which manufacturer agrees to repair or replace VFDs that fail in materials or workmanship within specified warranty period.
  - 1. Warranty Period: Five (5) years on all parts and labor from date of Substantial Completion.

## PART 2 - PRODUCTS

### 2.1 MANUFACTURED UNITS

- A. Acceptable Manufacturers: Subject to compliance with requirements, provide products by one of the following:
  - 1. ABB.
  - 2. Danfoss Inc.; Danfoss Drives Div.
  - 3. Yaskawa Electric America, Inc; Drives Division.
  - 4. Toshiba International Corporation.
- B. General Requirements for VFDs: Comply with NEMA ICS 7, NEMA ICS 61800-2, and UL 508C.

VFD Description: Variable-frequency power converter (rectifier, dc bus, and IGBT, PWM inverter) factory packaged in an enclosure, with integral disconnecting means and overcurrent and overload protection; listed and labeled by an NRTL as a complete unit; arranged to provide self-protection, protection, and variable-speed control of one or more three-phase induction motors by adjusting output voltage and frequency.

1. Units suitable for operation of NEMA MG 1, Design A and Design B motors as defined by NEMA MG 1, Section IV, Part 30, "Application Considerations for Constant Speed Motors Used on a Sinusoidal Bus with Harmonic Content and General Purpose Motors Used with Adjustable-Voltage or Adjustable-Frequency Controls or Both."
  2. Units suitable for operation of inverter-duty motors as defined by NEMA MG 1, Section IV, Part 31, "Definite-Purpose Inverter-Fed Polyphase Motors."
  3. Listed and labeled for integrated short-circuit current (withstand) rating by an NRTL acceptable to authorities having jurisdiction.
- C. Design and Rating: Match load type, such as fans, blowers, and pumps; and type of connection used between motor and load such as direct or through a power-transmission connection.
- D. Output Rating: Three-phase; 0 to 120 Hz, with voltage proportional to frequency throughout voltage range; maximum voltage equals input voltage.
- E. Unit Operating Requirements:
1. Input AC Voltage Tolerance: Plus 10 and minus 10 percent of VFD input voltage rating.
  2. Input AC Voltage Unbalance: Not exceeding 3 percent.
  3. Input Frequency Tolerance: Plus or minus 3 percent of VFD frequency rating.
  4. Minimum Efficiency: 99 percent at 60 Hz, full load.
  5. Minimum Displacement Primary-Side Power Factor: 98 percent under any load or speed condition.
  6. Minimum Short-Circuit Current (Withstand) Rating: 65 kAIC unless noted otherwise on the Drawings. VFD shall be able to withstand in-rush from re-engaging service disconnect between VFD and motor.
- F. Rate equipment for continuous operation, capable of driving full load without derating, under the following conditions unless otherwise indicated:
1. Ambient Temperature Rating: Not less than 14 deg F and not exceeding 104 deg F.
  2. Ambient Storage Temperature Rating: Not less than minus 4 deg F and not exceeding 140 deg F
  3. Humidity Rating: Less than 95 percent (non-condensing).
  4. Altitude Rating: Not exceeding 3300 feet.
  5. Vibration Withstand: Comply with IEC 60068-2-6.
  6. Overload Capability: 1.5 times the base load current for 60 seconds; minimum of 1.8 times the base load current for three seconds.
  7. Starting Torque: Minimum 100 percent of rated torque from 3 to 60 Hz.
  8. Speed Regulation: Plus or minus 5 percent.
  9. Output Carrier Frequency: Selectable throughout the following range: 2 to 12 kHz.
  10. Stop Modes: Programmable; includes fast, free-wheel, and dc injection braking.
  11. Exception: VFDs whose output current is derated for any of the above conditions shall be sized based on those derated values.
- G. Inverter Logic: Microprocessor based, isolated from all power circuits.
- H. Internal Adjustability Capabilities:
1. Minimum Speed: 5 to 25 percent of maximum rpm.
  2. Maximum Speed: 80 to 100 percent of maximum rpm.
  3. Acceleration: 0.1 to 999.9 seconds.
  4. Deceleration: 0.1 to 999.9 seconds.
  5. Current Limit: 30 to minimum of 150 percent of maximum rating.

- I. Self-Protection and Reliability Features:
  - 1. Input transient protection by means of surge suppressors to provide three-phase protection against damage from supply voltage surges 10 percent or more above nominal line voltage.
  - 2. Loss of Input Signal Protection: Selectable response strategy, including speed default to a percent of the most recent speed, a preset speed, or stop; with alarm.
  - 3. Under- and overvoltage trips.
  - 4. Inverter overcurrent trips.
  - 5. VFD and Motor Overload/Overtemperature Protection: Microprocessor-based thermal protection system for monitoring VFDs and motor thermal characteristics, and for providing VFD overtemperature and motor overload alarm and trip; settings selectable via the keypad; NRTL approved.
  - 6. Critical frequency rejection, with three selectable, adjustable deadbands.
  - 7. Instantaneous line-to-line and line-to-ground overcurrent trips.
  - 8. Loss-of-phase protection.
  - 9. Reverse-phase protection.
  - 10. Short-circuit protection.
  - 11. Motor overtemperature fault.
- J. Automatic Reset/Restart: Attempt a minimum of three restarts after drive fault or on return of power after an interruption and before shutting down for manual reset or fault correction; adjustable delay time between restart attempts.
- K. Torque Boost: Automatically varies starting and continuous torque to at least 1.5 times the minimum torque to ensure high-starting torque and increased torque at slow speeds.
- L. Motor Temperature Compensation at Slow Speeds: Adjustable current fall-back based on output frequency for temperature protection of self-cooled, fan-ventilated motors at slow speeds.
- M. Integral Input Disconnecting Means and OCPD: NEMA AB 1, instantaneous-trip circuit breaker with pad-lockable, door-mounted handle mechanism.
  - 1. Disconnect Rating: Not less than 115 percent of NFPA 70 motor full-load current rating or VFD input current rating, whichever is larger.

## 2.2 CONTROLS AND INDICATION

- A. Status Lights: Door-mounted LED indicators displaying the following conditions:
  - 1. Power on.
  - 2. Run.
  - 3. Overvoltage.
  - 4. Line fault.
  - 5. Overcurrent.
  - 6. External fault.
- B. Panel-Mounted Operator Station: Manufacturer's standard front-accessible, sealed keypad and plain-English language digital display; allows complete programming, program copying, operating, monitoring, and diagnostic capability.
  - 1. Keypad: In addition to required programming and control keys, include keys for HAND, OFF, and AUTO modes.
  - 2. Security Access: Provide electronic security access to controls through identification and password with at least three levels of access: View only; view and operate; and view, operate, and service.
    - a. Control Authority: Supports at least four conditions: Off, local manual control at VFD, local automatic control at VFD, and automatic control through a remote source.

3. VFD Parameters: Ability to scroll and display in plain English language the following parameters:
  - a. Output frequency (Hz).
  - b. Motor speed (rpm).
  - c. Motor status (running, stop, fault).
  - d. Motor current (amperes).
  - e. Motor torque (percent).
  - f. Fault or alarming status (code).
  - g. PID feedback signal (percent).
  - h. DC-link voltage (V dc).
  - i. Set point frequency (Hz).
  - j. Motor output voltage (V ac).
- C. Historical Logging Information and Displays:
  1. Real-time clock with current time and date.
  2. Running log of total power versus time.
  3. Total run time.
  4. Fault log, maintaining last four faults with time and date stamp for each.
- D. Control Signal Interfaces:
  1. Electric Input Signal Interface:
    - a. A minimum of two, programmable analog inputs: 4 to 20 mA or 0 to 10 V.
    - b. A minimum of six, multifunction, programmable digital inputs.
  2. Output Signal Interface: A minimum of one programmable analog output signal(s) (4 to 20 mA), which can be configured for any of the following:
    - a. Output frequency (Hz).
    - b. Output current (load).
    - c. DC-link voltage (V dc).
    - d. Motor torque (percent).
    - e. Motor speed (rpm).
    - f. Set point frequency (Hz).
  3. Remote Indication Interface: A minimum of two programmable dry-circuit relay outputs (120 V, 1 A) for remote indication of the following:
    - a. Motor running.
    - b. Set point speed reached.
    - c. Fault and warning indication (overtemperature or overcurrent).
    - d. PID high- or low-speed limits reached.

## 2.3 LINE CONDITIONING AND FILTERING

- A. Output DC Reactors: Unless noted otherwise provide 5% impedance reactors for VFDs whose cable lengths between VFD and motor exceed 100 ft.
- B. Input Line Conditioning: Based on the harmonic analysis study and report, provide input filtering, as required, to limit TDD at input terminals of all VFDs to less than 5 percent and THD(V) to 3 percent.

## 2.4 BYPASS SYSTEMS

- A. General: Provide manual bypass as specified herein for VFDs scheduled for motors serving single fan or single pump systems only.
- B. Bypass Operation: Safely transfers motor between power converter output and bypass circuit, manually, automatically, or both. Selector switches set modes and indicator lights indicate mode selected. Unit is capable of stable operation (starting, stopping, and running) with motor completely disconnected from power converter.



- C. Bypass Controller: Three-contactor-style bypass allows motor operation via the power converter or the bypass controller; with input isolating switch and barrier arranged to isolate the power converter input and output and permit safe testing and troubleshooting of the power converter, both energized and de-energized, while motor is operating in bypass mode.
1. Bypass Contactor: Load-break, IEC-rated contactor.
  2. Input and Output Isolating Contactors: Non-load-break, IEC-rated contactors.
  3. Isolating Switch: Non-load-break switch arranged to isolate power converter and permit safe troubleshooting and testing of the power converter, both energized and de-energized, while motor is operating in bypass mode; pad-lockable, door-mounted handle mechanism.
- D. Bypass Contactor Configuration: Full-voltage (across-the-line) type.
1. NORMAL/BYPASS selector switch.
  2. HAND/OFF/AUTO selector switch.
  3. NORMAL/TEST Selector Switch: Allows testing and adjusting of VFD while the motor is running in the bypass mode.
  4. Contactor Coils: Pressure-encapsulated type with coil transient suppressors.
    - a. Operating Voltage: Depending on contactor NEMA size and line-voltage rating, manufacturer's standard matching control power or line voltage.
    - b. Power Contacts: Totally enclosed, double break, and silver-cadmium oxide; assembled to allow inspection and replacement without disturbing line or load wiring.
  5. Control Circuits: 120-V ac; obtained from integral CPT, with primary and secondary fuses, with CPT of sufficient capacity to operate all integral devices and remotely located pilot, indicating, and control devices.
    - a. CPT Spare Capacity: 50 VA.
  6. Overload Relays: NEMA ICS 2.
    - a. Melting-Alloy Overload Relays:
      - 1) Inverse-time-current characteristic.
      - 2) Class 10 tripping characteristic.
      - 3) Heaters in each phase matched to nameplate full-load current of actual protected motor and with appropriate adjustment for duty cycle.
    - b. Bimetallic Overload Relays:
      - 1) Inverse-time-current characteristic.
      - 2) Class 10 tripping characteristic.
      - 3) Heaters in each phase matched to nameplate full-load current of actual protected motor and with appropriate adjustment for duty cycle.
      - 4) Ambient compensated.
      - 5) Automatic resetting.
    - c. Solid-State Overload Relays:
      - 1) Switch or dial selectable for motor-running overload protection.
      - 2) Sensors in each phase.
      - 3) Class 10 tripping characteristic selected to protect motor against voltage and current unbalance and single phasing.
      - 4) Class II ground-fault protection, with start and run delays to prevent nuisance trip on starting.
      - 5) Analog communication module.
    - d. NC isolated overload alarm contact.
    - e. External overload reset push button.
  7. Motor protection from single phase power conditions: The Bypass system must be able to detect a single phase input power condition while running in bypass, disengage the motor in a controlled fashion, and give a single phase input power indication.
  8. The system (VFD and Bypass) tolerated voltage window shall allow the system to operate from a line voltage of +30% to -35% nominal voltage, as a minimum. The system shall incorporate circuitry that will allow the drive or bypass contactor to remain "sealed in" over this voltage tolerance at a minimum.

9. The Bypass system shall NOT depend on the VFD for bypass operation. The bypass shall be completely functional in both Hand and Automatic modes even if the VFD has been removed from the enclosure for repair / replacement.
10. Serial Communications: The bypass and VFD shall be capable of being monitored and/or controlled via serial communications as specified herein.
  - a. BACnet Serial communication bypass capabilities shall include, but not be limited to; bypass run-stop control; the ability to force the unit to bypass; and the ability to lock and unlock the keypad. The bypass shall have the capability of allowing the DDC to monitor feedback such as, bypass current (in amps), bypass kilowatt hours (resettable), bypass operating hours (resettable), and bypass logic board temperature. The DDC shall also be capable of monitoring the bypass relays output status, and all digital input status. "Pass thru I/O" All bypass diagnostic warning and fault information shall be transmitted over the serial communications bus. Remote bypass fault reset shall be possible. The following additional bypass status indications and settings shall be transmitted over the serial communications bus – keypad "Hand" or "Auto" selected, and bypass selected. The DDC system shall also be able to monitor if the motor is running under load in both VFD and bypass (proof of flow) in the VFD mode over serial communications or Form C relay output. A minimum of 40 field parameters shall be capable of being monitored in the bypass mode.
11. Run permissive circuit - There shall be a run permissive circuit for damper or valve control. Regardless of the source of a run command (keypad, time-clock control, or serial communications) the VFD and bypass shall provide a dry contact closure that will signal the damper to open (VFD motor does not operate). When the damper is fully open, a normally open dry contact (end-switch) shall close. The closed end-switch is wired to a VFD system input and allows motor operation. Two separate safety interlock inputs shall be provided. When either safety is opened, the motor shall be commanded to coast to stop, and the damper shall be commanded to close.
12. The bypass control shall monitor the status of the VFD and bypass contactors and indicate when there is a welded contactor contact or open contactor coil. This failed contactor operation shall be indicated on the Bypass LCD display as well as over the serial communications protocol.
13. The bypass control shall include a programmable time delay for bypass start and keypad indication that this time delay is in process. This will allow VAV boxes to be driven open before the motor operates at full speed in the bypass mode. The time delay shall be field programmable from 0 – 120 seconds.
14. The bypass control shall be programmable for manual or automatic transfer to bypass. The user shall be able to select via keypad programming which drive faults will generate an automatic transfer to bypass and which faults require a manual transfer to bypass.
15. There shall be an adjustable motor current sensing circuit for the bypass and VFD mode to provide proof of flow indication. The condition shall be indicated on the keypad display, transmitted over the building automation protocol and on a relay output contact closure.
16. The bypass controller shall have six programmable digital inputs, and five programmable form C relay outputs.
17. The relay outputs from the bypass shall be programmable for any of the following indications.
  - a. System started.
  - b. System running.
  - c. Bypass override enabled.
  - d. Drive fault.
  - e. Bypass fault.
  - f. Bypass H-O-A position.
  - g. Motor proof of flow (broken belt).
  - h. Overload.
  - i. Bypass selected.

- j. Bypass run.
  - k. System started (damper opening).
  - l. Bypass alarm.
  - m. Over temperature.
18. The digital inputs for the system shall accept 24VAC or 24VDC. The bypass shall incorporate internally sourced power supply and not require an external control power source. The bypass power board shall supply 250 mA of 24 VDC for use by others to power external devices.
19. Customer Interlock Terminal Strip – provide a separate terminal strip for connection of freeze, fire, smoke contacts, and external start command. All external safety interlocks shall remain fully functional whether the system is in VFD or Bypass mode. The remote start/stop contact shall operate in VFD and bypass modes. The terminal strip shall allow for independent connection of up to four (4) unique safety inputs.
20. The user shall be able to select the text to be displayed on the keypad when the safety opens. Example text display indications include “Firestat”, “Freezstat”, “Over pressure” and “Low pressure”. The user shall also be able to determine which of the four (4) safety contacts is open over the serial communications connection.
21. Class 10, 20, or 30 (selectable) electronic motor overload protection shall be included.
22. Phase-Failure, Phase-Reversal, and Undervoltage and Overvoltage Relays: Solid-state sensing circuit with isolated output contacts for hard-wired connections. Provide adjustable undervoltage, overvoltage, and time-delay settings.]

## 2.5 OPTIONAL FEATURES

- A. Multiple-Motor Capability: VFD suitable for variable-speed service to multiple motors. Overload protection shuts down VFD and motors served by it, and generates fault indications, when overload protection activates.
- 1. Configure to allow two or more motors to operate simultaneously at the same speed; separate overload relay for each controlled motor.
  - 2. Configure to allow two motors to operate separately; operator selectable via local or remote switch or contact closures; single overload relay for both motors; separate output magnetic contactors for each motor.
  - 3. [Configure to allow two motors to operate simultaneously and in a lead/lag mode, with one motor operated at variable speed via the power converter and the other at constant speed via the bypass controller; separate overload relay for each controlled motor.]
- B. Damper control circuit with end of travel feedback capability.
- C. Sleep Function: Senses a minimal deviation of a feedback signal and stops the motor. On an increase in speed-command signal deviation, VFD resumes normal operation.
- D. Remote digital operator kit.

## 2.6 ENCLOSURES

- A. Provide enclosures for each application listed below unless otherwise scheduled.
- B. VFD Enclosures: NEMA 250, to comply with environmental conditions at installed location.
- 1. Dry and Clean Indoor Locations: Type 1.
  - 2. Outdoor Locations: Type 3R.
  - 3. Other Wet or Damp Indoor Locations: Type 4.
  - 4. Indoor Locations Subject to Dust, Falling Dirt, and Dripping Noncorrosive Liquids: Type 12.
- C. Plenum Rating: UL 1995; NRTL certification label on enclosure, clearly identifying VFD as "Plenum Rated."

## 2.7 ACCESSORIES

- A. General Requirements for Control-Circuit and Pilot Devices: NEMA ICS 5; factory installed in VFD enclosure cover unless otherwise indicated.
  - 1. Push Buttons, Pilot Lights, and Selector Switches: Standard-duty, oil tight type.
    - a. Push Buttons: Covered types; maintained.
    - b. Pilot Lights: LED type.
    - c. Selector Switches: Rotary type.
- B. Control Relays: Auxiliary and adjustable solid-state time-delay relays.
- C. Phase-Failure, Phase-Reversal, and Undervoltage and Overvoltage Relays: Solid-state sensing circuit with isolated output contacts for hard-wired connections. Provide adjustable undervoltage, overvoltage, and time-delay settings.

### **PART 3 - EXECUTION**

#### **3.1 DELIVERY, STORAGE, AND HANDLING**

- A. Store loose VFDs per manufacturer's recommendations. Keep packing secured and all VFD components free from contact with construction dust, dirt and debris.
- B. Cover and protect from dust, dirt and debris through the entire construction process. Do not remove cover until startup.
- C. Protect unit mounted VFDs during delivery from damage.

#### **3.2 EXAMINATION**

- A. Examine areas, surfaces, and substrates to receive VFDs, with Installer present, for compliance with requirements for installation tolerances, and other conditions affecting performance.
- B. Examine VFD before installation. Reject VFDs that are visibly damaged, wet, moisture damaged, or mold damaged.
- C. Examine roughing-in for conduit systems to verify actual locations of conduit connections before VFD installation.
- D. Notify the Owner, in writing, of any conditions detrimental to the proper and timely completion of the Work.
- E. Proceed with installation only after unsatisfactory conditions have been corrected.

#### **3.3 COORDINATION**

- A. Coordinate features of motors, load characteristics, installed units, and accessory devices to be compatible with the following:
  - 1. Torque, speed, and horsepower requirements of the load.
  - 2. Ratings and characteristics of supply circuit and required control sequence.
  - 3. Ambient and environmental conditions of installation location.
- B. Coordinate sizes and locations of concrete bases with actual equipment provided. Cast anchor-bolt inserts into bases.
- C. Coordinate sizes and locations of roof curbs, equipment supports, and roof penetrations with actual equipment provided.
- D. Coordinate with DDC Contractor as necessary to integrate controls.
- E. Interruption of Existing Electrical Systems: Do not interrupt electrical systems in facilities occupied by Owner or others unless permitted under the following conditions and then only after arranging to provide temporary electrical service according to requirements indicated:

1. Notify Architect, Construction Manager and Owner no fewer than two weeks in advance of proposed interruption of electrical systems.
  2. Indicate method of providing temporary electrical service.
  3. Do not proceed with interruption of electrical systems without Architect's, Construction Manager's or Owner's written permission.
  4. Comply with NFPA 70E.
- F. Drawings indicate maximum dimensions for VFDs, including clearances between VFDs, and adjacent surfaces and other items.

### 3.4 INSTALLATION

- A. Coordinate layout and installation of VFDs with other construction including conduit, piping, equipment and adjacent surfaces. Maintain required workspace clearances and required clearances for equipment access doors and panels.
- B. Install VFD where shown in accordance with manufacturer's written instructions, and with recognized industry practices, to ensure that VFD complies with requirements and serve intended purposes.
- C. Maintain required code and service clearances in front of and around VFDs.
- D. Install units on pad mounts or on wall as shown. Mount on properly sized supports and bracing sized to handle the VFD load and mounting configuration. Do not mount on AHU unless indicated so on the drawings or in the specifications.
- E. Wall-Mounted Controllers: Install VFDs on walls with tops at uniform height and with disconnect operating handles not higher than 48 inches above finished floor unless otherwise indicated, and by bolting units to wall or mounting on lightweight structural-steel channels bolted to wall. For controllers not on walls, provide freestanding racks complying with Division 26 Section "Hangers and Supports for Electrical Systems".
- F. Floor-Mounted Controllers: Install VFDs on 4-inch nominal thickness concrete base. Comply with requirements for concrete base specified in Division 03 Section "Cast-in-Place Concrete."
1. Install dowel rods to connect concrete base to concrete floor. Unless otherwise indicated, install dowel rods on 18-inch centers around the full perimeter of concrete base.
  2. For supported equipment, install epoxy-coated anchor bolts that extend through concrete base and anchor into structural concrete floor.
  3. Place and secure anchorage devices. Use setting drawings, templates, diagrams, instructions, and directions furnished with items to be embedded.
  4. Install anchor bolts to elevations required for proper attachment to supported equipment.
- G. Roof-Mounted Controllers: Install VFD on roofs with tops at uniform height and with disconnect operating handles not higher than 48 inches above finished roof surface unless otherwise indicated, and by bolting units to curbs or mounting on freestanding, lightweight, structural-steel channels bolted to curbs. Seal roof penetrations after raceways are installed.
1. Curbs and roof penetrations are specified in Division 07 Section "Roof Accessories."
  2. Structural-steel channels are specified in Division 26 Section "Hangers and Supports for Electrical Systems."
- H. Seismic Bracing: Comply with requirements specified in Division 26 Section "Vibration and Seismic Controls for Electrical Systems."
- I. Temporary Lifting Provisions: Remove temporary lifting eyes, channels, and brackets and temporary blocking of moving parts from enclosures and components.
- J. Install fuses in each fusible-switch VFD.
- K. Install fuses in control circuits if not factory installed. Comply with requirements in Division 26 Section "Fuses."

- L. Install, connect, and fuse thermal-protector monitoring relays furnished with motor-driven equipment.
- M. Install electrical connections for power, controls, and devices.
- N. Ground equipment according to Division 26 Section "Grounding and Bonding for Electrical Systems."
- O. Connect wiring according to Division 26 Section "Low-Voltage Electrical Power Conductors and Cables."

### 3.5 IDENTIFICATION

- A. Identify VFDs, components, and control wiring. Comply with requirements for identification specified in Division 26 Section "Identification for Electrical Systems."
  - 1. Identify field-installed conductors, interconnecting wiring, and components; provide warning signs.
  - 2. Label each VFD with engraved nameplate.
  - 3. Label each enclosure-mounted control and pilot device.
- B. Operating Instructions: Frame printed operating instructions for VFDs, including control sequences and emergency procedures. Fabricate frame of finished metal, and cover instructions with clear acrylic plastic. Mount on front of VFD units.

### 3.6 CONTROL WIRING INSTALLATION

- A. Install wiring between VFDs and remote devices and facility's Building Automation System. Comply with requirements in Division 26 Section "Control-Voltage Electrical Power Cables."
- B. Bundle, train, and support wiring in enclosures.
- C. Connect selector switches and other automatic control devices where applicable.
  - 1. Connect selector switches to bypass only those manual- and automatic control devices that have no safety functions when switches are in manual-control position.
  - 2. Connect selector switches with control circuit in both manual and automatic positions for safety-type control devices such as low- and high-pressure cutouts, high-temperature cutouts, and motor overload protectors.

### 3.7 SOURCE QUALITY CONTROL

- A. Testing: Test and inspect VFDs according to requirements in NEMA ICS 61800-2.
  - 1. Test each VFD while connected to its specified motor.
  - 2. Verification of Performance: Rate VFDs according to operation of functions and features specified.
- B. VFDs will be considered defective if they do not pass tests and inspections.
- C. Prepare test and inspection reports.

### 3.8 FIELD QUALITY CONTROL

- A. Testing Agency: Engage a qualified testing agency to perform tests and inspections.
- B. Acceptance Testing Preparation:
  - 1. Test insulation resistance for each VFD element, bus, component, connecting supply, feeder, and control circuit.
  - 2. Test continuity of each circuit.
- C. Tests and Inspections:

1. Inspect VFD, wiring, components, connections, and equipment installation. Test and adjust controllers, components, and equipment.
  2. Test insulation resistance for each VFD element, component, connecting motor supply, feeder, and control circuits.
  3. Test continuity of each circuit.
  4. Verify that voltages at VFD locations are within 10 percent of motor nameplate rated voltages. If outside this range for any motor, notify Architect, Construction Manager and Owner before starting the motor(s).
  5. Test each motor for proper phase rotation.
  6. Perform each electrical test and visual and mechanical inspection stated in NETA Acceptance Testing Specification. Certify compliance with test parameters.
  7. Correct malfunctioning units on-site, where possible, and retest to demonstrate compliance; otherwise, replace with new units and retest.
  8. Test and adjust controls, remote monitoring, and safeties. Replace damaged and malfunctioning controls and equipment.
- D. VFDs will be considered defective if they do not pass tests and inspections.
- E. Prepare test and inspection reports, including a certified report that identifies the VFD and describes scanning results. Include notation of deficiencies detected, remedial action taken, and observations made after remedial action.
- 3.9 STARTUP SERVICE
- A. Engage a factory-authorized service representative to perform startup service.
1. Complete installation and startup checks according to manufacturer's written instructions.
- 3.10 ADJUSTING
- A. Program microprocessors for required operational sequences, status indications, alarms, event recording, and display features. Clear events memory after final acceptance testing and prior to Substantial Completion.
- B. Set field-adjustable switches, auxiliary relays, time-delay relays, timers, and overload-relay pickup and trip ranges.
- C. Set the taps on reduced-voltage autotransformer controllers.
- D. Set field-adjustable circuit-breaker trip ranges as specified in Division 26 Section "Overcurrent Protective Device Coordination Study."
- E. Set field-adjustable pressure switches.
- 3.11 PROTECTION
- A. Replace VFDs whose interiors have been exposed to water or other liquids prior to Substantial Completion.
- 3.12 DEMONSTRATION & TRAINING
- A. Engage a factory-authorized service representative to train Owner's maintenance personnel to adjust, operate, reprogram, and maintain VFDs.
- B. Training of Owner's operating personnel shall be on site and shall be a minimum of eight hours and shall be performed in addition to start-up of system.

**END OF SECTION**

**THIS PAGE INTENTIONALLY LEFT BLANK**



SECTION 23 31 13 – AIR DISTRIBUTION

PART 1 - GENERAL

1.1 RELATED DOCUMENTS

- A. The Drawings and General Provisions of the Contract, including General and Supplementary Conditions and Division 01 Specification Sections, apply to the Work in this Section.

1.2 SUMMARY

- A. Provide all equipment, materials, labor, supervision and services necessary for or incidental to the installation of all air distribution items as indicated on the drawings and as specified.
- B. Work Included:
  - 1. Ductwork.
  - 2. Access Doors.

1.3 QUALITY ASSURANCE

- A. Use adequate numbers of skilled workmen who are thoroughly trained and experienced in the necessary crafts and who are completely familiar with the specified requirements and the methods needed for proper performance of the work of this Section.
- B. Without additional cost to the Owner, provide such other labor and materials as are required to complete the work of this Section in accordance with the requirements of governmental agencies having jurisdiction, regardless of whether such materials and associated labor are called for elsewhere in these Contract Documents.
- C. When requested, provide the Architect with manufacturer's certificate that materials and methods meet or exceed minimum requirements as specified.
- D. **Under no circumstances shall OBD's or butterfly dampers be used on any registers. In accessible areas manual dampers shall be used. In hard lid ceiling areas, remote cable dampers shall be used. Access panels shall not be used to access any damper in a hard lid ceiling.**
- E. Mechanical rooms and Electrical rooms shall not be used as return air plenums. Hard duct OSA & R/A directly into FCU's.
- F. **Return Air, Exhaust, Air Make-up & OSA ducts shall be steel duct work connections. Flexible duct shall not be used for these types of terminations.**
- G. Exterior Duct & Serviceability
  - 1. Exterior duct shall have a minimum 18" clearance from the roof deck.
  - 2. Provide engineered stamped & OSHA approved steps over duct to easily access all areas of the roof.

1.4 SUBMITTALS

- A. **Provide submittals as required in section 23 00 10, "Submittal Process."**

PART 2 - PRODUCTS

2.1 SHEET METAL DUCTWORK

- A. Ducts shall be constructed of new-galvanized steel sheets and erected in a first class manner, straight and smooth, with joints neatly finished, anchored securely to the building and free from vibration.
- B. All ducts penetrating fire walls shall be minimum **26-gauge** galvanized steel regardless of SMACNA Standards.
- C. All elbows shall be curved elbows with a centerline radius equal to 1-1/2 times the width of the duct. Air turns consisting of curved metal vanes, arranged to permit the air to follow abrupt turns without appreciable turbulence shall be installed in square elbows, only where approved by the engineer. Air turns shall be the manufacturer's standard products, and shall be quiet and free from vibration.
- D. All primary and secondary ductwork of constant volume, shall be fabricated in accordance with the Sheet Metal and Air Conditioning Contractor's National Association, Inc. (SMACNA) "HVAC Duct Construction Standards, Metal and Flexible, Second Edition, 2005". The duct static pressure rating for this duct shall be two times the external static pressure of the system fan. The requirements for the seal class corresponding to the above static pressure shall be met.
- E. Longitudinal joints shall be Pittsburgh lock or Acme grooved seam. Side panels greater than 10 inches in depth shall be cross-broken for added stiffness.
- F. **Transverse joints (With a side wall larger than 14") shall be Ductmate, TDC or types fabricated according to SMACNA's "HVAC Duct Construction Standards - Metal and Flexible" Figure 1-4, "Transverse (Girth) Joints," for static-pressure class, applicable sealing requirements, materials involved, duct-support intervals, and other provisions in SMACNA's "HVAC Duct Construction Standards - Metal and Flexible."**
- G. **Round steel duct shall be spiral duct construction in all commercial applications. Snap lock round duct is acceptable in residential construction only.**
- H. At each major branch from a primary rectangular or square trunk duct, and where shown on the drawings, install a splitter damper or multiblade adjustable air pickup. Splitter damper shall have end bearings and consist of a blade constructed of 20 gauge-galvanized steel securely riveted or welded to a square operating rod. The length of the splitter blade shall be 1-1/2 times the width of the split in the main duct, but in no case less than 12". Multi-blade adjustable pickup shall be as manufactured by Titus Model AG-45 or approved equal with operator adjustable from the duct exterior.
- I. Each individual air supply duct tap shall be equipped with a volume control device for the manual adjustment of airflow in each tap. Face bars, blanks, OBD's and equalizing grids shall not be used to regulate airflow.
- J. **Exposed duct shall use Fantech IR Series manual control dampers.** No substitutes.
- K. Volume dampers shall have end bearings and be multi-blade type with opposed acting

blades linked together and controlled by a single operator. Multi-blade dampers shall be not less than No. 16-gauge galvanized steel mounted to plenum or ductwork per SMACNA requirements.

- L. Regulators shall be stamped galvanized steel, lever type with locking screw mounted on face of ductwork or concealed type with adjustable cover plate as manufactured by Young Regulator Model No. 315 with 2-1/4" diameter cover plate or approved equal.
- M. Dampers handles shall be extended so the damper is not obstructed by any insulation and easily adjustable.
- N. Damper quadrants, volume dampers and other duct flow control quadrants shall be as manufactured by Young Regulator or approved equal and shall be damper sleeves.
- O. For all areas where damper adjustments cannot be accessed through the ceiling, Bowden cable controls shall be used. Damper controller and cable shall be concealed above the ceiling. Cable shall consist of Bowden cable 0.054" stainless steel control wire encapsulated with 1/16" flexible galvanized spiral wire sheath. Control kit shall consist of 270-896 bracket with a 7/8" diameter cold rolled steel zinc plated threaded cap suitable for painting, and 14 gauge steel rack and pinion gear drive converting rotary motion to push-pull motion. Control shafts shall be D-style flatted 1/4" diameter with 265 degree rotation providing graduations for positive locking and control, and 1-1/2" linear travel capability. Control kit shall be manually operated using Young Regulator Model 030-12 wrench. Provide a wrench for each cable control system installed. Control kit shall be Young Regulator Model 270-896P with tamper proof screws or prior approval equal.
- P. On the inlet and outlet of each piece of air moving equipment or terminal unit, unless noted otherwise, install a flexible connection made with sufficient slack to render it flexible.
- Q. Furnish and install 24-gauge galvanized steel counter flashings for all ducts penetrating roofs and for all roof mounted equipment unless directed otherwise by the Architect.
- R. All duct penetrations through the floor to another level must be sealed with 24-gauge sheet metal fastened to the floor and duct sealing the hole. No open areas are acceptable. All Standards for penetrations through floors and fire safety must be followed.
- S. All exposed duct shall be fabricated with paint grip duct and shall be painted with 2 coat primer and 2 coat gloss paint. Color to be chosen by owner.

## 2.2 PRE-INSULATED HVAC DUCTWORK SYSTEM (Contractors Alternate)

- A. Pre-Insulated HVAC Ductwork System: Provide Kingspan KoolDuct System for supply, return, fresh-air and exhaust air duct as shown in the contract drawings. System shall include panels, fabrication methods, coupling systems, and accessories to provide a complete system to meet the following performance criteria.
  - 1. Classification: UL listed as a Class 1 Air Duct, to UL 181, NFPA 90A and NFPA 90B.
  - 2. Fire & Smoke Performance must meet ASTM E84 or UL 723.
    - b. Flame Spread <=25
    - c. Smoke Developed <=50
  - 3. Materials: CFC/HCFC free, zero Ozone Depletion Potential, fiber free rigid thermoset phenolic insulation core faced with 1mil low vapor permeability aluminum

- foil reinforced with glass scrim.
4. Nominal Density: 3.4 to 3.75 pcf (55 to 60 kg/m<sup>3</sup>).
  5. Closed Cell Content: minimum 90 percent
  6. Compressive Strength: Minimum 29 psi (200 kPa) at 10 percent compression.
  7. Air Leakage: SMACNA Air Leakage Class 3.
  8. Mean Air Velocity Maximum 5000 fpm (25.4 m/s) with all joints sealed.
  9. Design Pressures:
    - a. Positive Pressure: Maximum 4 inch w.g. (1000 Pa).
    - b. Negative Pressure: Maximum 3 inch w.g. (750 Pa).
  10. Commissioning Pressures - As designed to, max commissioning 4 inch w.g. (1000Pa.).
  11. Temperature Range: Internal air temperature range -15 to 185 deg. F (-26 to 85 C) during continuous operation, inside ducts or ambient surrounding temperature.
  12. Thermal Resistance, Wall Thickness and R-Value:
    - a. 7/8 inch (22 mm) thick, R 6.0 square feet per hour F/Btu (1.047 square meter K/W).
    - b. 1-3/16 inch (30 mm) thick, R 8.1 square feet per hour F/Btu (1.428 square meter K/W).
    - c. 1-1/8 inch (32 mm) thick, R 10.0 square feet per hour F/Btu (1.774 square meter K/W).
    - d. 1-25/32 inch (45mm) thick, R 12 square feet per hour F/Btu (2.15 square meter K/W).
    - e. 1-1/4 inch (32 mm) thick, R 10.0 square feet per hour F/Btu (1.774 square meter K/W).
  13. Thermal Conductivity: at 50 to 74 deg. F (10 to 23 deg C), mean 0.146 Btu inch per square foot per hour deg. F (0.021 W/m K) per ASTM C518.
  14. Typical Configuration: Rectangular.

#### **B. ACCESSORIES**

1. Fittings: In accordance with SMACNA Phenolic Duct Construction Standards or the ASHRAE Design Fundamentals Handbook Chapter 35 or the SMACNA HVAC Duct Systems Design Manual.2.
2. Support Systems: Tiger Support and Wire Hanger Assembly. Steel Channel Support and Threaded Rods.
3. Coupling System: Tiger Clip Coupling System. Aluminum Grip Coupling System. 4-Bolt Coupling System.
4. Access Doors: Metal insulated access doors. Fabricated from the Kingspan KoolDuct System including the same insulation system, and to ensure a continuous vapor barrier.
5. Turning Vanes
6. V-Groove Sealant: Silicone with VOC content of 250 g/L or less.

#### **C. FABRICATION**

1. Fabricate ductwork with panels, joints, seams, transitions, reinforcements, supports, elbows, connections, and accessories in accordance with SMANCA Phenolic Duct Construction Standards and the manufacturer guidelines.
  - a. 90 degree mitered elbows shall include turning veins.
  - b. Interior Ductwork: Standard finish.
  - c. Exterior Ductwork: Dual-Tech pre-fabricated, double layer ducting system.
    1. Inner layer shall be R-8 Kingspan KoolDuct
    2. Outer layer shall be R-8 Kingspan KoolDuct
    3. Exterior layer shall be .032 aluminum.

**2.3 EXTERIOR DUCTWORK**

- A. Exterior duct system shall be Dual-Tech system, by PTM Manufacturing, LLC. Newark, DE, 19713. (302) 455-9733. PTM design guidelines shall be strictly adhered too. Duct work shall be Double Wall Kingspan KoolDuct encased with PTM beaded and silicone sealed white .032 Aluminum. Or Approved equal.
  
- B. In other Part 2 articles where titles below introduce lists, the following requirements apply to product selection:
  - 1. Available Manufacturers: Subject to compliance with requirements, manufacturers offering products that may be incorporated into the Work include, but are not limited to, manufacturers specified.
  - 2. Manufacturers: Subject to compliance with requirements, provide products by one of the manufacturers specified.
  
- C. Outdoor Ductwork Insulation Material:
  - 1. Duct work shall be double wall R8 (30mm) Kingspan KoolDuct. The panels used in the fabrication of Dual-Tech ductwork from the Kingspan KoolDuct System shall be Kingspan KoolDuct rigid phenolic insulation panels of nominal dimensions 12.89 ft x 3.94 ft and minimum compressive strength 29 psi, as manufactured by Kingspan Insulation Ltd and detailed in App. A1.
  - 2. Kingspan KoolDuct rigid phenolic insulation panels shall comprise a 3.4–3.75 pcf nominal density CFC/HCFC–free rigid phenolic insulation core with zero Ozone Depletion Potential (ODP), autohesively bonded on both sides to a 1 mil low vapor permeability aluminum foil facing reinforced with a 0.2” glass scrim.
  - 3. Kingspan KoolDuct rigid phenolic insulation panels are available in thicknesses of 1 3/16” (R-8.1 ft<sup>2</sup>.hr.<sup>o</sup>F/Btu), as per design Thermal Requirements for double wall and a combined R16 thermal value.
  - 4. All other components required for the fabrication of ductwork from the Kingspan KoolDuct System including the silicone sealant, contact adhesive, aluminum tape, self–adhesive gasket, ductwork reinforcements, closures, connectors and flanges shall be as approved / supplied by Kingspan Insulation Ltd.
  - 5. Weather barrier shall be fabricated of mill finished white aluminum sheeting, 0.032” in thickness. Exposed seems to be covered with 1” butyl and a 8” embossed aluminum beaded bands, secured with #10 self tapping, stainless screws with weather seal washers.
  - 6. At weather barrier abutment locations, an industrial grade RTV silicone caulk shall beutilized, where applicable.
  - 7. Seams exposed to the weather shall be covered and sealed with a 1” wide by 1/8” thick butyl compound.
  - 8. All screws utilized to fasten panel system together shall be #10 x 1/2” self-tapping, stainless steel, weather seal washer screws painted white.
  - 9. Contact cement or 2-sided adhesive tape shall be utilized for laminating insulation material to the weather barrier sheeting.
  - 10. 8. Foil tape used for sealing the insulation edges shall be a minimum thickness of 1.25 mil.

**C. Fabrication**

1. Sizing: Panel system shall be sized in four overlapping sections to provide a complete seal surrounding KoolDuct ducting. Shall be laminated to the weather barrier and sized to allow for sufficient overlap as indicated in section 3.0 above. Second wall ducting shall be adhered utilizing appropriate contact method.
  2. Where feasible all general fabrication shall be performed in the shop and be based off of approved project drawing or direct field measurements.
  3. Field fabrication should be limited to routing and sealing of the ducting sections to allow for duct angle, supports, gauges or other duct related necessities. All routed areas shall be resealed with appropriate foil faced cast tape. No insulation/phenolic material shall be exposed to the environment.
- D. Fire & Smoke Performance
1. The rigid phenolic insulation panels used in the fabrication of KoolTech ductwork and / or ductwork sections fabricated from the Kingspan KoolDuct System shall achieve the following fire and smoke performance requirements:
    - a. ASTM E 84-08a – unfaced or composite (insulation, facing and adhesive) of low contribution to fire growth not exceeding 25 Flame Spread and 50 Smoke Developed indices;
    - b. UL 723 – unfaced or composite (insulation, facing and adhesive) of low contribution to fire growth not exceeding 25 Flame Spread and 50 Smoke Developed indices; and
    - c. UL 181 – UL/ULC classification as a Class 1 Air Duct to NFPA Standards 90A & 90B.
- E. Sealants
1. All internal seams must be fully sealed with an unbroken layer of silicone sealant.
  2. Each ductwork section must be duly connected with a jointing system approved Kingspan Insulation Ltd., and sufficient silicone sealant should be applied in order to seal the rigid phenolic insulation panel and ensure minimum air leakage.
  3. Ductwork reinforcement, if necessary, shall be applied to protect against side deformation from both positive and negative pressure.
  4. All external seams where two separate panels join must be taped to achieve a permanent bond and a smooth wrinkle free appearance.
- F. Hangers & Supports
1. Building Attachments: Concrete inserts, powder-actuated fasteners, or structural-steel fasteners appropriate for construction materials to which hangers are being attached.
    - a. Use powder-actuated concrete fasteners for standard-weight aggregate concretes or for slabs more than 4 inches (100 mm) thick.
    - b. Exception: Do not use powder-actuated concrete fasteners for lightweight-aggregate concretes or for slabs less than 4 inches (100 mm) thick.
  2. Hanger Materials: Galvanized sheet steel or threaded steel rod.
    - a. Hangers Installed in Corrosive Atmospheres: Electrogalvanized, all-thread rods or galvanized rods with threads painted with zinc-chromate primer after installation.

- b. Strap and Rod Sizes: Comply with SMACNA's "HVAC Duct Construction Standards—Metal and Flexible" for steel sheet width and thickness and for steel rod diameters.
- c. Galvanized-steel straps attached to aluminum ducts shall have contact surfaces painted with zinc-chromate primer.

#### 2.4 FLEXIBLE DUCTWORK

- A. Core material shall be a PVC Coated Fiberglass reinforced fabric supported by helically wound galvanized steel. The fabric shall be mechanically fastened to the steel helix without the use of adhesive.
- B. The internal working pressure rating shall be at least as follows with a bursting pressure of at least 2-1/2 times the working pressure.
- C. The duct shall be rated for a velocity of at least 5500 feet per minute.
- D. Suitable for operating temperatures of at least 250 degrees F.
- E. Factory insulate the flexible duct with flexible fiberglass insulation. The R value shall be at least 6.0 at a mean temperature of 75 degrees F. (R4.2 not acceptable)
- F. Cover the insulation with a reinforced aluminum pigmented vapor barrier jacket having a permeance of not greater than 0.05 perms when tested in accordance with ASTM E 96, procedure A.
- G. The ductwork shall be UL 181 listed, Class 1 Air Duct and comply with NFPA 90A and NFPA 90B.
- H. Duct shall be secured with metal bands no less than 1.5" wide.
- I. Duct shall be Flexmaster Type 8M or pre-approved equal

#### 2.5 ACCESS DOORS

- A. Provide access doors equal to Nailor-Hart Ind., Inc. Series 0800.
- B. Access doors are not permitted in public areas of buildings.

#### 2.6 FIRE AND SMOKE DAMPERS

- A. Provide combination fire and smoke dampers where shown on the drawings. Dampers shall meet all requirements of fire dampers and additionally shall include an operating shaft, which, when rotated 90 deg., causes the damper to operate between closed and open. All dampers shall comply with the requirements of UL-555S, 350°F temperature rating and with pressure and velocity levels as required by the installation. Provide breakaway duct connects as required by UL.
- B. **Each damper shall be provided with an end switch.**
- C. **Each damper shall have a duct door within 6" of the outlet of each damper. The minimal size duct door shall be no less 8x8.**

- D. Each damper shall be furnished complete with 18 gauge galvanized factory sleeve and damper operator (pneumatic or electric to conform to control system) factory installed on exterior of sleeve and properly linked to damper operating shaft. Operators shall be UL listed and labeled as Fire Damper Operators.
- E. Each damper shall be activated by a duct smoke detector provided by Division 26.
- F. Dampers shall be as manufactured by Ruskin, Nailor-Hart or approved equal.
- G. Wiring
  - 1. Each smoke zone shall be wired on a separate circuit.
    - a. Each fire/smoke damper shall be wired on a separate circuit in each designated zone.
    - b. Each smoke damper for make-up air shall be wired on a separate circuit in each designated zone, separate from the fire/smoke damper and the exhaust damper.
    - c. Each smoke damper for smoke exhaust shall be wired on a separate circuit in each designated zone, separate from the fire/smoke damper and make-up air damper.

**2.7 KITCHEN GREASE EXHAUST DUCTWORK**

- A. The kitchen grease exhaust ductwork shall be constructed of black steel not less than 16 ga. up to 4 sq. ft. area, 14 ga. above 4 sq. ft. or as required by local codes with continuous grease-tight and water-tight welds at all joints and seams.
- B. The system shall be so constructed that no grease will become pocketed in any portion thereof and shall slope at not less than that prescribed by local codes, back to the hood. Where permitted by local codes, provide approved duct grease residue trap when minimum slopes are not provided due to restricted clearance.
- C. Openings in duct shall conform to code requirements and shall be provided for complete and thorough cleaning of duct system.
- D. Air velocity in the duct shall be not less than 1500 fpm nor more than 2500 fpm.
- E. Connection to hood shall be made above the finished ceiling unless shown otherwise on the drawings.
- F. All connections to fans shall be bolted flanged type and shall be gasketed with a resilient gasket not less than 3/8" thick, for fume-tight seal and for vibration absorption. Gasket shall be of a material impervious to grease and be NPFA approved as fire and leak proof.
- G. All kitchen hood exhaust ducts shall have fire rated duct wrap or enclosure as required to meet all code requirements. Method shall be approved by governing authorities having jurisdiction prior to installation.

**PART 3 - EXECUTION**

**3.1 INSTALLATION - METAL DUCTS**

- A. All ductwork shall be installed as recommended by SMACNA and as shown or indicated on the drawings. Coordinate ductwork with all other trades and elements of the building construction.



- B. All ductwork accessories shall be provided as specified or shown or indicated on the drawings, install as recommended by SMACNA and the manufacturer.
- C. Ductwork shall be installed in a neat, workmanlike manner with ducts generally parallel to structure and tops of ducts as high as possible against building construction. Provide offsets as necessary to avoid obstructions, piping, or structural members, It is contractors responsibility to communicate with other trades to reduce the amount of offsets needed. The additional cost of offsets and fittings shall not be passed onto the owner.
- D. Flexible ductwork shall be installed and supported as recommended by SMACNA and the manufacturer. Refer to section 2.4 for more details.
- E. At each major branch from a primary rectangular or square trunk duct, and where shown on the drawings, install a splitter damper or multi-blade adjustable air pickup. Refer to section 2.1 for requirements.
- F. Volume dampers shall be installed within ducts or plenums where shown on the drawings and on all supply/return/exhaust taps for balancing of system.
- G. **All Dampers shall be marked with a flag for easy identification of location.**
- H. Round or oval ductwork shall be fastened together with a minimum of three sheet metal screws equally spaced around the perimeter of the duct and taped with an approved duct sealing tape. Ductwork shall be furnished complete with all factory fabricated starting collars, Y shaped branch takeoffs, adjustable elbows, etc.
- I. Where ducts are in mechanical rooms or unfinished areas, or where dampers occur above lift out ceilings, regulators shall be stamped galvanized steel, lever type with locking screw mounted on face of ductwork. For all other areas, where damper adjustments cannot be accessed through the ceiling, regulators shall be the concealed type with adjustable cover plate.
- J. On the inlet and outlet of each piece of air moving equipment, unless noted otherwise, install a flexible connection made with sufficient slack to render it flexible.
- K. Where air intakes and/or discharges are indicated on the drawings and no air device is indicated, install 1/4" bird screens over each duct opening set in galvanized steel frames and securely attach to the openings.
- L. Provide concentric taps on all connections from the main duct to branch ducts.
- M. Provide stamped steel duct access doors at each fire damper, fire and smoke damper, where control devices occur within ductwork, and as indicated on the drawings. Access doors shall be fully insulated where duct is lined internally. Provide with mounting flange, double thickness door with cam latch, gasket and retaining wire. No tools shall be required to open the access door.
- N. The minimum size of each access door shall be sufficient to provide adequate access for the intended purpose of installation.

3.2 INSTALLATION SECTION 2.2 – (Contractors Alternate)

- A. Clean & Prepare surfaces using methods recommended by the manufacturer.

- B. Install in accordance with manufacturer's instructions using the fewest joints as possible.
- C. Support: Installer is responsible to ensure duct system is properly and adequately supported using materials that are compatible with the duct system, with supports typically located in straight runs, changes in direction, branch connections, tee fittings, and with SMANCA practices.
- D. Install joint sections in accordance with SMANCA Phenolic Duct Construction Standards.
- E. Tape External seams to ensure a permanent, smooth, wrinkle-free bond
- F. Apply Kingspan silicone sealant at each internal seam to ensure minimum air leakage.

### 3.3 FIELD QUALITY CONTROL

- A. Commissioning: Include testing and verification of functional and operational performance at intended pressure and temp ranges, training for operations maintenance and documentation. Commissioning test pressure shall not exceed the pressure rating to which the ductwork has been designed and fabricated.
- B. Air Leakage Testing: Test in accordance with ASHRAE 90.1 and with SMANCA HVAC Air Duct Leakage Test Manual, including operation at static pressure on at least 25 percent of the total installed duct area.

### 3.4 DUCT SEALING

- A. All exposed duct shall be internally sealed, or gasket sealed fittings shall be used.**
  - 1. Duct sealer on exposed joints will not be acceptable.
- B. All seams, joints and taps must be sealed with a water and air tight sealant.
- C. Sealer must be a Water Based Duct Sealer designed for use in high velocity air conditioning, refrigeration, ventilating, and air distributing systems up to 15w.g.. It must be suitable for use in both indoor and outdoor applications and exceeds all SMACNA Pressure and Sealing Classes.
  - 1. Duct tape and Foil tape is not an approved sealer.

**END OF SECTION**

**SECTION 23 05 29 - PIPE HANGERS AND SUPPORTS FOR HVAC PIPING AND EQUIPMENT**

PART 1 - GENERAL

1.1 RELATED DOCUMENTS

- A. The Drawings and General Provisions of the Contract, including General and Supplementary Conditions and Division 01 Specification Sections, apply to the Work in this Section

1.2 SUMMARY

- A. Provide all equipment, materials, labor, supervision, and services necessary for or incidental to the installation of all necessary identification items as indicated on the drawings and as specified.
- B. Contractor shall field verify and coordinate all ductwork hangers and supports, dimensions, clearances, and ductwork elevations with new and existing building structures.
- C. Submittals: Provide submittals as required in Section 23 05 00 "Common Work Results for HVAC".

1.3 QUALITY ASSURANCE

- A. Use adequate numbers of skilled workmen who are thoroughly trained and experienced in the necessary crafts and who are completely familiar with the specified requirements and the methods needed for proper performance of the work of this Section.
- B. Without additional cost to the Owner, provide such other labor and materials as are required to complete the work of this Section in accordance with the requirements of governmental agencies having jurisdiction, regardless of whether such materials and associated labor are called for elsewhere in these Contract Documents.
- C. All duct shall be installed in a quality workmanship. Ductwork shall be straight and level.
- D. Methods of supporting ductwork shall be in accordance with the SMANCA Manual, Section 1 – Low Velocity Systems, unless otherwise shown on the drawings or specifications herein.
- E. SMANCA – Sheet Metal and Air Conditioning Contractors National Association Inc.
- F. Electrically operated and power actuated tools for installing welded studs and power driven fasteners, shall be listed by a nationally recognized testing agency.

1.4 SUBMITTALS

- A. **Provide submittals as required in section 23 00 10, "Submittal Process."**

1.5 RELATED WORK SPECIFIED ELSEWHERE

- A. 23 31 13: Air Distribution
- B. 23 07 00: HVAC Insulation

PART 2 - PRODUCTS

2.1 PIPE HANGERS AND SUPPORTS

- A. Type 1: Hangers shall be rod type hangers: Mild Carbon steel, unless otherwise specified: fully threaded with (2) removeable nuts on each end for positioning and locking rod in place. Rods must be galvanized or Cadmium plated.
- B. Type 2: 1"-1.5" 24 gage galvanized strap. Strap must be fastened to SMANCA standards.
- C. Type 3: Dyna-Tite Suspension system: Using aviation grade galvanized wire rope and cable locks. This application shall only be acceptable for round exposed duct.
- D. Hangers for ducts shall be as specified in the SMANCA Manual, with the following exceptions.
  - 1. Lower hanger attachments for rectangular duct with any dimensions 36" wide and above shall be trapeze hangers, supported by minimal 3/8 threaded galvanized rod.
  - 2. Trapeze hangers shall be a minimum 1-1/2 x 1-1/2 x 1/4" angle or 1-5/8 Unistrut larger size as required by larger or heavier ductwork.
  - 3. Lower hanger attachments for rectangular duct maximum dimensions less than 30" 24 gage flat strap attached directly to duct. Fasteners penetrating duct must be completely sealed.
  - 4. Wire used as supports or as banding shall not be acceptable.
  - 5. Threaded support rods shall utilize sufficient support, jamb, and lock nuts to allow adjustment for duct heights.
- E. **Exposed duct hangers shall be: Duct Mate Round duct hangers, Model: GRDM4703GA or similar.**

2.2 MISCELLANIOUS FASTENERS AND UPPER HANGER ATTACHMENTS

- A. Machine Bolts and Nuts: Galvanized or cadmium plated steel.
- B. Steel "C" clamps with lock nuts. Elcen Co. No. 29L, with 25B steel retaining clips.
- C. Hilti KH-EZI All-thread concrete screw anchor
- D. Hilti HMN nail in anchor.
- E. Hilti HDI-P Threaded rod expansion fitting.
- F. Sheet metal fasteners shall be a minimum #10x3/4 sheet metal screw.

2.3 BRANCH FITTINGS, JOINTS & TURNING VANES

- A. Provide supports necessary for lengths over 16" or heights over 8".

PART 3 - EXECUTION

3.1 UPPER HANGER ATTACHMENTS

- A. General Note: Upper hanger attachments for ductwork shall be secured to overhead structural steel or steel bar joists wherever possible, unless otherwise specified.
- B. When required by ductwork support spacing schedules, provide intermediate structural steel members, framed to span the structural steel or steel bar joists. The minimum size of structural steel members, for the use of intermediate steel framing, shall be 2-1/2 x 2-1/2 x 1/4" steel angles. Steel members shall be shop primed prior to installation. Intermediate steel shall be sized for span and load to show no deflection.
- C. Secure upper hanger attachments to bar joists at the panel points of joists.
- D. Under no circumstance shall any hole be drilled in structural steel members.
- E. Exercise extreme caution in the field drilling of holes in precast concrete work, to avoid damage to reinforcing. Power driven types of fasteners shall be utilized in the attachment of hangers to precast concrete work.
- F. Upper hanger attachments shall be specified in the manual, with the following exceptions:
1. Do not use flat bar, bent rod, or power activated drive pins as upper hanger attachments in concrete construction. Expansion nails or concrete screws shall be the only approved product.
- G. Attachments to structural steel: Secure to steel beams with beam clamps, welded studs, or "C" clamps with locking nuts and safety bars.
- H. **Under no circumstances shall power activated fasteners be used unless with prior written consent from the Mechanical Engineer's Representative.**
- I. Do not attach welded studs or power activated fasteners to steel less than 3/16" in thickness.
- J. Attachments to Cellular Steel or Fluted Metal Decks: Do not support ductwork from cellular or fluted metal roof decks. Attach hangers to structural steel members wherever possible.
- K. Riser Supports: Support vertical ducts by means of two steel angles or channels, anchor bolted to the floor slab or adjacent structural member at every floor through which the riser passes.
- L. Steel angle or channel support sizes shall be as follows:

<u>Max Side Dimension</u>	<u>Support Angle</u>	<u>Support Channel</u>
36"	1 x 1x 1-1/8	1 x 1/2 x 1/8
48"	1-1/2 x 1-1/2 x 1/8	1-1/2 x 3/4 x 1/8
60"	2 x 2 x 1/8	2 x 1 x 1/8
Over 60"	2-1/2 x 2-1/2 x 3/16	2 x 1 x 3/16

**3.2 DUCT HANGER SPACING**

A. Duct hanger spacing shall be in strict accordance with SMANCA and as follows:

1. Rectangular Duct Hangers Minimum Sizes:

Max. Side of Duct Perimeter	Rod Pair at 10' Spacing	Rod Pair at 8' Spacing	Rod Pair at 4' Spacing
0-72	1/4"	1/4"	1/4"
73-96	3/8"	1/4"	1/4"
97-120	3/8"	3/8"	1/4"
121-168	1/2"	3/8"	3/8"
169-192	1/2"	1/2"	3/8"

2. Round Hanger Strap.

Duct Diameter	Strap Hangers	Max Spacing
4-26	(1) 1" x 22 Ga.	10'
27-36	(1) 1" x 18 Ga.	10'
37-50	(1) 1" x 18 Ga.	10'
51-60	(2) 1" x 18 Ga.	10'

**END OF SECTION**

**SECTION 26 00 10 – ELECTRICAL SUBMITTAL PROCESS**

**PART 1 – GENERAL**

**1.1 SUBMITTALS**

- A. Comply with all submittal provisions of Division 1.
- B. Submit electronic copies of the submittal to the prime consultant (i.e. architect) in order to process and track the submittals properly in accordance with Division 1 and 26 submittal requirements. Architects and consultants are to submit all submittals and RFI's to the mechanical engineer electronically. Send to "**mdengca@md-eng.com**". Submittals shall be labeled by their project specification section or CSI specification section if not listed in project specifications.
- C. Contractor is responsible to separate submittals per specification section. Unseparated submittals are subject to rejection without review.
- D. Allow a minimum of ten (10) working days for the review of submittals and each re-submittal.
- E. Submittals that have been reviewed and marked as REJECTED (REJ) or MAKE CORRECTIONS NOTED (MCN) should be resubmitted within 10 days to be reviewed again by engineer.
- F. Compliance with the Contract documents shall be the sole responsibility of the Contractor. Items on equipment that are were not accepted by the Architect in writing as an approved equal shall be replaced or revised to comply with the contract documents at the Contractor's expense.
- G. Resubmission of rejected submittals shall be limited to one (1) in number. Costs for processing subsequent resubmittals in excess of the first resubmittal, resulting from the Contractor's disregard of Architect/Engineer's primary submittal rejection comments, shall be borne by the Contractor. Costs shall be based on Architect/Engineer's hourly rates as published in their current professional fee schedules and shall also include reimbursable costs for delivery, mailing, and photocopies at direct cost-plus ten percent (10%).

**1.2 REQUIRED SPECIFICATIONS (Project specific)**

- A. The chart below are the submittals required for the project.
  - 1. Submittals marked with an "**X**" are required for this project.
  - 2. Submittals without an "**X**" are not required for this project.

See required specifications on next page

Required X	Submittal Name	Spec Reference
X	<b>Common Work Results for Electrical</b> <i>-Submittals, Shop Drawings.</i>	26 05 00
X	<b>Electrical Demolition</b> <i>-See Specification for information</i>	26 05 01
X	<b>Electrical Work in Existing Facilities</b> <i>-Site Inspection Report</i>	26 05 02
X	<b>Fire Stopping</b> <i>-Materials</i>	26 05 03
X	<b>Low Voltage Electrical Power Conductors</b> <i>-Conductors, Cables</i>	26 05 19
X	<b>Grounding &amp; Bonding</b> <i>-Materials, Chemical ground rod</i>	26 05 26
X	<b>Hangers &amp; Supports for Electrical</b> <i>-Hanger &amp; clamps, Fabricated devices</i>	26 05 29
X	<b>Conduit for Electrical Systems</b> <i>-Conduit &amp; fittings, Supports</i>	26 05 33.13
X	<b>Boxes for Electrical Systems</b> <i>-Boxes, Floor Boxes</i>	26 05 33.16
	<b>Cable Trays for Electrical Systems</b> <i>-Cable Trays</i>	26 05 36
	<b>IN-Floor Walker duct</b> <i>-In-floor Duct Systems</i>	26 05 39
X	<b>Identification for Electrical Systems</b> <i>-Submit all marking systems per spec.</i>	26 05 53
	<b>Overcurrent Protective Device Corr. Study</b> <i>-Final Report</i>	26 05 73
	<b>Electrical Testing</b> <i>-Final Report</i>	26 05 93
X	<b>Disconnect Switches</b> <i>-Manufacturer, Switches, Components</i>	26 06 20
	<b>Lighting &amp; Receptacle (Relay) Panelboards</b> <i>-Product Data per specification</i>	26 09 26
	<b>Lighting Control System</b> <i>-Product Data per Specification</i>	26 09 33
	<b>Occupancy Sensors</b> <i>-Sensor, Shop Drawing for sensor layout.</i>	26 09 23
	<b>Low Voltage Underground Service</b> <i>-Metering Equipment, Raceways &amp; Fittings</i>	26 21 16
	<b>Low Voltage Transformers</b> <i>-Product Data per Specification</i>	26 22 00
	<b>Switchboards</b> <i>-Manufacturer, Bus, Feeder protective devices</i>	26 24 13

Required X	Submittal Name	Spec Reference
	<b>Panelboards</b> <i>-Manufacturer, Panelboards, Distribution</i> <i>-Lighting, Circuit breakers</i>	26 24 16
	<b>Motor Starters</b> <i>-Manufacturer, Manual, Combination</i> <i>-Magnetic</i>	26 24 22
	<b>Tenant Metering</b> <i>-Product Data per Specification</i>	26 25 00
	<b>Electrical Cabinets &amp; Enclosures</b> <i>-Hinged cover enclosures, cabinets, Fab.</i>	26 27 16
	<b>Wiring Devices</b> <i>-Receptacles, Switches, Wall plates</i>	26 27 26
	<b>Enclosed Switches</b> <i>-Components</i>	26 28 16
	<b>Package Engine Generators -Propane</b> <i>-Rating, Engine, Alternators, Controls</i>	26 32 13.11
	<b>Package Engine Generators - NG</b> <i>-Rating, Engine, Alternators, Controls</i>	26 32 13.22
	<b>Diesel Fuel Generator</b> <i>-Rating, Engine, Alternators, Controls</i>	26 22 13.33
	<b>Uninterruptible Power Supply</b> <i>-See Spec for all submittal information</i>	26 33 53
	<b>Automatic Transfer Switch</b> <i>-Transfer Switch</i>	26 36 23
	<b>Quick Disconnect Switch</b> <i>-Heavy-Duty Double Throw Safety Switches</i>	26 36 33
	<b>Facility Lightning Protection</b> <i>-Components</i>	26 41 00
	<b>Surge Protection Devices</b> <i>-General Info, Design, Performance</i> <i>-Testing, Warranty</i>	26 43 00
	<b>Lighting</b> <i>-Shop drawings, Lamps, Fluorescent Ballast</i> <i>-Recessed, lenses, parts.</i>	26 50 00
	<b>Digital Network Lighting Control System</b> <i>-Qualifications, Products, Warranty.</i>	26 50 90
	<b>LED Lighting</b> <i>-Product Data per Specification</i>	26 55 00
	<b>Detention Lighting</b> <i>-Fixtures, components, Security, Ballasts,</i> <i>-Exit signs, Emergency lighting, Lenses,</i>	26 55 63
	<b>Telephone Data-Raceway System</b>	26 55 64



*-Metering, Enclosures, Name plates,*

*-Raceways*

Required X	Submittal Name	Spec Reference
	<b>Disposal of Lamps</b> <i>-Qualifications, Disposal data</i>	26 57 00
	<b>Provisions of Elevators</b> <i>-Qualifications, Power switch module -Pits, Elevator cabs.</i>	26 60 00
	<b>Conduits and Backboxes for Communications</b> <i>-Conduits, Boxes, Raceways.</i>	27 05 23
	<b>Grounding &amp; Bonding for Communications</b> <i>-Product Data per Specification</i>	27 05 26
	<b>Telecom Hangers &amp; Supports</b> <i>-Product Data per Specification</i>	27 05 28
	<b>Cable Trays for Communications</b> <i>-Product Data per Specification</i>	27 05 29
	<b>Comm Cabinet Racks &amp; Enclosures</b> <i>-Product Data per Specification</i>	27 11 16
	<b>Comm Termination Blocks &amp; Patch Panels</b> <i>-Product Data per Specification</i>	27 11 19
	<b>Comm Cable Management &amp; Cable Runway</b> <i>-Product Data per Specification</i>	27 11 23
	<b>Communication Copper Horizontal Cabling</b> <i>-Product Data per Specification</i>	27 15 13

Required X	Submittal Name	Spec Reference
	<b>Communication Faceplates &amp; Connectors</b> <i>-Product Data per Specification</i>	27 15 43
	<b>AV Control Systems &amp; Antenna Systems</b> <i>-Product Data per Specification</i>	27 41 00
	<b>TV Broadband Distribution System</b> <i>-Product Data per Specification</i>	27 41 33
	<b>Sound Systems</b> <i>-Product Data per Specification</i>	27 51 16.13
	<b>Common Work Results for Security System</b> <i>-Shop drawings, Computer equipment, -Grounding, Wiring &amp; Cabling, Raceways -Boxes, Fittings</i>	28 05 10
	<b>Digital Video Manage &amp; Recording System</b> <i>-Product Data per Specification</i>	28 23 00
	<b>Fire Detection &amp; Alarm Systems</b> <i>-FA Control panel, Devices, Detectors, GFCI -Contacts, Grounding, Operations</i>	28 31 10
	<b>Sampling Type Smoke Detector Systems</b> <i>-Detector assembly, Display, Networking,</i>	28 31 11

THIS PAGE INTENTIONALLY LEFT BLANK

**SECTION 26 05 00 - COMMON WORK RESULTS FOR ELECTRICAL**

**PART 1 – GENERAL**

**1.1 RELATED DOCUMENTS**

- A. The Drawings and General Provisions of the Contract, including General and Supplementary Conditions and Division 01 Specification Sections, apply to the Work in this Section.

**1.2 SUMMARY**

- A. General Requirements for Electrical Work are intended to be complementary to General Requirements of Construction Contract.
- B. Work Included: Provide complete electrical systems where shown on Drawings, as specified herein, and as needed for complete and proper installation including, but not necessarily limited to following summary of Work.
  - 1. Interior and exterior lighting
  - 2. Emergency exit and egress lighting
  - 3. Fire detection and alarm system
  - 4. Telephone raceway system
  - 5. Switchboards
  - 6. Lighting and distribution panelboards
  - 7. Power feeds to mechanical, plumbing and fire protection equipment:
    - a. Provide conduit, wire, disconnect switch, overcurrent and short circuit protection for all equipment, whether shown on the drawings or not, including, motorized dampers, smoke dampers, electric heat trace, power for energy management system, water softening equipment, water treatment systems, air dryers, electric flush valves, electric trap primers, electric solenoids, shower valves, and other miscellaneous equipment.
  - 8. Surge protective devices
  - 9. Occupancy sensors
  - 10. Packaged generator set
  - 11. Automatic transfer switch
  - 12. Electrical service entrance
  - 13. Digital control system
  - 14. Other items and services required to complete electrical systems
- C. Rough-in (only) for the video cameras.
- D. Rough-in (only) for the access control system.

**1.3 QUALITY ASSURANCE AND APPLICABLE STANDARDS**

- A. Use adequate numbers of skilled workers thoroughly trained and experienced in necessary crafts and completely familiar with specified requirements and methods needed for proper performance of Work of this Division. Ensure that there is a minimum of one journeyman electrician, on job site whenever Division 26 Work is being performed.

- B. Without additional cost, provide labor and materials as required to complete Work of this Division in accordance with requirements of Governmental Agencies having jurisdiction, regardless of whether materials and associated labor are called for elsewhere in these Contract Documents.
- C. Codes: Electrical and fire alarm work shall conform to requirements and recommendations of the following codes. Refer to the most recent code adopted by the Authority Having Jurisdiction (AHJ).
  - 1. National Electrical Code
  - 2. International Energy Code
  - 3. International Fire Code
  - 4. International Building Code
  - 5. Local amendments to the above codes
- D. Standards: Specifications and Standards of following organizations are by reference made part of these Specifications. Electrical Work, unless otherwise indicated, shall comply with requirements and recommendations wherever applicable:
  - 1. Association of Edison Illuminating Companies (AEIC)
  - 2. American National Standards Institute (ANSI)
  - 3. American Society of Mechanical Engineers (ASME)
  - 4. American Society for Testing and Materials (ASTM)
  - 5. Certified Ballast Manufacturers (CBM)
  - 6. Electrical Testing Laboratories (ETL)
  - 7. Institute of Electrical and Electronic Engineers (IEEE)
  - 8. Insulated Power Cable Engineers Association (IPCEA)
  - 9. National Bureau of Standards (NBS)
  - 10. National Electrical Contractors Association (NECA)
  - 11. National Electrical Manufacturer's Association (NEMA)
  - 12. National Fire Protection Association (NFPA)
  - 13. Radio-Television Manufacturer's Association (RTMA)
  - 14. Reflector Luminaire Manufacturers (RLM)
  - 15. Underwriters' Laboratories, Inc. (UL)

#### 1.4 REQUIREMENTS OF REGULATORY AGENCIES

- A. Requirements and recommendations of latest editions of Occupational Safety and Health Act (OSHA), and Americans with Disabilities Act (ADA), are by reference made part of these Specifications. Work shall comply with requirements and recommendations wherever applicable.

#### 1.5 DEFINITIONS

- A. Terms furnish, install, and provide are used interchangeably and shall mean to furnish and install, complete and ready for intended use.

#### 1.6 SUBMITTALS

- A. Comply with pertinent provisions of Division 01.
- B. Submit electronic copies of the submittal to the prime consultant (i.e. architect) in order to process and track the submittals properly in accordance with Division 1 and 26 submittal requirements. Architects and consultants are to submit all submittals and RFI's to the mechanical engineer electronically. Send to "**mdengca@md-eng.com**". Submittals shall be labeled by their project specification section or CSI specification section if not listed in project specifications

- C. Resubmission of rejected submittals shall be limited to one (1) in number. Costs for processing subsequent resubmittals in excess of the first resubmittal, resulting from the Contractor's disregard of Architect/Engineer's primary submittal rejection comments, shall be borne by the Contractor. Costs shall be based on Architect/Engineer's hourly rates as published in their current professional fee schedules and shall also include reimbursable costs for delivery, mailing, and photocopies at direct cost plus ten percent (10%).
- D. Submittals required of materials and equipment include following:
1. Materials list of items proposed to be provided under Division 26.
  2. Manufacturer's specifications and other data needed to prove compliance with specified requirements. Term "Compliance" is understood to mean that Contractor certifies that submitted equipment meets or exceeds Contract Document requirements. Items that do not clearly meet this definition should be identified and explained as required in following paragraph.
  3. Identify difference between specified item and proposed item. Explain with enough detail so that it can easily be determined that item complies with functional intent. List the disadvantages or advantages of proposed item versus specified item. Submit technical data sheets and/or pictures and diagrams to support and clarify. Organize in clear and concise format. Substitutions shall be approved in writing by Engineer. Engineer's decision shall be final.
  4. Allow minimum of 10 working days for review of each submittal and re-submittal.
  5. Items of equipment that are not accepted in writing as approved equal shall be replaced or revised to comply with Contract Documents at Contractor's expense.
  6. The manufacturers recommended installation procedures shall become basis for accepting or rejecting actual installation procedures used on Work.
  7. Shop drawings shall consist of detailed drawings with dimensions, schedules, weights, capacities, installation details and pertinent information needed to describe the material or equipment.
- E. Submittals required of materials and equipment under this Division include following listed items not supplied by Owner. These submittal requirements are intended to be complimentary to requirements that may be listed in individual sections. In event of conflict, more stringent requirement shall apply.
1. Conductors and Cables:
    - a. Submit product data for each specified product.
    - b. Submit tabular list of wire and wiring systems that will be increased in capacity or size to comply with Section 26 05 19 and/or similar requirements shown on Drawings. List shall include size shown on Drawings, proposed increase to comply with Section 26 0519, and proposed installed length.
  2. Raceways and Boxes:
    - a. Submit product data for surface raceways, wireways and fittings, floor boxes, hinged-cover enclosures, and cabinets.
    - b. Submit Shop Drawings including layout drawings showing components and wiring for nonstandard boxes, enclosures, and cabinets.
  3. Wiring Devices:
    - a. Submit product data for each specified product.
    - b. Submit operation and maintenance data for wiring devices, for inclusion in "Operating and Maintenance Manual" specified in this Section.
    - c. Submit dimension plan for locations of all non-standard devices including but not limited to floor boxes, ceiling boxes, cord reels and welding boxes.

4. Switchboards:
  - a. Submit product data for each product and component specified.
  - b. Submit Shop Drawings for each switchboard including dimensioned plans and elevations, component and device lists, and single-line diagram showing main and branch bus current ratings and short-time and short-circuit ratings of switchboard.
  - c. Submit schedule of features, characteristics, ratings, and factory settings of individual protective devices.
  - d. Submit manufacturer's schematic wiring diagram.
  - e. Submit point-to-point control wiring diagram, differentiating between manufacturer-installed and field-installed wiring.
  - f. Submit qualification data for field-testing organization certificates, signed by Contractor, certifying that organization complies with requirements specified in Quality Assurance below. Include list of completed projects with project names, addresses, names of Engineers and Owners, plus other information specified.
  - g. Submit maintenance data for materials and products, for inclusion in Operating and Maintenance Manual as specified in this Section.
5. Grounding:
  - a. Submit product data for grounding rods, connectors and connection materials, and grounding fittings.
6. Dry-Type Transformers:
  - a. Submit product data for each product specified, including dimensioned plans, sections, and elevations. Show minimum clearances and installed features and devices.
  - b. Submit wiring diagrams of products differentiating between manufacturer-installed and field-installed wiring.
  - c. Submit product certificates signed by manufacturers certifying that their products comply with specified requirements.
  - d. Submit operation and maintenance data for materials and products to include in "Operating and Maintenance Manual" specified in this Section.
7. Panelboards:
  - a. Submit product data for each type panelboard, accessory item, and component specified.
  - b. Submit Shop Drawings prepared by the manufacturers including dimensioned plans, sections, and elevations. Show tabulations of installed devices, major features, and voltage rating. Include enclosure type with details for types other than NEMA Type 1; bus configuration and current ratings; short-circuit current rating of panelboard; and features, characteristics, ratings, and factory settings of individual protective devices and auxiliary components.
  - c. Submit typewritten panelboard schedules to the Engineer for approval prior to installation.
  - d. Submit maintenance data for panelboard components, for inclusion in Operating and Maintenance Manual specified in this Section. Include instructions for testing circuit breakers.
8. Disconnect Switches:
  - a. Submit product data for disconnect switches and specified accessories.
9. Automatic Transfer Switches:
  - a. Submit Shop Drawings or product data for each transfer switch, including dimensioned plans, sections, and elevations showing minimum clearances; conductor entry provisions; gutter space; installed features and devices; and materials lists.

- b. Submit wiring diagrams, elementary or schematic, differentiating between manufacturer-installed and field-installed wiring.
  - c. Submit operation and maintenance data for each type of product, for inclusion in Operating and Maintenance Manual specified in this section. Include features and operating sequences, both automatic and manual. List factory settings of relays and provide relay setting and calibration instructions.
  - d. Submit manufacturer's certificate of compliance to referenced standards and tested short-circuit closing and withstand ratings applicable to protective devices and current ratings.
10. Engine-Generator Set:
- a. Submit exhaust emissions. Submit prototype test data.
  - b. Submit wiring diagrams for system, showing power and control connections and distinguishing between factory-installed and field-installed wiring.
  - c. Submit product data for products specified in this Section. Include data on features, components, ratings, and performance. Include a dimensioned outline plan and elevation drawings of the engine generator set, the weatherproof enclosure, sub-base fuel tank and other system components.
  - d. Submit maintenance data for system and components for inclusion in Operating and Maintenance Manual specified in this Section.
  - e. Submit detailed operating instructions, covering operation under both normal and emergency conditions and sound test reports.
  - f. Submit certification of torsional vibration compatibility: Conform to NFPA 110.
  - g. Submit factory test reports for units to be shipped for this Project showing evidence of compliance with specified requirements.
11. Motor Controllers:
- a. Submit product data for specified products. Include dimensions, ratings, and data on features and components.
  - b. Submit maintenance data for products for inclusion in Operating and Maintenance Manual specified in this Section.
12. Interior Lighting:
- a. Submit product data describing fixtures, lamps, ballasts, and emergency lighting units. Arrange product data for fixtures in order of fixture designation. Include data on features and accessories.
  - b. Submit outline drawings indicating dimensions and principal features of fixtures, including color.
  - c. Submit electrical ratings and photometric data including certified results of laboratory tests for fixtures and lamps.
  - d. Submit battery and charger data for emergency lighting units.
  - e. Submit Shop Drawings detailing nonstandard fixtures and indicating dimensions, weights, and methods of field assembly, components, features, and accessories.
  - f. Submit wiring diagrams detailing wiring for control system showing both factory-installed and field-installed wiring for each specific system which differentiates between factory-installed and field-installed wiring.
  - g. Submit maintenance data for fixtures to include in operation and maintenance manual specified in this Section.
  - h. Submit lamp data for each fixture.
13. Fire Alarm System:
- a. Submit product data for each type of system component specified including dimensioned plans and elevations showing installed features and devices. Include list of materials and nationally recognized testing laboratory-listing data. Submit to Engineer after being reviewed and approved by local authority having jurisdiction.

- b. Submit wiring diagrams from manufacturer differentiating clearly between factory- and field-installed wiring. Include diagrams for equipment and for system with terminals and interconnections identified. Make diagrams specific to this Project and distinguish between field and factory wiring.
  - c. Submit device address list.
  - d. Submit system operation description covering this specific Project, including method of operation and supervision of each type of circuit and sequence of operations for manually and automatically initiated system inputs and outputs. Manufacturer's standard descriptions for generic systems are unacceptable.
  - e. Submit operating instructions for mounting at fire alarm control panel.
  - f. Submit battery hours of operation calculations for loss of normal power operation.
  - g. Submit maintenance data for fire alarm systems to include in operation and maintenance manual specified in this Section. Include data for each type of product, including features and operating sequences, both automatic and manual. Include recommendations for spare parts to be stocked at site. Provide names, addresses, and telephone numbers of service organizations that carry stock of repair parts for system to be furnished.
  - h. Submit design drawings approved by local authority having jurisdiction.
14. Provide a dimension layout of electrical rooms(s) and elevator equipment room(s) if applicable.

#### 1.7 SUBSTITUTIONS

- A. The Contract Documents list manufacturers' names and catalog numbers followed by phrase "or equal" are to establish a standard of quality and utility for the specified items and to provide a dimensional reference to the scaled drawings.
- B. Submittals for "equal" items shall include the following data, which is not necessarily required for specified items, which list the manufacturer and catalog number:
  1. Performance characteristics.
  2. Materials.
  3. Finish.
  4. Certification of conformance with specified codes and standards.
  5. Manufacturer's specifications and other data needed to prove compliance with specified requirements. Term "compliance" is understood to mean that the submitted equipment will meet or exceed the Contract Document requirements. Items that do not clearly meet this definition shall be identified and explained as required in following Paragraph.
  6. Identify all differences between the specified item and proposed item. Explain all differences with sufficient detail to permit the Engineer to easily determine that the substituted item complies with the functional intent. List disadvantages and advantages of proposed item versus specified item. Submit technical data sheets and/or pictures and diagrams to support and clarify. Organize in clear and concise format. Engineer shall approve substitutions in writing. Engineer's decision shall be final.
- C. Submittals of "equal" components or systems may be rejected if:
  1. Material or equipment would necessitate alteration of mechanical, electrical, architectural, or structural design.
  2. Dimensions vary from specified material or equipment so that accessibility or clearances are impaired or Work of other trades is adversely affected.



- D. Proposed substitutions for materials or equipment must be submitted seven (7) days prior to final bid date for consideration as approved equals. Otherwise, substitutions will not be permitted. Only the prime bidders shall be permitted make proposals for substitutions.
- E. No substitution shall be made unless authorized in writing by the Engineer. Should substitution be accepted, and should substitute material prove defective or otherwise unsatisfactory for service intended, and within guarantee period, replace this material or equipment with material or equipment specified, to satisfaction of Engineer and at no cost to Owner.

**1.8 ORDINANCES, PERMITS, METERS, UTILITIES AND ROYALTIES**

- A. Purchase all necessary permits and licenses necessary for completion of the Work. Pay all lawful fees required and necessary pursuant in obtaining said permits and licenses. Required certificates of approvals and inspections by local governing and regulating authorities.
- B. Pay all fees required for connection of utility power and telephone services required for the Work.
- C. Pay royalty payments or fees required for use of patented equipment or systems. Defend lawsuits or claims for infringement of patent rights and hold Owner and/or Engineer harmless from loss as result of said suits or claims.

**1.9 COMPATIBILITY OF EQUIPMENT**

- A. Assume full responsibility for satisfactory operation of component parts of electrical systems. Assure compatibility of equipment and performance of integrated systems in accordance with requirements of the Construction Documents. Notify the Engineer before submitting a bid should Specifications or Drawings make acceptance of responsibility impossible, prohibitive, or restrictive. The bid shall be accompanied by a written statement listing any objections or exceptions to the applicable specification section and/or drawing.

**1.10 UTILITIES AND TEMPORARY POWER**

- A. Verify location and capacity of all existing utility services before starting Work. The locations and sizes of electrical lines are shown in accordance with data secured from Owner's survey. The data shown is offered as estimating guide without guarantee of accuracy.
- B. Pay all utility charges for temporary power. Provide temporary lighting and power required. Install in accordance with OSHA requirements and as described in General Requirements Division 01.

**1.10 FLASHINGS, SLEEVES, AND INSERTS**

- A. Furnish and install flashings where conduits pass through outside walls. Flashings shall be properly formed to fit around conduit and shall be caulked, with 790 Silicone Building Sealant by Dow Corning Corporation, so as to make watertight seal between conduit and building.
- B. Unless otherwise specified, install sleeves for each conduit where it may pass through interior walls or floors. Galvanized 22-gage sheet iron sleeves shall be used. Finish flush with each finished wall surface. In pipe chases, the sleeve shall extend 1-1/2 inches above floor slab and shall be watertight.

- C. Raceways that pass through concrete beams or walls and masonry exterior walls shall be provided with galvanized wrought iron pipe sleeves, unless shown otherwise on drawings. Inside diameter of these sleeves shall be at least 1/2 inch greater than outside diameters of service pipes. After pipes are installed in these sleeves, fill annular space between pipes and sleeves with 790 Silicone Building Sealant by Dow Corning Corporation. Completed installation shall be watertight.
- D. Roof penetrations shall be provided with counter flashings arranged to provide weatherproof installation.
- E. Penetrations through walls, floors and ceilings shall be done in manner to maintain integrity of fire rating of respective wall, floor, or ceiling.
- F. Reference Division 7 for additional sealant requirements. Where conflicts occur with the specified requirements, the more stringent shall apply.

#### 1.11 CUTTING AND PATCHING

- A. Perform cutting and patching in strict accordance with provisions of these Specifications and following:
  - 1. Coordinate Work to minimize cutting and patching.
  - 2. Use adequate number of skilled workers who are thoroughly trained and experienced in necessary crafts and who are completely familiar with specified requirements and methods needed for proper performance of Work.
- B. Request for Engineer's consent:
  - 1. Prior to cutting which affects structural safety, submit a written request to Engineer for permission to proceed with cutting.
  - 2. When conditions of Work or schedule require a change of materials or methods for cutting and patching, notify Engineer and secure written permission to proceed with the work.
- C. Perform cutting and demolition using methods that will prevent damage to other portions of Work.
- D. Perform fitting and adjusting to provide a finished installation complying with specified tolerances and finishes.

#### 1.12 SURFACE CONDITIONS

- A. Examine areas and conditions under which Work of this Division will be performed. Work required to correct conditions detrimental to timely and proper completion of Work shall be included as part of Work of this Division. Do not proceed until unsatisfactory conditions are corrected.

#### 1.13 CONSTRUCTION REQUIREMENTS

- A. Drawings show arrangements of Work. Rearrangement of spaces and equipment will be considered when Project conditions make this necessary and/or materials or equipment can be installed to better advantage. Prior to proceeding with Work, coordinate with various trades to prepare and submit five (5) copies of Drawings of proposed arrangement for Engineer's review. Allow minimum of 10 working days for review.

- B. Installation or rearrangement of equipment and space for Contractor's convenience or to accommodate material or equipment substitutions will be considered. Assume responsibility for rearrangement of equipment and space and have Engineer review change before proceeding with Work. Request for changes shall be accompanied by Shop Drawings of affected equipment and space. Identify proposed monetary credits or other benefits. Allow minimum of 10 working days for review.
- C. Properly locate and size all required pipe sleeves and slots, holes, or openings in structure.

#### 1.14 PREPARATION AND COORDINATION

- A. Coordinate the work in strict accordance with the Contract Documents as follows:
  - 1. Where lighting fixtures and other electrical items are shown in conflict with locations of structural members and mechanical or other equipment, provide required supports and wiring to clear encroachment.
  - 2. Install power and control wiring for installation of equipment furnished under Divisions 21, 22 and 23. Furnish disconnect switches and other equipment as required for proper operation of equipment unless equipment is specified to be factory mounted.
- C. Information on the Drawings and in these Specifications is as accurate as could be secured, but absolute accuracy is not guaranteed. The drawings are diagrammatic, and the exact locations, distances, levels, and other conditions shall be governed by actual construction. The drawings and specifications shall be for guidance.
- D. Where receptacle locations are not dimensioned on either the Architectural or Engineering Drawings, the J-box may be located on the nearest stud. When receptacles are dimensioned on the Drawings, Provide a cross brace and mount the receptacle as dimensioned.
- E. Field-verify measurements. No extra compensation will be allowed because of differences between Work shown on Drawings and actual site measurements.
- F. Branch circuit wiring and arrangement of home runs have been designed for maximum economy consistent with adequate sizing and other considerations. Increase size of wiring and wiring systems to accommodate more stringent requirements listed in these Specifications or on Drawings. Install wiring with circuits arranged as shown on Drawings. Deviations shall be approved in advance by Engineer.

#### 1.15 PROJECT RECORD DOCUMENTS

- A. Provide Project record documents associated with Work in accordance with provisions of these Specifications. Refer to Division 1 for additional requirements.
- B. Throughout progress of the Work, maintain accurate record of all changes in Contract Documents (Drawings and Specifications). Changes shall include Addendums issued during bidding and location of electrical service lines, receptacles, and outside utilities.
- C. Delegate responsibility for maintenance of record documents to one person on Contractor's staff.
- D. Accuracy of Records
  - 1. Thoroughly coordinate changes within record documents, making adequate and proper entries on each page of Specifications and each sheet of Drawings and other documents

- where required to show change properly. Match symbology and format of base documents.
2. Accuracy of records shall be such that future searches for items shown in Contract Documents may rely reasonably on information obtained from approved Project record documents.
- D. Maintain a job set of record documents protected from deterioration and from loss and damage until completion of Work. Transfer all recorded data to final Project record documents.
- F. Making Entries on Drawings
1. Using erasable colored pencil (not ink or indelible pencil), clearly describe change by graphic line and note as required.
  2. Date entries.
  3. Call attention to entry by "cloud" drawn around area or areas affected.
  4. In event of overlapping changes, use different colors for overlapping changes.
  5. Make entries within 24 hours after receipt of information that changes have occurred.
  6. Maintain base drawing format and use the same symbols.
  7. Convert field mark-ups to finished CADD record drawings when required in this Section.
- G. Conversion of Schematic Layouts
1. In some cases on Drawings, arrangements of conduits, circuits, and similar items, are shown schematically and are not intended to portray precise physical layout. Determine final physical arrangement, subject to Engineer's approval. The design of future modifications of facility may require accurate information as to final physical layout of items that are shown only schematically on Drawings. Show by dimension accurate to within one inch, centerline of each run of sleeves and conduit below grade, in walls, or in concrete slab, etc. Surface mounted device indicates exact location:
    - a. Clearly identify item by accurate note (e.g., "Rigid Conduit").
    - b. Show, by symbol or note, vertical location of item "under slab," "in ceiling plenum," "exposed," etc.
    - c. Make identification sufficiently descriptive that it may be related reliably to Specifications.
- H. Final Project Record Documents
1. The purpose of the final Project Record Documents is to provide factual information regarding all aspects of the Work, both concealed and visible, to enable future modification of the Work to proceed without lengthy and expensive site measurement, investigation, and examination.
  2. Provide CADD electronic files in dwg Format using AutoCAD Release 2002 or later software. Upon written request, completion of a release form, and payment of the Engineer's standard fee of \$200 plus applicable sales tax for a set-up charge and \$50 per drawing plus applicable sales tax for copies of such files, Engineer will provide AutoCAD Release 2002 electronic files of base Contract Drawings in dwg format on compact discs. Engineer will also provide a list of drawing layers and names that shall be maintained.
  3. Provide completed record drawings on CD and one mylar film reproducible of each drawing.
  4. Refer to Division 01 for additional requirements.

1.16 OPERATION AND MAINTENANCE DATA

- A. Submit two copies of preliminary draft of proposed manual or manuals to Engineer for review and comments. Allow minimum of 10 working days for review.
- B. Submit approved manual to Engineer prior to indoctrination of operation and maintenance personnel.
- C. Where instruction manuals are required for submittal, they shall be prepared in accordance with the following:

Format:	
Size:	8-1/2-inch by 11-inch
Paper:	White bond, at least 20 pound weight
Text:	Neatly written or printed
Drawings:	11 inches in height preferable; bind in with text; foldout acceptable; larger drawings acceptable but fold to fit within Manual and provide drawing pocket inside rear cover or bind in with text.
Flysheets:	Separate each section of Manual with neatly prepared flysheets briefly describing contents of ensuing section; flysheets may be in color.
Binding:	Use heavy-duty plastic or fiberboard covers with binding mechanism concealed inside manual; 3-ring binders will be acceptable; binding is subject to Engineer's approval.
Measurements:	Provide measurements in U.S. standard units (e.g., feet, inches, and pounds). Where items may be expected to be measured within 10 years in accordance with metric formulae, provide additional measurements in "International System of Units" (SI).

- D. Provide front and back covers for each manual, using durable material approved by Engineer, and clearly identified on or through cover with at least following information:

<p><b><i>O&amp;M Manual Requirements</i></b> <i>MEP &amp; Fire Suppression</i></p> <ul style="list-style-type: none"><li>• Title Page<ul style="list-style-type: none"><li>○ Job Name</li><li>○ Site Address</li><li>○ Include Contact information of prime contractor.</li></ul></li><li>• Table of contents</li><li>• Warranty Information.<ul style="list-style-type: none"><li>○ Include all contractor warranties<ul style="list-style-type: none"><li>▪ Signed and dated documents</li></ul></li></ul></li><li>• Permits-Inspections</li><li>• Subcontractor list<ul style="list-style-type: none"><li>○ Include all subcontractors.<ul style="list-style-type: none"><li>▪ Company name, Contact info.</li><li>▪ Trade Responsibility.</li></ul></li></ul></li><li>• Vendor list<ul style="list-style-type: none"><li>○ Include name and addresses of vendors<ul style="list-style-type: none"><li>▪ Warranty information</li><li>▪ Replaceable parts</li></ul></li></ul></li><li>• Approved submittals<ul style="list-style-type: none"><li>○ Include all approved product submittals</li></ul></li><li>• Reports/Certificates/Redlines<ul style="list-style-type: none"><li>○ Engineers Observation Reports</li><li>○ Electrical tests.</li><li>○ Grounding test Report</li><li>○ Generator testing</li><li>○ Overcurrent Protection Study</li><li>○ Sequence of operations report</li><li>○ Surge Protection Commissioning Report</li><li>○ Contractor Start-up Report</li><li>○ Manufacturer Start-up Report</li><li>○ Owners Training Report. (All Trades)</li></ul></li><li>• O&amp;M Manuals</li><li>• Equipment Information.<ul style="list-style-type: none"><li>○ Include Model, Serial and location.</li></ul></li><li>• Signed Approval<ul style="list-style-type: none"><li>○ Page for approval signature of the engineer and approval date.</li></ul></li></ul>
--

**OPERATING AND MAINTENANCE INSTRUCTION**

Name and Address of Work

Name of Contractor

General subject of this manual

Space for approval signature of Engineer and approval date[s]

- E. Contents: Include at least following:
1. Neatly typewritten index near front of Manual, giving immediate information as to location within manual of emergency information regarding installation.
  2. Complete instructions regarding operation and maintenance of equipment involved including lubrication, disassembly, and reassembly.
  3. Complete nomenclature of parts of equipment.
  4. Complete nomenclature and part number of replaceable parts, name and address of nearest vendor and other data pertinent to procurement procedures.

5. Copy of guarantees and warranties issued.
6. Manufacturer's bulletins, cuts, and descriptive data, where pertinent, clearly indicating precise items included in this installation and deleting, or otherwise clearly indicating, manufacturers' data with which this installation is not concerned.
7. Other data as required in pertinent Sections of these Specifications.

**1.17 EQUIPMENT FOUNDATIONS**

- A. Provide equipment foundations in accordance with provisions of these Specifications.
- C. Provide concrete bases for main switchboard, distribution panelboards, floor-mounted transformers and other equipment that is to be pad- or floor-mounted. Bases shall be 4 inches high above finished floors or grades (unless otherwise noted) and shall protrude 2 inches beyond sides of equipment and shall have exposed chamfered edges. Construct bases from ready-mixed hard rock concrete, ASTM C94, reinforced with #3 Rebars, ASTM A615, Grade 40. Rebars shall be located at 18 inches on center each way.
- D. Field-verify exact location of outdoor pad mounted equipment with Engineer. Supply necessary fill and grade site to provide natural drainage away from equipment.
- E. Provide structural concrete foundations for generator, pad mounted transformers and lighting pole bases.

**1.18 TESTING AND INSPECTION**

- A. Provide personnel and equipment, make required tests, and secure required approvals from Engineer and Governmental Agencies having jurisdiction
- B. Make written notice to Engineer adequately in advance of each of following stages of construction:
  1. When rough in is complete, but not covered
  2. At completion of Work of this Division
  3. In underground condition prior to placing backfill, concrete floor slab, and when associated electrical Work is in place
- C. When material or workmanship is found to not comply with specified requirements, remove items from job site and replace them with items complying with specified requirements at no additional cost to Owner. This shall be performed within 3 days after receipt of written notice of noncompliance.
- D. In Engineer's presence, test parts of electrical system and prove that items provided under this Division function electrically in required manner.

**1.19 SITE VISITS BY FACTORY PERSONNEL**

- A. Pay for travel expenses, living expenses, and miscellaneous expenses associated with site visits of factory personnel to perform on site testing, inspections, and reviews.

**1.20 WARRANTY**

- A. Warrant equipment and workmanship for period of one year after date of substantial completion and replace or repair faulty equipment or installation at no cost to Owner for service during this period, in accordance with requirements of Division 1.
- B. Warranty shall not void specific warranties issued by manufacturers for greater periods of time or void rights guaranteed to Owner by law.
- C. Warranties shall be in writing in form satisfactory to Owner, and shall be delivered to Owner before final payment is made.
- D. All manufacturers shall provide the manufacturers warranties starting at time of start-up and not at time of delivery.

**1.21 PROJECT COMPLETION**

- A. Upon completion of Work of this Division, thoroughly clean exposed portions of electrical installation, removing traces of soil, labels, grease, oil, and other foreign material, and using only type cleaner recommended by manufacturer of item being cleaned.
- B. Thoroughly indoctrinate Owner's operation and maintenance personnel in contents of operations and maintenance manual required to be submitted as part of this Division of these Specifications.

**1.22 TRAINING**

- A. Contractors are responsible to provide owner with an adequate amount of training to be able to operate any system installed.
  - 1. This includes training for any Lighting Controls, Generator, Digital Controls, Security systems,
  - 2. Provide a sign in sheet that is to be added to the O&M manual
    - 1. Owners & all building maintenance personal are required to have training.

END OF SECTION



THIS PAGE INTENTIONALLY LEFT BLANK

**SECTION 26 05 01- ELECTRICAL DEMOLITION**

**PART 1 - GENERAL**

**1.1 RELATED DOCUMENTS**

- A. The Drawings and General Provisions of the Contract, including General and Supplementary Conditions and Division 01 Specification Sections, apply to the Work in this Section.

**1.2 SUMMARY**

- A. Provided all equipment, materials, labor supervision, and services necessary for or incidental to the demolition of electrical equipment and materials as indicated on the drawings, and as specified.
- B. Work included:
  - 1. Removal of panels, switchboards, light fixtures, receptacles, conduit and wire and other electrical equipment and materials where indicated.
  - 2. Arrange for the disposal of lamps and ballasts in accordance with TSCA.

**1.3 STANDARDS**

- A. All work shall comply with the Toxic Substances Control Act (TSCA) 1976.

**1.4 SUBMITTALS AND SHOP DRAWINGS**

- A. Submit qualifications of the disposal company.

**1.5 QUALITY ASSURANCE**

- A. Use adequate numbers of skilled workers who are thoroughly trained and experienced in the necessary crafts and who are completely familiar with the specified requirements and the methods needed for proper performance of the work of this Section.
- B. Without additional cost to the Owner, provide such other labor and materials as are required to complete the work of this Section in accordance with the requirements of governmental agencies having jurisdiction, regardless of whether such materials and associated labor are called for elsewhere in these Contract Documents.

**PART 2 - PRODUCTS (NOT USED)**

**PART 3 – EXECUTION**

**3.1 DISCONNECTION OF THE SOURCES OF POWER**

- A. Prior to the demolition of work by any trade, provide a qualified electrician to disconnect all sources of power serving equipment, light fixtures and outlets within the area of demolition. Verify by testing that power has been disconnected. The electrician shall remain on the site during demolition, to disconnect and test electrical work that becomes accessible during the course of demolition.

**3.2 SALVAGE AND DISPOSAL**

- A. Tour the project site with the Owner's representative to identify and mark those items, scheduled for demolition, which the Owner wishes to retain. Deliver those items so marked, to the Owner's storage, within the project site, as directed.
- B. All remaining demolition items shall become the Contractor's property and shall be removed from the site. Hazardous materials shall be disposed of in accordance with federal regulations.
- C. Refer to Section 26 5700 for additional instructions concerning the disposal of lamps and ballasts.

**3.3 CONDUIT, WIRE AND PANELBOARDS**

- A. Where equipment, wiring devices and/or light fixtures are scheduled for demolition, remove the associated wire and raceway back to the circuit breaker serving the equipment, unless specifically noted otherwise.
- B. Where panelboards are scheduled for demolition and some of the branch circuits are to remain, re-connect the existing circuits to replacement panelboards as noted on the drawings.
- C. Where ceilings or walls are scheduled for demolition on the Architectural drawings, disconnect and remove all wiring devices, light fixtures, and other outlets associated with those walls and ceilings.

**3.4 FIRE ALARM SYSTEM**

- A. Remove all components of the existing fire alarm system, within the area of demolition, including conduit, wire, initiating devices, and annunciating devices.

**END OF SECTION**

**SECTION 26 05 02 - ELECTRICAL WORK IN EXISTING FACILITIES**

**PART 1 – GENERAL**

**1.1 RELATED DOCUMENTS**

- A. The Drawings and General Provisions of the Contract, including General and Supplementary Conditions and Division 01 Specification Sections, apply to the Work in this Section.

**1.2 SUMMARY**

- A. Provide labor, materials, equipment, transportation, tools and services, and perform operations required for, and reasonably incidental to the providing or modification of electrical work and systems in existing facilities.

**1.3 SHOP DRAWINGS**

- A. Show the joining of new work with existing, illustrating the actual existing conditions in accordance with Division 1.

**1.4 QUALITY ASSURANCE**

- A. Use adequate numbers of skilled workmen who are thoroughly trained and experienced in the necessary crafts and who are completely familiar with the specified requirements and the methods needed for proper performance of the work of this Section.
- B. Without additional cost to the Owner, provide such other labor and materials as are required to complete the work of this Section in accordance with the requirements of governmental agencies having jurisdiction, regardless of whether such materials and associated labor are called for elsewhere in these Contract Documents.

**PART 2 - PRODUCTS**

**2.1 WIRING METHODS AND MATERIALS**

- A. Where new conduits, wires, cables, outlets, light fixtures wiring devices, fire alarm devices, etc. are installed, they shall be of the type and quality specified, regardless of the types and quality of existing materials that are to remain.
- B. Where existing light fixtures are shown to be relocated and such relocation can be made without disconnecting and extending the existing wiring, the light fixture and wiring may remain, if permitted by local codes, for the occupancy under construction.
- C. Where existing light fixtures are shown to be removed, they must not be used elsewhere as they are not suitable for meeting the energy code.

**PART 3 – EXECUTION**

**3.1 SITE INSPECTION**

- A. The Contract Documents do not propose to show all existing systems material or equipment. Obtain information related to existing facilities from existing documents, measurements, notations, photographs, surveys and other observations at the site.

- B. Visit the project site and verify the existing materials, conditions, wiring methods, penetrations through fire rated walls, supporting devices and panelboards. Inspect ceiling spaces, panelboard interiors, connections to light fixtures, etc. Note any existing conditions which require work to bring the project into code compliance for the occupancy under construction.
- C. Modify, repair and replace materials relating to any existing conditions whether shown on the drawings, noted during the site visit or discovered during the course of construction, which require work to bring the project into code compliance for the occupancy under construction.
- D. Where existing light fixtures are shown to remain, - clean, re-lamp, repair damaged parts and replace ballast if defective so as to bring the fixture to good operating condition.
- E. Where new inaccessible ceilings are shown to be installed, survey the existing conditions and relocate any j-boxes, pull boxes and any other items of electrical equipment requiring access. Where such relocations are difficult, coordinate with the architect to provide an access panel.

### 3.2 SCHEDULE OF WORK

- A. Since the building will continue in use throughout the construction period, carry out the work under this Division in such a manner as to minimize disturbance to the occupants.
- B. The schedule contemplates working in designated areas in the existing building while other adjacent areas are still being occupied. Carry out work in this Division in such a manner as to minimize disturbance to those occupied areas.
- C. Should the work in the designated areas affect any services to the areas to remain in use, new permanent or temporary services or a combination of both shall be installed as required to enable those occupied areas to function properly.
- D. Perform no work in the existing building which would interfere with its use during normal hours of occupancy, unless special permission is granted by the Owner. Included shall be operations which would cause objectionable noise or service interruptions.
- E. Any work involving a service suspension shall be scheduled in advance with the Owner.
- F. Should it be necessary to perform certain operations on an "overtime" basis in order not to interrupt the normal usage of the building, include the costs of such overtime without change in the Contract amount.

### 3.3 TEMPORARY WORKING ACCESS

- A. Remove existing wire, conduit, equipment, fixtures, and other items as required to provide access for work in existing facilities.
- B. Reinstall and refinish items removed, or otherwise damaged, to match existing adjacent conditions upon completion of the work.

### 3.4 DISRUPTION OF EXISTING FUNCTIONS

- A. Access: Access to and use of the existing facilities and site will be restricted, and shall be under the direction and control of the Owner.
- B. Outages: Schedule power outages to avoid interference with the Owner's or other tenant's activities. Obtain approval prior to the requested outage as specified in Division 1. Provide a schedule showing sequence and duration of all activities during the requested outage.

- C. Disruptions: Maintain existing electrical, communications, alarm, and other existing systems, and maintain existing functions in service except for scheduled disruptions as specified in Division 1. Where existing functions to remain in use are disrupted, they shall be fully restored after disruption, in full compliance with this Division of the Specifications.
- D. Duration: Complete as large a portion of the work as possible before initiating disruption and perform only that work necessary so as to minimize duration of disruption. Maintain adequate personnel, supplies, materials, equipment, tools, and other resources at job site to avoid unnecessary delay in resumption of normal service.
- E. Schedule: Provide a complete schedule to the Owner for review and approval indicating the type and duration of any required disruption involved in the execution of the work.

### 3.5 SALVAGE, DEMOLITION AND RELOCATION

- A. General
  - 1. Modify, remove, or relocate materials, equipment and devices as indicated or required by the installation of new facilities.
  - 2. Working jointly with the Owner's Representative, establish and mark salvage and demolition items before commencing work; report items scheduled for relocation, reinstallation or reuse, which are found to be in damaged condition; await further instructions from the Owner before commencing with work.
  - 3. Demolition material shall be removed from the site and disposed of by the Contractor. Salvaged equipment and devices shall be the property of the Owner unless noted otherwise. Store or dispose of as directed by Owner.
- B. Relocations
  - 1. Make minor relocations necessitated by the conditions at the site or as directed by the Owner's Representative, without additional cost to the Owner.
  - 2. Repair and restore to good functional condition, equipment, materials and items scheduled for relocation, which are damaged during dismantling or reassembly operations.
  - 3. New materials and items of similar design and quality may be substituted for materials and items indicated to be relocated upon approval of Shop Drawings, product data, and samples.
  - 4. Remove carefully, in reverse order to original assembly or placement, items which are to be relocated.
  - 5. Protect items until relocation is complete.
  - 6. Clean and repair items to be relocated, and provide new materials, fittings, and appurtenances required to complete the relocations and to restore to good operating order.
  - 7. Perform the relocation work in full compliance with this Division of the Specifications, utilizing skilled workers.
- C. Relocating Devices: Remove and reinstall in locations designated by the Owner's Representative wiring devices, fixtures, equipment, other devices and associated wire and conduit required for the operation of the various systems that are installed in existing-to-be-removed construction.

**END OF SECTION**

THIS PAGE INTENTIONALLY LEFT BLANK

**SECTION 26 05 03 - FIRESTOPPING**

**PART 1 – GENERAL**

**1.1 RELATED DOCUMENTS**

- A. The Drawings and General Provisions of the Contract, including General and Supplementary Conditions and Division 01 Specification Sections, apply to the Work in this Section.

**1.2 SUMMARY**

- A. Only tested firestop systems shall be used in specific locations as follows:
  - 1. Penetrations for the passage of conduit and other electrical equipment through fire-rated vertical barriers (walls and partitions), horizontal barriers (floor/ceiling assemblies), and vertical service shaft walls and partitions.
  - 2. Completion of firestop installations to maintain the rating integrity of the barrier penetrated.
  - 3. **SUBMITTALS: Provide submittals as required in section 26 05 10, "Submittal Process."**

**1.3 DEFINITIONS**

- A. Firestopping: Material or combination of materials used to retain integrity of fire-rated construction by maintaining an effective barrier against the spread of flame, smoke, water and hot gases through penetrations in fire rated wall and floor assemblies.

**1.4 REFERENCES**

- A. Test Requirements: ASTM E-814, "Standard Method of Fire Tests of Through Penetration Fire Stops" (July 1997).
- B. Underwriters Laboratories (UL) of Northbrook, IL runs ASTM E-814 under their designation of UL 1479 and publishes the results in their "FIRE RESISTANCE DIRECTORY" that is updated annually.
  - 1. UL Fire Resistance Directory:
    - a. Through-Penetration Firestop Devices (XHCR)
    - b. Fire Resistance Ratings (BXUV)
    - c. Through-Penetration Firestop Systems (XHEZ)
    - d. Fill, Voids, or Cavity Material (XHHW)
    - e. Forming Materials (XHKU)
- C. Inspection Requirements: ASTM E 2174-01 "Standard Practice for On-Site Inspection of Installed Fire Stops".
- D. International Firestop Council Guidelines for Evaluating Firestop Systems Engineering Judgments.
- E. ASTM E-84, Standard Test Method for Surface Burning Characteristics of Building Materials.
- F. All major building codes: ICBO, SBCCI, BOCA, and IBC. (Note to specifier: Retain or delete building codes listed above as applicable).
- G. NFPA 101 - Life Safety Code



- H. NFPA 70 – National Electric Code.

#### 1.5 QUALITY ASSURANCE

- A. A manufacturer's direct representative (not distributor or agent) to be on-site during initial installation of firestop systems to train appropriate contractor personnel in proper selection and installation procedures. This will be done per manufacturer's written recommendations published in their literature and drawing details.
- B. Firestop System installation must meet requirements of ASTM E-814 or UL 1479 tested assemblies that provide a fire rating equal to that of construction being penetrated.
- C. Proposed firestop materials and methods shall conform to applicable governing codes having local jurisdiction.
- D. Firestop Systems do not reestablish the structural integrity of load bearing partitions/assemblies, or support live loads and traffic. Installer shall consult the structural engineer prior to penetrating any load bearing assembly.
- E. For those firestop applications that exist for which no UL tested system is available through a manufacturer, a manufacturer's engineering judgment derived from similar UL system designs or other tests will be submitted to local authorities having jurisdiction for their review and approval prior to installation. Engineer judgment drawings must follow requirements set forth by the International Firestop Council (September 7, 1994 as may be amended from time to time).

#### 1.6 SUBMITTALS

- A. Submit Product Data: Manufacturer's specifications and technical data for each material including the composition and limitations, documentation of UL firestop systems to be used and manufacturer's installation instructions to comply with Section 1300.
- B. Manufacturer's engineering judgment identification number and drawing details when no UL system is available for an application. Engineer judgment must include both project name and contractor's name that will install firestop system as described in drawing.
- C. Submit material safety data sheets provided with product delivered to job-site.

#### 1.7 INSTALLER QUALIFICATIONS

- A. Engage an experienced Installer who is certified, licensed, or otherwise qualified by the firestopping manufacturer as having the necessary experience, staff, and training to install manufacturer's products per specified requirements. A manufacturer's willingness to sell its firestopping products to the Contractor or to an Installer engaged by the Contractor does not in itself confer qualification on the buyer.

#### 1.8 DELIVERY, STORAGE, AND HANDLING

- A. Deliver materials undamaged in manufacturer's clearly labeled, unopened containers, identified with brand, type, and UL label where applicable.
- B. Coordinate delivery of materials with scheduled installation date to allow minimum storage time at job-site.

- C. Store materials under cover and protect from weather and damage in compliance with manufacturer's requirements.
- D. Comply with recommended procedures, precautions or remedies described in material safety data sheets as applicable.
- E. Do not use damaged or expired materials.

**1.9 PROJECT CONDITIONS**

- A. Do not use materials that contain flammable solvents.
- B. Scheduling
  - 1. Schedule installation of CAST IN PLACE firestop devices after completion of floor formwork, metal form deck, or composite deck but before placement of concrete.
  - 2. Schedule installation of other firestopping materials after completion of penetrating item installation but prior to covering or concealing of openings.
- C. Verify existing conditions and substrates before starting work. Correct unsatisfactory conditions before proceeding.
- D. Weather conditions: Do not proceed with installation of firestop materials when temperatures exceed the manufacturer's recommended limitations for installation printed on product label and product data sheet.
- E. During installation, provide masking and drop cloths to prevent firestopping materials from contaminating any adjacent surfaces.

**PART 2 – PRODUCTS**

**2.1 FIRESTOPPING, GENERAL**

- A. Provide firestopping composed of components that are compatible with each other, the substrates forming openings, and the items, if any, penetrating the firestopping under conditions of service and application, as demonstrated by the firestopping manufacturer based on testing and field experience.
- B. Provide components for each firestopping system that are needed to install fill material. Use only components specified by the firestopping manufacturer and approved by the qualified testing agency for the designated fire-resistance-rated systems.
- C. Firestopping materials are either “cast-in-place” (integral with concrete placement) or “post installed”. Provide cast-in-place Firestop devices prior to concrete placement.

**2.2 ACCEPTABLE MANUFACTURERS**

- A. Subject to compliance with through penetration firestop systems (XHEZ) listed in Volume II of the UL Fire Resistance Directory, provide products of the following manufacturers as identified below:
  - 1. Hilti, Inc., Tulsa, Oklahoma (800) 879-8000
  - 2. Tremco Sealants & Coatings, Beechwood, Ohio (216) 292-5000
  - 3. 3M Fire Protection Products, St. Paul, Minnesota (612) 736-0203

4. Johns-Manville Firetemp
5. Other manufacturers listed in the U.L. Fire Resistance Directory – Volume 2

**2.3 MATERIALS**

- A. Use only firestop products that have been UL 1479, ASTM E-814 tested for specific fire-rated construction conditions conforming to construction assembly type, penetrating item type, annular space requirements, and fire-rating involved for each separate instance.
- B. Cast-in place firestop devices are installed prior to concrete placement for use with non-combustible and combustible plastic conduit penetrating concrete floors, the following products are acceptable:
1. Hilti CP 680 Cast-In Place Firestop Device
  2. Hilti CP 681 Tub Box Kit
  3. Equivalent products listed in the U.L. Fire Resistance Directory – Volume 2
- C. Sealants or caulking materials for use with non-combustible items including steel pipe, copper pipe, rigid steel conduit and electrical metallic tubing (EMT), the following products are acceptable:
1. Hilti FS-ONE Intumescent Firestop Sealant
  2. Hilti CP 604 Self-leveling Firestop Sealant
  3. Hilti CP 620 Fire Foam
  4. 3M Fire Stop Sealant 2000
  5. 3M Fire Barrier CP25 WB
  6. Tremco Tremstop Fyre-Sil Sealant
  7. Equivalent products listed in the U.L. Fire Resistance Directory – Volume 2
- D. Sealants or caulking materials for use with sheet metal ducts, the following products are acceptable:
1. Hilti CP 601s Elastomeric Firestop Sealant
  2. Hilti CP 606 Flexible Firestop Sealant
  3. Hilti FS-ONE Intumescent Firestop Sealant
  4. Hilti CP 604 Self-leveling Firestop Sealant
  5. Equivalent products listed in the U.L. Fire Resistance Directory – Volume 2
- E. Intumescent sealants or caulking materials for use with combustible items (penetrants consumed by high heat and flame) including insulated metal pipe, PVC jacketed, flexible cable or cable bundles and plastic pipe, the following products are acceptable:
1. Hilti FS-ONE Intumescent Firestop Sealant
  2. 3M Fire Barrier CP25 WB
  3. Tremco Tremstop WBM Intumescent Firestop Sealant
  4. Equivalent products listed in the U.L. Fire Resistance Directory – Volume 2
- F. Intumescent sealants, caulking or putty materials for use with flexible cable or cable bundles, the following products are acceptable:
1. Hilti FS-ONE Intumescent Firestop Sealant
  2. Hilti CP 620 Fire Foam
  3. Hilti CP 618 Firestop Putty Stick
  4. 3M Fire Barrier CP25 WB
  5. Tremco Tremstop WBM Intumescent Firestop Sealant
  6. Equivalent products listed in the U.L. Fire Resistance Directory – Volume 2
- G. Non curing, re-penetrable intumescent sealants, caulking or putty materials for use with flexible cable or cable bundles, the following products are acceptable:

1. Hilti CP 618 Firestop Putty Stick
  2. Equivalent products listed in the U.L. Fire Resistance Directory – Volume 2
- H. Wall opening protective materials for use with U.L. listed metallic and specified nonmetallic outlet boxes, the following products are acceptable:
1. Hilti CP 617 Firestop Putty Pad
  2. Equivalent products listed in the U.L. Fire Resistance Directory – Volume 1
- I. Firestop collar or wrap devices attached to assembly around combustible plastic conduit, the following products are acceptable:
1. Hilti CP 642 Firestop Collar
  2. Hilti CP 643 Firestop Collar
  3. 3M Fire Barrier PPD Plastic Pipe Device
  4. Hilti CP 645 Wrap Strip
  5. Equivalent products listed in the U.L. Fire Resistance Directory – Volume 2
- J. Materials used for large size/complex penetrations made to accommodate cable trays, multiple steel and copper pipes, electrical busways in raceways, the following products are acceptable:
1. Hilti CP 637 Firestop Mortar
  2. Hilti FS 657 FIRE BLOCK
  3. Hilti CP 620 Fire Foam
  4. 3M Firestop Foam 2001
  5. 3M Fire Barrier CS-195 Composite Sheet
  6. Equivalent products listed in the U.L. Fire Resistance Directory – Volume 2
- K. Non curing, re-penetrable materials used for large size/complex penetrations made to accommodate cable trays, multiple steel and copper pipes, electrical busways in raceways, the following products are acceptable:
1. Hilti FS 657 FIRE BLOCK
  2. Equivalent products listed in the U.L. Fire Resistance Directory – Volume 2
- L. Provide a firestop system with an "F" Rating as determined by UL 1479 or ASTM E814, which is equal to the time rating of construction being penetrated.

### **PART 3 – EXECUTION**

#### **3.1 PREPARATION**

- A. Verification of Conditions: Examine areas and conditions under which work is to be performed and identify conditions detrimental to proper or timely completion.
1. Verify penetrations are properly sized and in suitable condition for application of materials.
  2. Surfaces to which firestop materials will be applied shall be free of dirt, grease, oil, rust, laitance, release agents, water repellents, and any other substances that may affect proper adhesion.
  3. Provide masking and temporary covering to prevent soiling of adjacent surfaces by firestopping materials.
  4. Comply with manufacturer's recommendations for temperature and humidity conditions before, during and after installation of firestopping.
  5. Do not proceed until unsatisfactory conditions have been corrected.

#### **3.2 COORDINATION**

- A. Coordinate location and proper selection of cast-in-place Firestop Devices with trade responsible for the work. Ensure device is installed before placement of concrete.

- B. Responsible trade to provide adequate spacing of field run pipes to allow for installation of cast-in-place firestop devices without interferences.

### 3.3 INSTALLATION

- A. Regulatory Requirements: Install firestop materials in accordance with UL Fire Resistance Directory.
- B. Manufacturer's Instructions: Comply with manufacturer's instructions for installation of through-penetration and construction joint materials.
  - 1. Seal all holes or voids made by penetrations to ensure an air and water resistant seal.
  - 2. Protect materials from damage on surfaces subjected to traffic.

### 3.4 FIELD QUALITY CONTROL

- A. Examine sealed penetration areas to ensure proper installation before concealing or enclosing areas.
- B. Keep areas of work accessible until inspection by applicable code authorities.
- C. Inspection of through-penetration firestopping shall be performed in accordance with ASTM E 2174, "Standard Practice for On-Site Inspection of Installed Fire Stops" or other recognized standard.
- D. Perform under this section patching and repairing of firestopping caused by cutting or penetrating of existing firestop systems already installed by other trades.

### 3.5 ADJUSTING AND CLEANING

- A. Remove equipment, materials and debris, leaving area in undamaged, clean condition.
- B. Clean all surfaces adjacent to sealed holes and joints to be free of excess firestop materials and soiling as work progresses.

**END OF SECTION**

---

**SECTION 26 05 19 - LOW VOLTAGE ELECTRICAL POWER CONDUCTORS AND CABLES**

PART 1 – GENERAL

1.1 RELATED DOCUMENTS

- A. The Drawings and General Provisions of the Contract, including General and Supplementary Conditions and Division 01 Specification Sections, apply to the Work in this Section.

1.2 SUMMARY

- A. Provide all equipment, materials, labor, supervision, and services necessary for or incidental to the installation of conductors as indicated on the Drawings and as specified.
- B. Work included:
  - 1. Wiring connections and terminations, 600 Volt rating and below.
- C. **SUBMITTALS: Provide submittals as required in section 26 05 10, "Submittal Process."**

1.3 QUALITY ASSURANCE

- A. Use adequate numbers of skilled workers who are thoroughly trained and experienced in the necessary crafts and who are completely familiar with the specified requirements and the methods needed for proper performance of the work of this Section.
- B. Without additional cost to the Owner, provide such other labor and materials as are required to complete the work of this Section in accordance to the requirements of governmental agencies having jurisdiction, regardless of whether such materials and associated labor are called for elsewhere in these Contract Documents.
- C. When requested, provide the manufacturer's certifications that confirm that materials meet or exceed minimum requirements as specified.

PART 2 – PRODUCTS

2.1 CONDUCTORS

- A. Provide conductors made of soft-drawn, annealed copper with conductivity not less than that of 98% pure copper.
- B. Building Wire:
  - 1. Thermoplastic-insulated building wire: NEMA WC 5
  - 2. Feeders and branch circuits: Copper, stranded conductor, 600-volt insulation, THHN/THWN-2
  - 3. Control circuits: Copper, stranded conductor 600-volt insulation, THHN/THWN-2
  - 4. Where more than one conductor of the same phase or more than one neutral conductor occurs at the same outlet or junction box, these conductors shall be identifiable from each other by use of stripes or distinguishing markings

5. Type AC cables shall not be used
6. Use the following color code system:

	240/120 Volt Systems	208Y/120 Volt Systems	480Y/277 Volt Systems
Phase A	Black	Black	Brown
Phase B	Orange	Red	Orange
Phase C	Blue	Blue	Yellow
Neutral	White	White	Gray
Ground	Green	Green	Green
Switch	Purple	Purple	Purple

C. Remote Control and Signal Cable:

1. Control cable for Class 2 or Class 3 remote control and signal circuits: Copper conductor, 300-volt insulation, rated 60-degree C, individual conductors twisted together, shielded, and covered with a PVC jacket; UL listed.
2. Plenum cable for Class 2 or Class 3 remote control and signal circuits: Copper conductor, 300-volt insulation, rated 60-degree C, individual conductors twisted together, shielded, and covered with a nonmetallic jacket; UL listed for use in air handling ducts, hollow spaces used as ducts, and plenums.

2.2 ACCEPTABLE MANUFACTURERS

A. Provide products by the following manufacturers:

1. Rome
2. Cable
3. Pirelli
4. Belden
5. Or approved equal

PART 3 – EXECUTION

3.1 GENERAL WIRING METHODS (LESS THAN 600 VOLTS)

- A. Install conductor sizes as indicated. Provide No. 10 AWG conductor for the entire circuit length for single-phase, 20-ampere circuits for which the distance from panelboard to the last outlet is more than 100 feet for 120-volt circuits or 200 feet for 277-volt circuits. The minimum wire size shall be 12 AWG for power and lighting circuits, and no smaller than 18 AWG for control wiring. Remote control wiring shall not be less than 14 AWG for installed lengths of 50 feet or less. Remote control conductors shall be increased one size (per NEC Table 310) for each additional 50 feet of length. Increase the raceway system to accommodate the increased wire size.

- B. Provide an equal number of conductors of equal size for each phase of a circuit in same raceway or cable.
- C. Splice only in junction boxes, outlet boxes, pullboxes, or manholes.
- D. Neatly train and lace wiring inside boxes, equipment, and panelboards.
- E. Make conductor lengths for parallel circuits equal.
- F. Phasing shall be consistent throughout each installation from the service connection to every device connection and outlet. Where interface is made to an existing system, the existing phasing configuration shall be maintained.

### 3.2 WIRING INSTALLATION IN RACEWAYS

- A. Pull all conductors into a raceway at the same time. Use UL listed wire-pulling lubricant for pulling 4 AWG and larger wires.
- B. Install wire in raceway after interior of building has been physically protected from the weather and all mechanical work likely to injure conductors has been completed.
- C. Completely and thoroughly swab raceway system before installing conductors.

### 3.3 CABLE INSTALLATION

- A. Provide protection for exposed cables where subject to damage.
- B. Support cables above accessible ceilings. Do not rest on ceiling tiles, light fixtures or air devices. Use spring metal clips or metal cable ties to support cables from structure. Include bridle rings or drive rings.
- C. Use suitable cable fittings and connectors.

### 3.4 WIRING CONNECTIONS AND TERMINATIONS

- A. Splice only in accessible boxes or manholes.
- B. Use solderless pressure connectors with insulating covers for copper wire splices and taps 8 AWG and smaller.
- C. Use split bolt connectors for copper wire splices and taps 6 AWG and larger. Tape uninsulated conductors and connectors with electrical tape to 150 percent of the insulation value of conductor.
- D. Thoroughly clean wires before installing lugs and connectors.
- E. Make splices, taps and terminations to carry full capacity of conductors without perceptible temperature rise.
- F. Terminate spare conductors with electrical tape.



- G. Field Testing. Insulation resistance of all feeder conductors served by a protective device rated 200A or higher shall be tested. Each conductor shall have its insulation resistance tested after the installation is completed and all splices, taps and connections are made except connection to or into its source and point (or points) of termination. Insulation resistance of conductors which are to operate at 600 volts or less shall be tested by using a Biddle Megger of not less than 1000 volts d-c. Insulation resistance of conductors rated at 600 volts shall be free of shorts and grounds and have a minimum resistance phase-to-phase and phase-to-ground of at least 10 megohms. Conductors that do not exceed insulation resistance values listed above shall be removed at Contractor's expense and replaced and test repeated. The Contractor shall furnish all instruments and personnel required for tests, shall tabulate readings observed, and shall forward copies of the test readings to the Owner in accordance with Section 26 0593. These test reports shall identify each conductor tested, date and time of test and weather conditions. Each test shall be signed by the party making the test.

### 3.5 FIELD QUALITY CONTROL

- A. Field inspection and testing will be performed under applicable provisions of Division 26.
- B. Inspect wire and cable for physical damage and proper connection.
- C. Torque test conductor connections and terminations to manufacturers recommended values.
- D. Perform continuity tests on all power and equipment branch circuit conductors. Verify proper phasing of all connections.

### 3.6 WIRE AND CABLE INSTALLATION SCHEDULE

- A. All locations: Building wire in raceways.

### 3.7 600-VOLT INSULATED CONDUCTORS

- A. Size: Install conductor sizes as indicated. Provide No. 10 AWG conductor for the entire circuit length for single-phase, 20-ampere circuits for which the distance from panelboard to the last outlet is more than 100 feet for 120-volt circuits or 200 feet for 277-volt circuits.
- B. Home Runs: Except where specifically indicated, provide branch circuit home runs with not more than two different line conductors and a common neutral in a single raceway for 3-wire, single-phase systems, nor more than three different line conductors and a common neutral in a single raceway for 4-wire, 3-phase systems. Use home run circuit numbers as indicated for panelboard connections.
- C. Where more than one conductor of the same phase or more than one neutral conductor occurs at the same outlet or junction box, these conductors shall be identifiable from each other by use of stripes or distinguishing markings.

END OF SECTION

**SECTION 26 05 26 - GROUNDING AND BONDING FOR ELECTRICAL SYSTEMS**

**PART 1 – GENERAL**

**1.1 RELATED DOCUMENTS**

- A. The Drawings and General Provisions of the Contract, including General and Supplementary Conditions and Division 01 Specification Sections, apply to the Work in this Section.

**1.2 SUMMARY**

- A. Provide all equipment, materials, labor, supervision, and services necessary for or incidental to the installation of electrical systems grounding as shown or indicated on the Drawings and/or as specified.
- B. Work Included:
  - 1. Power systems grounding
  - 2. Electrical equipment and raceway grounding and bonding
- C. SUBMITTALS: **Provide submittals as required in section 26 05 10, “Submittal Process.”**

**1.3 QUALITY ASSURANCE**

- A. Use adequate numbers of skilled workmen who are thoroughly trained and experienced in the necessary crafts and who are completely familiar with the specified requirements and the methods needed for proper performance of the work of this Section.
- B. Without additional cost to the Owner, provide such other labor and materials as are required to complete the work of this Section in accordance with the requirements of governmental agencies having jurisdiction, regardless of whether such materials and associated labor are called for elsewhere in these Contract Documents.
- C. When requested, provide the Engineer with the manufacturer's certificate that materials meet or exceed minimum requirements as specified.

**PART 2 – PRODUCTS**

**2.1 MATERIALS**

- A. Provide electrical grounding system indicated with assembly of materials, including but not limited to:
  - 1. Wires and cables
  - 2. Connectors
  - 3. Terminals
  - 4. Ground rods
  - 5. Bonding jumper braid
  - 6. Surge arrestors
- B. Where materials or components are not indicated, provide products complying with NEC, UL, IEEE, and established industry standards for applications indicated.

## 2.2 CHEMICAL GROUND ROD

- A. Self-contained ground rod(s) using electrolytically enhanced grounding shall be provided for power system grounding where indicated on the drawings. The ground rod shall operate by hygroscopically extracting moisture from the air to activate the electrolytic process improving performance. The ground rod system shall be UL listed and have been manufactured for a minimum of 10 years. The ground rod system shall be 100% self activating sealed and maintenance free. The system shall not require the addition of chemical or water solutions.
- B. Electrode unit
  - 1. The copper ground rod shall consist of 2" nominal diameter hollow copper tube with a wall thickness of not less than .083". The tube shall be permanently capped on the top and bottom. Air breather holes shall be provided in the top of the tube and drainage holes shall be provided in the bottom of the tube for electrolyte drainage into the surrounding soil. Shaft configuration: Straight Shaft Model No: K2-1020CS; UL Listing: 467.
  - 2. The ground rod shall be filled from the factory with non-hazardous Calsolyte to enhance grounding performance.
  - 3. Ground rod shall be twenty feet long for straight (vertical) installation.
  - 4. A stranded 4/0 AWG Cu ground wire shall be Cadwelded to the side of rod for electrode conductor connection. A clamping "U-bolt" with pressure plate on the tip end of the tube shall be provided for testing and temporary connections.
- C. Ground Access Box
  - 1. Provide a precast concrete box with slots for conduit entrances. Minimum size shall be ten-inch diameter by twelve high. Provide a cast iron, flush traffic rated cover with "breather" slots, XIT model #XB-12.
- D. Backfill Material
  - 1. Natural volcanic, non-corrosive form of bentonite clay grout backfill material free of polymer sealant. XIT model #LNC.
  - 2. Shall absorb approximately 14 gallons of water per 50# bag for optimal 30% solids density.
  - 3. PH value 8-10 with maximum resistivity of 3 ohm-m at 30% solids density.
- E. Manufacturer: Lyncole XIT Grounding, 3547 Voyager St., Torrance, CA 90503, Phone (800) 962-2610; or approved equal.
- F. Ground Wire Termination: Exothermic connection to 4/0 conductor. U-bolt with pressure plate provided as test point.

## PART 3 – EXECUTION

### 3.1 INSTALLATION

- A. Install electrical grounding systems in accordance with applicable portions of NEC, with NECA's "Standard of Installation," and in accordance with recognized industry practices to ensure that products comply with requirements and serve intended functions.

- B. Provide a separate, insulated equipment grounding conductor in feeder circuits. Terminate each end on a grounding lug, bus, or bushing.
- C. Connect grounding electrode conductors to metal water pipe using a suitable ground clamp. Make connections to flanged piping at street side of flange. Provide bonding jumper around water meter.
- D. Installation of Chemical Ground Rod
  - 1. Install a supplemental ground rod system in compliance with manufacturer's instruction or recommendation.
  - 2. Bore minimum 6" diameter hole, 6" deeper than the length of rod to be buried. Insure that the top of the copper chemical ground rod will not come in contact with the metal grate of the protective box or hand-hole cover.
  - 3. Remove sealing tape from leaching holes
  - 4. Place chemical ground rod in hole, so that the top of unit is about 6" below grade.
  - 5. Backfill.
  - 6. Lynconite backfill is specific clay (bentonite clay) included with the system. Mix each 50# backfill grout material with 14 gallons water to form a slurry and pour around chemical ground rod up to "bury to here sticker".
  - 7. Place protective box in accordance with the drawings
  - 8. Remove sealing tape from the top breather holes to activate.
  - 9. Connect grounding electrode conductor to ground rod pigtail exothermically( Cadweld or Thermoweld).
  - 10. Bury grounding conductor 30" below grade. Cover conductor with a small amount of backfill for protection against corrosion.

### 3.2 FIELD QUALITY CONTROL

- A. Inspect grounding and bonding system conductors and connections for tightness and proper installation.
- B. Electrical Tests:
  - 1. Perform fall-of-potential test or alternative in accordance with IEEE Standard 81-1991 on the main grounding electrode or systems.
  - 2. Perform point-to-point tests to determine the resistance between the main grounding system and all major electrical equipment frames, system neutral, and/or derived neutral points.
- C. Test Values:
  - 1. The resistance between the main grounding electrode and ground should be no greater than two ohms. Install additional grounding electrodes, as required, to achieve the specified resistance value.
  - 2. Investigate point-to-point resistance values which exceed 0.5 ohm. Correct deficiencies at no additional cost. Retest to prove compliance
- D. Provide written certification to the Engineer that the grounding system has been tested and complies with the specified requirements.
- E. Provide a test report.

END OF SECTION

THIS PAGE WAS INTENTIONALLY LEFT BLANK

**SECTION 26 0529 - SUPPORTING DEVICES**

**PART 1 – GENERAL**

**1.1 RELATED DOCUMENTS**

- A. The Drawings and General Provisions of the Contract, including General and Supplementary Conditions and Division 01 Specification Sections, apply to the Work in this Section.

**1.2 SUMMARY**

- A. Provide all equipment, materials, labor, supervision, and services necessary for or incidental to the installation of support systems as shown or indicated on the Drawings and/or as specified.

- B. Work Included:
  - 1. Conduit and equipment supports
  - 2. Fastening hardware

- C. **SUBMITTALS: Provide submittals as required in section 26 05 10, "Submittal Process."**

**1.3 QUALITY ASSURANCE**

- A. Use adequate numbers of skilled workers who are thoroughly trained and experienced in the necessary crafts and who are completely familiar with the specified requirements and the methods needed for proper performance of the work of this Section.
- B. Without additional cost to the Owner, provide such other labor and materials as are required to complete the work in this Section in accordance with the requirements of governmental agencies having jurisdiction, regardless of whether such materials and associated labor are called for elsewhere in these Contract Documents.
- C. When requested, provide the Architect with manufacturer's certificates that confirm materials meet or exceed minimum requirements as specified.

**PART 2 – PRODUCTS**

**2.1 HANGERS AND CLAMPS**

- A. Provide supporting devices of types, sizes, and materials indicated, and having the following construction features:
  - 1. Clevis Hangers: For supporting 2" rigid metal conduit; galvanized steel; with 1/2" diameter hole for round steel rod, approximately 54 pounds per units.
  - 2. Riser Clamps: For supporting 5" rigid metal conduit; black steel; with 2 bolts and nuts, and 4" ears, approximately 510 pounds per 100 units.
  - 3. Reducing Couplings: Steel rod reducing coupling, 1/2" x 5/8", black steel, approximately 16 pounds per 100 units.
  - 4. C-Clamps: Black steel, 1-1/4" x 3/16" stock; 3/8" cross bolt; flange width 2", approximately 52 pounds per 100 units.
  - 5. I-Beam Clamps: Black steel, 1-1/4" x 3/16" stock; 3/8" cross bolt; flange width 2"; approximately 52 pounds per 100 units.

6. One-Hole Conduit Straps: For supporting 3/4" rigid metal conduit; galvanized steel; approximately 7 pounds per 100 units.
  7. Two-Hole Conduit Straps: For supporting 3/4" rigid metal conduit, galvanized steel; 3/4" strap width; and 2-1/8" between center of screw holes.
  8. Hexagon Nuts: For 1/2" rod size; galvanized steel; approximately 4 pounds per 100 units.
  9. Round Steel Rod: Black steel; 1/2" diameter; approximately 67 pounds per 100 feet.
  10. Offset Conduit Clamps: For supporting 2" rigid metal conduit; black steel; approximately 200 pounds per 100 units.
- B. Anchors: Provide anchors of types, sizes, and materials indicated, and having the following construction features:
1. Lead Expansion Anchors: 1/2", approximately 38 pounds per 100 units.
  2. Toggle Bolts: Springhead; 3/16" x 4"; approximately 5 pounds per 100 units.
- C. Sleeves and Seals: Provide sleeves and seals, of types, sizes and materials indicated; and having the following construction features:
1. Wall and Floor Seals: Provide factory-assembled watertight wall and floor seals, of types and sizes indicated; suitable for sealing around conduit, pipe, or tubing passing through concrete floors and walls. Construct with steel sleeves, malleable iron body, neoprene sealing grommets and rings, metal pressure rings, pressure clamps, and cap screws.
- D. Conduit Cable Supports: Provide cable supports with insulating wedging plug for non-armored type electrical cables in risers; construct for 2" rigid metal conduit; 3-wires, type wire as indicated; construct body of malleable iron casting with hot dip galvanized finish.
- E. U-Channel Strut Systems: Provide U-channel strut system for supporting electrical equipment, 16-gage hot dip galvanized steel, of types and sizes indicated; construct with 9/16" diameter holes, 8" O.C. on top surface, with standard green finish, and with the following fittings which mate and match with U-channel:
- |                          |                 |
|--------------------------|-----------------|
| Fixture hangers          | Channel hangers |
| End caps                 | Beam clamps     |
| Thin wall conduit clamps | Wiring stud     |
| Rigid conduit clamps     | Conduit hangers |
| U-bolts                  |                 |

## 2.2 FABRICATED SUPPORTING DEVICES

- A. Provide pipe sleeves of one of the following:
1. Sheet Metal: Fabricate from galvanized sheet metal; round tube closed with snaplock joint, welded spiral seams, or welded longitudinal joint. Fabricate from the following gages: 3" and smaller, 20 gauge; 4" to 6", 16 gauge; over 6", 14 gauge.
  2. Steel Pipe: Fabricate from Schedule 40 galvanized steel pipe, remove burrs.
  3. Iron Pipe: Fabricate from cast iron or ductile iron pipe; remove burrs.
  4. Plastic Pipe: Fabricate from Schedule 80 PVC plastic pipe; remove burrs.
- B. Sleeve Seals: Provide sleeve seals for sleeves located in foundation walls below grade, or in exterior walls, of one of the following:
1. Dow # 790 Silicone Building Sealant by Dow Corning Corporation.

## PART 3 – EXECUTION

**3.1 INSTALLATION OF SUPPORTING DEVICES**

- A. Fasten hanger rods, conduit clamps, and outlet and junction boxes to building structure using expansion anchors, preset inserts, or beam clamps.
- B. Install hangers, supports, clamps, and attachments to support piping properly from building structure. Arrange for grouping of parallel runs of horizontal conduits to be supported together on trapeze type hangers where possible. Install supports with maximum spacing indicated.
- C. Use toggle bolts or hollow wall fasteners in hollow masonry, plaster, or gypsum board partitions and walls; expansion anchors or present inserts in solid masonry walls; self-drilling anchors or expansion anchor on concrete surfaces; sheet metal screws in sheet metal studs; and wood screws in wood construction.
- D. Do not fasten supports to piping, ductwork, mechanical equipment, or conduit.
- E. Fabricate supports from structural steel or steel channel, rigidly welded or bolted to present a neat appearance. Use hexagon head bolts with spring lock washers under all nuts.
- F. Install freestanding electrical equipment on concrete pads.
- G. Install surface-mounted cabinets and panelboards with minimum of four anchors.
- H. Bridge studs top and bottom with channels to support surface and flush-mounted cabinets and panelboards in stud walls.
- I. Tighten sleeve seal nuts until sealing grommets have expanded to form watertight seal.

END OF SECTION



THIS PAGE INTENTIONALLY LEFT BLANK

---

**SECTION 26 05 33.13 - CONDUIT FOR ELECTRICAL SYSTEMS**

**PART 1 – GENERAL**

**1.1 RELATED DOCUMENTS**

- A. The Drawings and General Provisions of the Contract, including General and Supplementary Conditions and Division 01 Specification Sections, apply to the Work in this Section.

**1.2 SUMMARY**

- A. Provide all equipment, materials, labor, supervision, and services necessary for or incidental to the installation of a complete and operating electrical raceway system, as indicated on the Drawings and as specified.
- B. Work included:
  - 1. Rigid metal conduit and fittings
  - 2. Electrical metallic tubing and fittings
  - 3. Flexible metal conduit and fittings
  - 4. Non-metallic conduit and fittings
  - 5. Surface-mounted raceway
- C. **SUBMITTALS: Provide submittals as required in section 26 05 10, "Submittal Process."**

**1.3 QUALITY ASSURANCE**

- A. Use adequate numbers of skilled workers who are thoroughly trained and experienced in the necessary crafts and who are completely familiar with the specified requirements and the methods needed for proper performance of the work of this Section.
- B. Without additional cost to the Owner, provide such other labor and materials as are required to complete the work of this Section in accordance to the requirements of governmental agencies having jurisdiction, regardless of whether such materials and associated labor are called for elsewhere in these Contract Documents.
- C. When requested, provide the Architect with manufacturer's certificates that confirm that materials meet or exceed minimum requirements as specified.

**PART 2 – PRODUCTS**

**2.1 CONDUITS AND FITTINGS**

- A. Provide metal conduits, tubing, fittings, and couplings of types, grades, sizes, and weights (wall thickness) for each service indicated. Where types and grades are not indicated, provide proper selection determined by installer to fulfill wiring requirements and comply with applicable portions of NEC for raceways.
- B. Rigid Metal Conduit and Fittings
  - 1. Rigid steel conduit: ANSI C80.1
  - 2. Fittings and conduit bodies: ANSI/NEMA FB 1; threaded type, material to match conduit.

- C. Electrical Metallic Tubing (EMT) and Fittings
  - 1. EMT: ANSI C80.3 galvanized tubing
  - 2. Fittings and Conduit Bodies: ANSI/NEMA FB 1; steel compression type
- D. Flexible Metal Conduit and Fittings
  - 1. Conduit: FS WW-C-566; steel
  - 2. Fittings and Conduit Bodies: ANSI/NEMA FB 1
- E. Liquid tight Flexible Conduit and Fittings
  - 1. Conduit: Flexible metal conduit with PVC jacket
  - 2. Fittings and Conduit Bodies: ANSI/NEMA FB 1
- F. Plastic Conduit and Fittings
  - 1. Conduit: NEMA TC 2; Schedule 40 PVC
  - 2. Fittings and Conduit Bodies: NEMA TC 3

## 2.2 CONDUIT SUPPORTS

- A. Conduit Clamps, Straps, and Supports: Steel or malleable iron.

## PART 3 – EXECUTION

### 3.1 CONDUIT SIZING, ARRANGEMENT AND SUPPORT

- A. Size of conduit shall be as indicated on the drawings or sized for conductor type installed, whichever is larger. Size all conduits in accordance with the NEC. Minimum conduit size shall be  $\frac{3}{4}$  inch.
- B. Arrange conduit to maintain headroom and present a neat appearance.
- C. Route exposed conduit and conduit above accessible ceilings parallel and perpendicular to walls and adjacent piping.
- D. Maintain minimum 6-inch clearance between conduit and piping. Maintain 12-inch clearance between conduit and heat sources such as flues, steam pipes, and heating appliances.
- E. Arrange conduit supports to prevent distortion of alignment by wire pulling operations. Fasten conduit using galvanized straps, lay-in adjustable hangers, clevis hangers, or bolted split stamped galvanized hangers.
- F. Group conduit in parallel runs where practical and use conduit rack constructed of steel channel with conduit straps or clamps.
- G. Do not fasten conduit with wire or perforated pipe straps. Remove all wire used for temporary conduit support during construction, before conductors are pulled.

### 3.2 CONDUIT INSTALLATION

- A. Cut conduit square using a saw or pipe cutter; de-burr cut ends.
- B. Bring conduit to the shoulder of fittings and couplings and fasten securely.

- C. Use conduit hubs for fastening conduit to cast boxes and for fastening conduit to sheet metal boxes in damp or wet locations.
- D. Install no more than the equivalent of three 90-degree bends between boxes.
- E. Use conduit bodies to make sharp changes in direction, as around beams.
- F. Use hydraulic one-shot conduit bender or factory elbows for bends in conduit larger than 2-inches in size.
- G. Avoid moisture traps where possible; where unavoidable, provide junction box with drain fitting at conduit low point.
- H. Use suitable conduit caps to protect installed conduit against entrance of dirt and moisture.
- I. Provide a pull tape for spare empty conduits. The tape shall be fiberglass reinforced polyester tape with distance marking in feet continuous along its length. Furnish T&B or Greenlee products.
- J. Install expansion joints where conduit crosses building expansion joints.
- K. Where conduit penetrates fire-rated walls and floors, provide mechanical firestop fittings with UL listed fire rating equal to wall or floor rating. Seal opening around conduit with UL listed foamed silicone elastomer compound.
- L. Route conduit through roof openings for piping and ductwork where possible; otherwise route through roof jack with pitch pocket.
- M. Maximum size conduit in slabs above grade: 3/4 inch.
- N. Use PVC-coated rigid steel factory elbows for bends in plastic conduit runs longer than 100 feet or in plastic conduit runs, which have more than two bends regardless of length.
- O. Make joints in accordance with manufacturers' written instructions.
- P. Provide plastic warning tape for underground conduit or duct bank installations. Install warning tape directly above conduit one foot below finished grade or as shown on drawings.
- Q. Sand for intermediate fill around underground conduits shall be washed sand, suitable for concrete or masonry. Reference Section 26 0500 for additional backfill and excavation requirements.

### 3.3 CONDUIT INSTALLATION SCHEDULE

- A. Underground installations more than two feet from foundation wall: Rigid steel conduit or Schedule 40 plastic conduit.
- B. Installations in or under concrete slab, or underground within 2 feet of foundation wall: Rigid steel conduit.
- C. In slab above grade: Rigid steel conduit.
- D. Exposed outdoor locations: Rigid steel conduit.

E. Wet interior locations: Rigid Steel Conduit.

F. Concealed dry interior locations: Electrical metallic tubing.

G. Exposed dry interior locations: Electrical metallic tubing.

**3.4 CONDUIT IN DETENTION AREAS**

A. Conduits shall be concealed in CMU walls.

B. Conduits shall be concealed in concrete walls and ceilings.

C. conduits may be exposed in electric rooms, mechanical rooms and plumbing chases.

**END OF SECTION**

**SECTION 26 0533.16 - BOXES FOR ELECTRICAL SYSTEMS**

**PART 1 – GENERAL**

**1.1 RELATED DOCUMENTS**

- A. The Drawings and General Provisions of the Contract, including General and Supplementary Conditions and Division 01 Specification Sections, apply to the Work in this Section.

**1.2 SUMMARY**

- A. Provide all equipment, materials, labor, supervision, and services necessary for or incidental to the installation of outlets, pull and junction boxes as indicated on the Drawings and specified.
- B. Work included:
  - 1. Wall and ceiling outlet boxes
  - 2. Pull and junction boxes

**1.3 QUALITY ASSURANCE**

- A. Use adequate numbers of skilled workers who are thoroughly trained and experienced in the necessary crafts and who are completely familiar with the specified requirements and the methods needed for proper performance of the work of this Section.
- B. Without additional cost to the Owner, provide such other labor and materials as are required to complete the work of this Section in accordance with the requirements of governmental agencies having jurisdiction, regardless of whether such materials and associated labor are called for elsewhere in these Contract Documents.
- C. When requested, provide the Engineer with manufacturer's certificates that confirm that materials meet or exceed minimum requirements as specified.

**1.4 SUBMITTALS**

- A. **Provide submittals as required in section 26 05 10, "Submittal Process."**

**PART 2 – PRODUCTS**

**2.1 BOXES**

- A. Provide standard, stamped galvanized steel boxes except as hereinafter noted, by Steel City or approved equal.
- B. Outlet Boxes
  - 1. Sheet Metal Outlet Boxes: ANSI/NEMA OS 1; galvanized steel, with 1/2 inch male fixture studs where required.
  - 2. Cast Boxes: Aluminum or cast ferroalloy, deep type, gasket and cover, threaded hubs.

C. Pull and Junction Boxes

1. Sheet metal boxes: ANSI/NEMA OS 1, galvanized steel.
2. Cast metal boxes for outdoor and wet location installation shall be NEMA 250, Type 4 and Type 6, flat-flanged, surface-mounted junction boxes, UL listed as rain tight. Galvanized cast iron or cast aluminum box and cover with ground flange, neoprene gasket, and stainless steel cover screws.
3. Cast Metal Boxes for Underground Installations: NEMA 250 Type 4, outside flanged, recessed cover box for flush mounting, UL listed as raintight. Galvanized cast iron or cast aluminum box and plain cover with neoprene gasket and stainless steel cover screws.

2.2 FLOOR BOXES

A. Combination Flush Floor Boxes

1. Where indicated in plan, furnish and install Wiremold/Walker Resource RFB series four compartment floor boxes.
2. Boxes located on the First Floor shall be Cast Iron, with a maximum depth of 3-7/16".
3. Boxes located on the Second Floor shall be Shallow Stamped Steel, with a maximum depth of 2-7/16".

PART 3 – EXECUTION

3.1 COORDINATION OF BOX LOCATIONS

- A. Provide electrical boxes as shown on Drawings, and as required for splices, taps, wire pulling, equipment connections, and code compliance.
- B. Electrical box locations shown on Contract Drawings are approximate unless dimensioned.
- C. Locate and install boxes to allow access.
- D. Locate and install to maintain headroom and to present a neat appearance.

3.2 OUTLET BOX INSTALLATION

- A. Do not install boxes back-to-back in walls. Provide a minimum 6-inch separation between boxes. Provide a minimum 24-inch separation between boxes in acoustic-rated walls.
- B. Locate boxes in masonry walls to require cutting of masonry unit corner only. Coordinate masonry cutting to achieve neat openings for boxes.
- C. Provide knockout closures for unused openings.
- D. Support boxes securely and independently of conduit.
- E. Use multiple gang boxes where more than one device is mounted together. Do not use sectional boxes. Provide barriers to separate wiring of different voltage systems.
- F. Install boxes in walls without damaging wall insulation.

- G. Coordinate mounting heights and locations of outlets mounted above counters, benches, and backsplashes.
  - H. Position outlets to locate luminaires as shown on reflected ceiling plans.
  - I. In inaccessible ceiling areas, position outlets and junction boxes within 6 inches of recessed luminaire, to be accessible through luminaire ceiling opening.
  - J. Provide recessed outlet boxes in finished areas; secure boxes to interior wall and partition studs, accurately positioning to allow for surface finish thickness. Use stamped steel stud bridges for flush outlets in hollow stud wall, and adjustable steel channel fasteners for flush ceiling outlet boxes.
  - K. Align wall-mounted outlet boxes for switches, thermostats, and similar devices.
  - L. Provide cast outlet boxes in exterior locations and wet locations.
- 3.3 PULL AND JUNCTION BOX INSTALLATION
- A. Locate pull boxes and junction boxes above accessible ceilings or in unfinished areas.
  - B. Support pull and junction boxes independent of conduit.
  - C. Set underground pull and junction boxes level and flush with finished grade.

END OF SECTION



THIS PAGE INTENTIONALLY LEFT BLANK

**SECTION 26 0553  
IDENTIFICATION FOR ELECTRICAL SYSTEMS**

PART 1 – GENERAL

1.1 RELATED DOCUMENTS

- A. The Drawings and General Provisions of the Contract, including General and Supplementary Conditions and Division 01 Specification Sections, apply to the Work in this Section.

1.2 SUMMARY

- A. Provide all equipment, materials, labor, supervision, and services necessary for or incidental to the installation of identification for electrical equipment as shown or as specified.
- B. Work Included:
  - 1. Nameplates and tape labels
  - 2. Wire and cable markers
  - 3. Buried conduit markers

- B. SUBMITTALS: **Provide submittals as required in section 26 05 10, "Submittal Process."**

1.3 QUALITY ASSURANCE

- A. Use adequate numbers of skilled workers who are thoroughly trained and experienced in the necessary crafts and who are completely familiar with the specified requirements and the methods needed for proper performance of the work of this Section.
- B. Without additional cost to the Owner, provide such other labor and materials as are required to complete the work of this Section in accordance to the requirements of governmental agencies having jurisdiction, regardless of whether such materials and associated labor are called for elsewhere in these Contract Documents.
- C. When requested, provide the manufacturer's certificates that confirm that materials meet or exceed minimum requirements as specified.

PART 2 – PRODUCTS

2.1 MATERIALS

- A. Nameplates: Engraved three-layer laminated plastic, white letters on a black background.
- B. Wire and Cable Markers: Cloth markers, split sleeve or tubing type.
- C. Buried Conduit Marker: Continuous printed plastic tape.
- D. Outdoor Equipment Cables: Manufacturer's Standards
  - 1. Weather and sun resistant
  - 2. Vandal resistant

**2.2 EQUIPMENT AND RACEWAYS OVER 600 VOLTS**

- A. Provide "WARNING - HIGH VOLTAGE - KEEP OUT" signs on all equipment. With 2-inch high lettering, mark exposed raceways containing conductors operating in excess of 600 volts every 100 feet with the words "WARNING - HIGH VOLTAGE".

**2.3 SPECIAL RACEWAY IDENTIFICATION**

- A. Special Systems. Brady Series 55200, 2" wide, pipe banding tape or colored conduit.
  - 1. Fire alarm: red
  - 2. Telephone: blue
  - 3. Data/Communications: blue
  - 4. Low voltage controls: black
  - 5. Sound systems: yellow
  - 6. Clock systems: green

**2.4 WIRE AND CABLE MARKERS**

- A. Lighting and Power Circuit Wire Markers.
  - 1. Sizes #12 through 3/0 AWG. Brady SCN clip-sleeve wire markers.
  - 2. Sizes 4/0 AWG and larger. Brady HSA heat shrink sleeves, custom printed.
  - 3. Legends. Panel and circuit description; for example "EP1-1", "E1 - 2", "LPA-14".

**2.5 EQUIPMENT AND WIRING DEVICE NAMEPLATES**

- A. General: White core laminated plastic. White lettering on black background, same style throughout project.
- B. Emergency Equipment Nameplates: White lettering on red background.
- C. Fasteners: Stainless steel self-tapping screws. Use epoxy adhesive only when NEMA enclosure rating is compromised by screws and for wiring device nameplates.
- D. Switchboard, Motor Control Center, Panelboard, Dry-type Transformer and Control Panel Main Nameplate: 5/8" high block letters.
- E. Other Nameplates: 3/8" high block or condensed letters.
- F. Legends:
  - 1. General. Description as indicated on drawings, i.e., "PANEL EP-1", "XFRM ET-1", "TS-1".
  - 2. Voltage. Description of operating voltage, i.e., "120 Volts", "120/208 Volts", "208 Volts", "277/480 Volts", or "480 Volts", "Single Phase" or "Three Phase".
  - 3. Source: Description of source; i.e., "FED FROM PANEL EP-1, CKT. #1".
  - 4. Available fault current and data calculated.
- G. AIC Rating: Short Circuit current rating, fully rated; i.e., "10,000 Amperes, Fully Rated",

**2.6 PANELBOARD CIRCUIT BREAKER IDENTIFICATIONS**

- A. Manufacturer's standard labels supplied with panelboard.

- B. AIC Rating: Short circuit current rating, fully rated; i.e. "10,000 Amperes, Fully Rated".

## 2.7 EQUIPMENT CONTROL PANEL NAMEPLATES

- A. White core laminated plastic. White lettering on black background, same style throughout, 3/8" high block or condensed letters.
- B. Legends:
  - 1. Manufacturer's Short Circuit Current Rating (SCCR).

## 2.8 TERMINAL IDENTIFICATIONS

- A. Brady B-500 vinyl cloth pre-printed self-adhesive terminal markers. Legends: 1 through 96, A through Z.

## 2.9 FUSE IDENTIFICATION LABELS

- A. Obtain original label from fuse box or carton or from fuse manufacturer, indicating manufacturer's name, fuse type, voltage and ampere rating. Attach with contact cement.

## 2.10 GROUND TERMINAL AND BUS IDENTIFICATION

- A. Type: Green paint or dye, factory applied to terminal and bus.
- B. Self-Adhesive Label Legend: "Ground", "Ground Bus", "Equipment Ground Bus" or "Isolated Ground Bus."

## 2.11 EMERGENCY FIXTURE AND OUTLET IDENTIFICATION

- A. Self-adhesive red vinyl dots, 1/4" diameter. Brady QD-25-RD.

## 2.12 CONCEALED EQUIPMENT IDENTIFICATION

- A. Brady ceiling tacks, 7/8" diameter with 7/16" long point.
  - 1. Electrical equipment: #23255 (orange).
  - 2. Fire alarm equipment: #23252 (red).

## 2.13 UNDERGROUND DUCT RUNS

- A. Brady "Identoline" 6" wide over coated polyethylene film 3.5 mils thick, underground warning tapes.
  - 1. Electric line: #91296 (red)
  - 2. Telephone line: #91297 (orange)
  - 3. Customized: Orange
    - a. Fire alarm line
    - b. Communications line
    - c. Data line
    - d. Data/communications line
    - e. Security line
    - f. CCTV line

2.14 DUCT RUN MARKERS

- A. General.
  - 1. Construction: Class A concrete.
  - 2. Size: 6 inches square or round, 24 inches long. 45° chamfer on top edges.
  - 3. Markings: Impressed or cast Letter "D" and two arrows. Locate one arrow below letter, pointing to duct run. Locate second arrow at right of letters, pointing parallel to duct run.
  - 4. Marking sizes: V-shaped 1/4" wide at surface and 1/4" deep. 3" long for letter and arrow to right. 2" long for arrow below letter.
- B. Change of Direction Markers: Angle arrow to right of letter to correspond to angular change of duct run direction.

2.15 DISTRIBUTION TRANSFORMER WARNING SIGN

- A. Construction: Indoor/outdoor type, plastic or fiber glass, non-corrosive, impervious to weather.
- B. Legend: "Danger" upper legend, white block letters on red panel on black panel. "High Voltage" lower legend, black condensed block letters on white.
- C. Manufacturer: Brady, #71565.
- D. Size: 7 inches high x 10 inches wide.

2.16 GENERATOR WARNING SIGNS

- A. Construction: Indoor/outdoor type. Plastic or fiber glass, non-corrosive, impervious to weather.
- B. Legend: "Danger" upper legend white block letters on red panel on black panel. "Warning" middle legend, red block letters on white panel, underlined in red. "This machine is automatically controlled" lower middle legend, black condensed block letters on white panel. "It may start at any time" bottom legend, red block letters on white panel.
- C. Manufacturer: Brady, #47161.
- D. Size: 7 inches high x 10 inches wide.

PART 3 – EXECUTION

3.1 GENERAL

- A. Install nameplates, signs and labels, and engraved wall plates parallel to equipment lines. Embossed tape will not be permitted for any application.

3.2 INSTALLATION

- A. Degrease and clean surfaces to receive nameplates.
- B. Install nameplates parallel to equipment lines.

- C. Secure nameplates to equipment fronts using stainless steel screws. Secure nameplate to inside face of recessed panelboard doors in finished locations.
- D. Outdoor equipment labels shall be installed by the manufacturer as specified.

### 3.3 WIRE IDENTIFICATION

- A. Provide wire markers on each conductor in panelboard gutters, pull boxes, and junction boxes, and at load connection. Identify with branch circuit or feeder number for power and lighting circuits, and with control wire number as indicated on equipment manufacturer's shop drawings for control wiring.

### 3.4 NAMEPLATE ENGRAVING SCHEDULE

- A. Provide nameplates to identify all electrical distribution and control equipment, and loads served. Letter Height: 1/4 inch for individual switches and loads served, 1/4 inch for distribution and control equipment identification.

### 3.5 EQUIPMENT NAMEPLATES

- A. General: Identify panelboards, dry-type transformers and control panels with nameplates showing descriptions or designations on Drawings.
- B. Identify disconnect and transfer switches with nameplates describing loads served and panelboard circuit controlling load.
- C. Identify conduits, connected to pull and junction boxes, with nameplates describing the complete circuit number of the conductors contained in each conduit.
- D. Identify receptacles, where the nominal voltage between contact pairs is greater than 150 volts, with nameplates describing the complete circuit number, voltage, and phases.
- E. Identify wall switches, where the equipment served is not in sight of the wall switch, with nameplates describing the equipment served by the wall switches.
- F. Locations.
  - 1. Switchboards, Motor Control Centers, Distribution Panelboards. Locate main nameplate in center over top wiring gutter. Locate individual nameplates for switches and starters centrally on device doors. Locate individual nameplates adjacent and to the side of circuit breakers.
  - 2. Lighting and Appliance Panelboards. Locate main nameplate in center of cover approximately 2" down from top of panel.
  - 3. Dry-type transformers. In middle of front cover panel.
  - 4. Receptacles and Wall Switches. On wall directly above device plate.
  - 5. Other equipment: In middle near top of equipment.

### 3.6 PANELBOARD CIRCUIT BREAKER IDENTIFICATIONS

- A. General. Attach numbered identification to each panelboard circuit breaker in space provided by manufacturer.

- B. Sequence. Arrange numbering to correspond to panelboard pole positions. For two pole breakers, number according to the upper pole only. For three pole breakers, number according to middle pole only. For multiple breakers occupying poles on both left and right side, number according to left side only.
- C. Numbering Convention. Number poles from top to bottom. Utilize consecutive odd numbers for left side and consecutive even numbers for right side.
- D. Separate Sub-feed Breakers. Number with last number of panelboard sequence.
- E. Circuit Directory. Prepare a neatly typed circuit directory behind clear heat resistant plastic in a metal frame attached to the inside of the door for each panelboard. Identify circuits by equipment served and by room numbers where room numbers exist. Indicate spares and spaces with light, erasable pencil marking. An adhesive mounted directory pocket is not acceptable.

**3.7 BURIED CONDUIT OR DIRECT BURIED CABLE IDENTIFICATION**

- A. Underground-Type Plastic Line Marker: Manufacturer's standard permanent, bright-colored, continuous-printed plastic tape, intended for direct-burial service; not less than 6" wide x 4 mils thick.
- B. Provide tape with printing of "Buried Electrical Conduit" or other similar warning. Install directly above buried conduit or cable one half the distance to conduit below finished grade.

END OF SECTION

**SECTION 26 06 20 - DISCONNECT SWITCHES**

**PART 1 – GENERAL**

**1.1 RELATED DOCUMENTS**

- A. The General Provisions of the Contract, including General and Supplementary Conditions, apply to the Work specified in this Section.

**1.2 RELATED WORK SPECIFIED ELSEWHERE**

- A. All other Sections of Division 26.
- B. All other Divisions of the Contract Documents. Refer to each Division's Specifications and Drawings for requirements.

**1.3 SCOPE**

- A. Provide all equipment, materials, labor, supervision, and services necessary for or incidental to the installation of disconnect switches as shown or indicated on the Drawings and/or as specified.
- B. Work Included:
  - 1. Circuit disconnects
  - 2. Motor disconnects

**1.4 SUBMITTALS**

- A. Provide submittals as required in section 26 05 10, "Submittal Process."**

**1.5 QUALITY ASSURANCE**

- A. Use adequate numbers of skilled workers who are thoroughly trained and experienced in the necessary crafts and who are completely familiar with the specified requirements and the methods needed for proper performance of the work of this Section.
- B. Without additional cost to the Owner, provide such other labor and materials as are required to complete the work of this Section in accordance to the requirements of governmental agencies having jurisdiction, regardless of whether such materials and associated labor are called for elsewhere in these Contract Documents.
- C. When requested, provide the Architect with manufacturer's certificate that materials meet or exceed minimum requirements as specified.

**PART 2 – PRODUCTS**

**2.1 ACCEPTABLE MANUFACTURERS**

- A. Provide disconnect switches manufactured by one of the following:



1. General Electric Company
2. Siemens Energy and Automation
3. Square D Schneider Electric
4. Eaton, Cutler Hammer

## 2.2 HEAVY-DUTY SAFETY SWITCHES

- A. Provide surface-mounted, heavy-duty type, sheet-steel enclosed safety switches, of types, sizes and electrical characteristics indicated; fusible type, rated 600 volts, and incorporating quick-make, quick-break type switches; construct so that switch blades are visible in OFF position with door open. Equip with operating handle which is pad lockable in OFF position; construct current carrying parts of high-conductivity copper, with silver-tungsten type switch contacts, and positive pressure type reinforced fuse clips. Provide NEMA Type 3R enclosures at exterior equipment..

## 2.3 COMPONENTS

- A. Motor and circuit disconnects shall have an Underwriters' Laboratory label.
- B. Single Phase Disconnect Switches: Two pole toggle switch equal to Square D Type F with thermal overloads in appropriate enclosure.
- C. Three Phase Motor Disconnect Switches: 3 pole heavy duty 250 or 600 volt as required in NEMA Type 1 or 3 enclosures as indicated and as required.
- D. Enclosures
  1. Normal indoor locations – heavy duty NEMA 1
  2. Outdoor or wet locations – heavy duty NEMA 3R

## PART 3 – EXECUTION

### 3.1 INSTALLATION

- A. Install circuit and motor disconnect switches as indicated, complying with manufacturer's written instructions, applicable requirements of NEC, NEMA, and NECA's "Standard of Installation", and in accordance with recognized industry practices.

END OF SECTION



MD Engineering, LP, LLP  
500 North Central Expressway  
Suite 310  
Plano, TX 75074  
P: 469-467-0200  
F: 469-467-0300

### MEP ABBREVIATIONS

ABV.	ABOVE
AC	ALTERING CURRENT
A/C	AIR CONDITIONER
AFC	ABOVE FINISHED CEILING
AFI	ABOVE FINISHED FLOOR
AFG	ABOVE FINISHED GRADE
AG	ABOVE GRADE AND GFI
AG	AS HIGH AS POSSIBLE
AHU	AIR HANDLING UNIT
ALT.	ALTERNATE
AMB.	AMBIENT TEMPERATURE (F. DEGREE)
AMP	AMPERE
APPROX.	APPROXIMATELY
ARCH.	ARCHITECTURAL
AVG.	AVERAGE
B	BOILER
B.G.	BELOW GRADE
BMS	BUILDING MANAGEMENT SYSTEM
BRD	BAROMETRIC RELIEF DAMPER
BTU	BRITISH THERMAL UNIT
CD	CONSTRUCTION DOCUMENTS
CFH	CUBIC FEET PER HOUR
CFM	CUBIC FEET PER MINUTE
CH	CHILLER
CHEM	CHEMICAL
CHP	CHILLED WATER PUMP
CKT	CIRCUIT
CLG	CEILING
CMPR	COMPRESSOR
CT	COOLING TOWER
CWP	CONDENSER WATER PUMP
CU	CONDENSING UNIT
DB	DRY BULB
DEFL	DEFLECTION
DEG. F	DEGREES FAHRENHEIT
DET.	DETAIL
DD	DESIGN DEVELOPMENT
DIAM	DIAMETER
DISC.	DISCONNECT SWITCH
DM	DIMENSION
EA	EXHAUST AIR
EDB	ENTERING DRY BULB
EF	EXHAUST FAN
ELEC.	ELECTRICAL
ELEV.	ELEVATION
EMCS	ENERGY MGMT. CONTROL SYSTEM
E.S.P.	EXTERNAL STATIC PRESS. (IN W.G.)
EWB	ENTERING WET BULB
EWI	ENTERING WATER TEMPERATURE
EXH	EXHAUST
EXIST	EXISTING
FA	FREE AREA OPENING (SQ. FT.)
FCO	FLOOR CLEAN OUT
FCU	FAN COIL UNIT
FHP	FRACTIONAL HORSE POWER
FLR.	FLOOR
FP	COIL FEET PER INCH
FFM	FEET PER MINUTE
FPS	FEET PER SECOND
FT	FOOT OR FEET
GFI	GROUND FAULT INTERRUPTER
GPM	GALLONS PER MINUTE
HD	HEAD
HOA	HANDS/OFF/AUTO. MOTOR STARTER
HP	HORSE POWER
HRU	HEAT RUMP UNIT
HR	HOUR(S)
HT	HEIGHT
HTG	HEATING
HTR	HEATER
HVAC	HEAT, VENT AND AIR CONDITIONING
HWP	HOT WATER PUMP
HX	HEAT EXCHANGER
HZ	FREQUENCY (HERTZ)
ID	INSIDE DIAMETER OR DIMENSION
IN.	INCHES
KW	KILOWATT
KWH	KILOWATT HOUR
LAT	LEAVING AIR TEMPERATURE
LWT	LEAVING WATER TEMPERATURE
MAX.	MAXIMUM
MCA	MINIMUM CURRENT AMPS
MOCIP	MAX. OVER CURRENT PROTECTION
MBH	1000 BTU PER HOUR
MECH.	MECHANICAL
MFR.	MANUFACTURER
MIN.	MINIMUM
MVD	MANUAL VOLUME DAMPER
N/A	NOT APPLICABLE
NC	NOISE CRITERIA
NIC	NOT IN CONSTRUCTION
NK	NECK DIMENSION
NO.	NUMBER
OA	OUTSIDE AIR
OAR	OWNER'S AUTHORIZED REPRESENTATIVE
OSD	OPPOSED SLIDE DAMPER
OD	OUTSIDE DIAMETER
OFCI	OWNER FURNISHED CONTRACTOR INSTALLED
ORIG.	ORIGINAL
P.D.	PRESSURE DROP (FT)
PH.	PHASE
PHB	POWERED MIXING BOX
PLBG	PLUMBING
PNL	PANEL
PRESS	PRESSURE
RA	RETURN AIR
RA3	RETURN AIR GRILLE
RD	RADIUS
RE.	REFERENCE
RPM	REVOLUTIONS PER MINUTE
RTU	ROOF TOP UNIT
S/S	SINGLE SPEED MOTOR
S/S/S	START/STOP/STATUS
SA	SUPPLY AIR
SAG	SUPPLY AIR GRILLE
SDC	STAND ALONE DIGITAL CONTROLLER
SEER	SEASON ENERGY EFFICIENCY RATIO
SENS.	SENSIBLE
SP	STATIC PRESSURE
SQ.	SQUARE
STR.	MOTOR STARTER
TEMP.	TEMPERATURE
T.S.P.	TOTAL STATIC PRESSURE (IN W.G.)
UH	UNIT HEATER
UNO	UNLESS NOTED OTHERWISE
V	VOLT
VAV	VARIABLE AIR VALVE
VEL.	VELOCITY
W.	WATT
WI.	WITH
W/O	WITHOUT
W.G.	WATER GAUGE
WB	WET BULB
WCO	WALL CLEAN OUT
WP	WEATHERPROOF
WPD	WATER PRESSURE DROP
WPG	WEATHERPROOF GFI
XMR.	TRANSFORMER

### DUCTWORK LEGEND

16X12	SHEET METAL DUCT	
	DIRECTION OF FLOW	
=====	INTERNALLY INSULATED SHEET METAL DUCT	
-----	HIDDEN SHEET METAL DUCT	
	ROUND ELBOW DOWN (R/A SIMILAR)	
	ROUND ELBOW UP (R/A SIMILAR)	
	RADIUS ELBOW (R=1.5 MIN.)	
	45 DEGREE ELBOW (R=1.5 MIN.)	
	TEE OR SHAPE TRANSITION	
	TURNING VANES (RECTANGULAR), SMOOTH RADIUS	
	FLEXIBLE DUCT CONN. W/DAMPERS	
	BRANCH TAKE-OFF	
	WYE JUNCTION	
	SUPPLY DUCT SECTION UP	
	SUPPLY DUCT SECTION DOWN	
	RETURN DUCT SECTION UP	
	RETURN DUCT SECTION DOWN	
	EXHAUST DUCT SECTION UP	
	90 DEGREE S/A ELBOW DOWN	
	90 DEGREE S/A ELBOW UP	
	90 DEGREE R/A ELBOW DOWN	
	EXHAUST DUCT SECTION DOWN	
	90 DEGREE R/A ELBOW UP	
	RADIUS ELBOW (R=1.5 MIN.)	
	SQUARE ELBOW WITH DOUBLE WALL TURNING VANES	
	BRANCH TAKE-OFF WITH VANED EXTRACTOR	
	SPIN-IN TAP WITH DAMPER	
	TEE WITH SQUARE ELBOWS, TURNING VANES & SPLITTER DAMPER	
	SIDEWALL SUPPLY GRILLE OR REGISTER WITH AIR EXTRACTOR	
	S/A GRILLE/REGISTER W SQUARE NECK, 4-WAY THROW (U.N.O.)	
	R/A GRILLE OR REGISTER	
	VOLUME DAMPER	
	COUNTER WEIGHTED BACKDRAFT DAMPER	
	FIRE DAMPER	
	FIRE/SMOKE DAMPER (WITH SM. DET.)	
	SMOKE DAMPER (WITH SM. DET.)	
	MOTORIZED DAMPER	
	STATIC PRESSURE SENSOR	
	AIRFLOW MEASURE STATION	
	AIRFLOW IONIZER STATION	
	THERMOSTAT OR TEMP SENSOR/HUMIDISTAT/CARBON DIOXIDE SENSOR	
	ACCESS DOOR	
	DUCT MOUNTED SMOKE DETECTOR (TUBE SENSING TYPE)	

ALL SYMBOLS ON THIS LIST ARE NOT NECESSARILY USED ON THIS PROJECT.

### HVAC & PLUMBING, VALVE & FITTINGS SYMBOLS

	TEE
	TEE, UP
	TEE, DOWN
	SINGLE SWEEP TEE
	CROSS
	LATERAL
	45 DEGREE ELBOW
	90 DEGREE ELBOW
	90 DEGREE ELBOW UP
	90 DEGREE ELBOW DOWN
	CAP
	SINGLE W.F. LATERAL STUB
	DOUBLE W.F. LATERAL STUB
	SINGLE W.F. LAT. & TRAP
	DOUBLE W.F. LAT & TRAP
	FLOOR DRAIN RISER W/TRAP
	FLOOR CLEAN OUT
	CLEAN OUT
	FLOOR DRAIN
	HUB DRAIN
	DOWN SPOUT
	FIRE HOSE CABINET
	VENT THRU ROOF
	OVERFLOW ROOF DRAIN
	ROOF DRAIN
	GAS PRESSURE REDUCING VALVE
	CHECK VALVE
	OS & Y VALVE
	GLOBE VALVE
	GATE VALVE
	BALANCING VALVE (WITH PETE'S PLUG EITHER SIDE)
	BUTTERFLY VALVE
	BALL VALVE
	SOLENOID VALVE
	PLUG VALVE
	PRESSURE REDUCING VALVE
	PRESSURE RELIEF VALVE
	CONTROL, 2 WAY VALVE
	CONTROL, 3 WAY VALVE
	MOTORIZED ISOLATION VALVE (2-POSITION-24V)
	MOTORIZED CONTROL VALVE (MODULATING-24V)
	FLOOR CONTROL VALVE
	ANGLE GATE VALVE
	ANGLE GLOBE VALVE
	MANUALLY CALIBRATED BALANCING VALVE
	AUTOMATIC FLOW CONTROL VALVE
	STRAINER & BLOW OFF VALVE
	PRESSURE GAUGE & COCK
	UNION OR COMPANION FLANGES
	THERMOMETER
	PRESSURE & TEMPERATURE TAP (PETE'S PLUG)
	THERMOSTAT
	HUMIDISTAT
	FLOW METER
	ANCHOR (PIPE)
	EXPANSION JOINT
	PIPE GUIDE
	MANUAL AIR VENT
	AUTOMATIC AIR VENT
	HOSE END DRAIN
	HOSE BIBB
	THERMOMETER & WELL
	TEMPERATURE SENSOR
	FLOW SWITCH
	PRESSURE SENSOR
	COMPRESSED AIR TAP
	FLOAT AND THERM. TRAP
	BUCKET STEAM TRAP
	PIPE SIZE REDUCER (CONCENTRIC)
	PIPE SIZE REDUCER (ECCENTRIC)

ALL SYMBOLS ON THIS LIST ARE NOT NECESSARILY USED ON THIS JOB.

### FIRE PROTECTION SYMBOLS

	FLOW SWITCH
	POST INDICATOR VALVES (PIV)
	OPEN SCREW AND YOKE VALVE (OS&Y)
	FIRE DEPARTMENT CONNECTION
	UP AND DOWN SPRINKLER AT SAME LOCATION
	UP SPRINKLER
	SYSTEM RISER
	HOSE VALVE (ANGLE VALVE)
	RISE UP ON PIPING
	DROP IN PIPING
	TAMPER SWITCH FOR VALVES
	PENDANT SPRINKLER
	UPRIGHT SPRINKLER OR RISE (SPRIG)
	PENDANT SPRINKLER ON DROP
	SIDEWALL SPRINKLER

### GENERAL HVAC NOTES:

- ALL CONDUIT IN FINISHED ROOMS OR SPACES SHALL BE CONCEALED WITHIN FURRED CHASES OR ABOVE SUSPENDED CEILING.
- CONTRACTOR SHALL VERIFY THE EQUIPMENT CLEARANCE REQUIREMENTS WITH THE MANUFACTURER'S RECOMMENDATIONS. EXACT LOCATION OF SELECTED EQUIPMENT SHALL BE COORDINATED WITH THE EXISTING MECHANICAL EQUIPMENT AND DUCTWORK TO PROVIDE RECOMMENDED CLEARANCES FOR MAINTENANCE.
- VERIFY THAT ALL EXISTING MECHANICAL EQUIPMENT MAINTAIN UNOBSTRUCTED MAINTENANCE ACCESS FOR ALL PANELS, CONTROLS AND CONDUIT.
- THE INSTALLING CONTRACTOR SHALL DEMO THE PNEUMATIC ACTUATOR ONLY AFTER THE ELECTRICAL INFRASTRUCTURE TO THE NEW ELECTRONIC ACTUATOR IS IN PLACE IN AN EFFORT TO REDUCE OPERATIONAL DOWN TIME OF THE EXISTING HVAC SYSTEMS AND LIFE SAFETY SYSTEMS.
- THIS CONTRACTOR SHALL REPORT AND REPAIR ANY DEFICIENCIES FOUND IN THE EXISTING EQUIPMENT IN AN EFFORT TO PROVIDE THE OWNER WITH A FULLY OPERATIONAL HVAC, LIFE SAFETY AND DDC CONTROLS SYSTEM.
- AFTER THE NEW ELECTRONIC ACTUATOR IS INSTALLED ON AN EXISTING DAMPER, THE INSTALLING CONTRACTOR SHALL CHECK THE OPERATIONAL SIGNAL TO THE DDC SYSTEM TO CONFIRM THE POINT(S) AND TO ADJUST/CALIBRATE THE DAMPER / ACTUATOR LINKAGE ACCORDINGLY. THE DAMPER SHALL THEN BE CYCLED AND VISUALLY INSPECTED FOR COMPLIANCE WITH THE EXISTING LIFE SAFETY AND NORMAL SEQUENCES OF OPERATION.

### GENERAL PROJECT NOTES:

- PROVIDE ALL MATERIALS AND EQUIPMENT AND PERFORM ALL LABOR REQUIRED TO INSTALL COMPLETE AND OPERABLE MECHANICAL SYSTEM AS INDICATED ON THE DRAWINGS, AS SPECIFIED AND AS REQUIRED BY ALL NATIONAL, STATE AND LOCAL CODES.
- CONTRACT DRAWINGS FOR MECHANICAL WORK (HVAC, AND FIRE PROTECTION) ARE DIAGRAMMATIC AND ARE INTENDED TO CONVEY SCOPE AND GENERAL ARRANGEMENT ONLY. IT IS THE CONTRACTOR'S RESPONSIBILITY FOR INSTALLING ALL MATERIALS PER SMANACA AND THE MANUFACTURER'S STANDARDS.
- COORDINATE INSTALLATION OF ALL MECHANICAL WORK WITH ELECTRICAL WORK, ETC., SHOWN ON THE OTHER CONTRACT DRAWINGS.
- WHEN TWO OR MORE ITEMS OF THE SAME TYPE OF EQUIPMENT ARE REQUIRED, THE PRODUCT OF ONE MANUFACTURE SHALL BE USED.
- ALL CONTROL WIRE AND CONDUIT SHALL COMPLY WITH THE LATEST EDITION NATIONAL ELECTRIC CODE AND DIVISION 16 (23) OF THE SPECIFICATION.
- ALL MISCELLANEOUS STEEL REQUIRED TO ENSURE PROPER INSTALLATION AND AS SHOWN IN DETAILS FOR PIPING AND EQUIPMENT (UNLESS OTHERWISE NOTED) SHALL BE FURNISHED AND INSTALLED BY THE MECHANICAL CONTRACTOR.
- PRESSURIZED LIQUID, GAS, AIR SYSTEM PIPE AND ELECTRICAL CONDUIT SHALL NOT BE ROUTED BENEATH ANY SUSPENDED EQUIPMENT, FIRE PROTECTION, ELECTRICAL AND MECHANICAL CONTRACTORS SHALL COORDINATE TRADES.

### GENERAL HVAC DEMOLITION NOTES

- REFER TO MP 0.0 FOR GENERAL MECHANICAL NOTES, ABBREVIATIONS AND SYMBOLS.
- REFER TO SPECIFICATION DIVISIONS 01 AND 02 FOR DEMOLITION REQUIREMENTS AND PROCEDURES.
- TOUR THE PROJECT SITE WITH THE OWNER'S REPRESENTATIVE TO IDENTIFY AND MARK THOSE ITEMS SCHEDULED FOR DEMOLITION THAT THE OWNER WISHES TO RETAIN. DELIVER THOSE ITEMS SO MARKED, TO THE OWNER'S STORAGE, WITHIN THE PROJECT SITE AS DIRECTED.
- ALL REMAINING DEMOLITION ITEMS SHALL BECOME THE CONTRACTOR'S PROPERTY AND SHALL BE REMOVED FROM THE SITE. HAZARDOUS MATERIALS SHALL BE DISPOSED OF IN ACCORDANCE WITH FEDERAL REGULATIONS AND THE CONTRACT DOCUMENTS.
- REMOVE PNEUMATIC ACTUATORS AND APPURTENANCES, SEAL PNEUMATIC PIPING SYSTEMS AND REMOVE ANY DEVICES, CONTROLS, CONDUIT, UNISTRUT, ALL THREAD, WIRE CLIPS AND HANGERS WITHIN AREA OF WORK UNLESS NOTED OTHERWISE. FLOOR STRUCTURE SHOULD BE CLEAN AND CLEAR OF ANY DEMOLITION DEBRIS.
- THE MECHANICAL SERVICE TO AREAS NOT WITHIN THE DEMOLITION SCOPE OF WORK SHALL NOT LOSE FUNCTION UNLESS SCHEDULED AND AGREED TO BY THE OWNER.
- CONTRACTOR SHALL LEAVE THE DEMISED AREAS IN A CLEAN AND ORDERLY CONDITION.
- ALL DEMOLITION ACTIVITIES SHALL BE PERFORMED SO AS TO PROVIDE MINIMAL DISRUPTION TO NORMAL FACILITY OPERATIONS.
- ALL HVAC EQUIPMENT AND DUCTWORK (INCLUDING DAMPERS) ARE EXISTING TO REMAIN.

### PIPING DESIGNATIONS

(ALL DESIGNATIONS MAY NOT APPEAR ON DRAWINGS.)

SYMBOL	DESCRIPTION
	SANITARY SEWER
	SUBSOIL DRAIN PIPING
	STORM DRAIN
	OVERFLOW DRAIN
	PLUMBING VENT
	DOMESTIC COLD WATER
	DOMESTIC HOT WATER (120 F)
	DOMESTIC HOT WATER RECIRC.
	DOMESTIC HOT WATER (140 F)
	FIRE LINE
	BRANCH FIRE LINE WITH SPRINKLER HEADS
	MEDIUM PRESSURE NATURAL GAS LINE
	LOW PRESSURE NATURAL GAS LINE
	REFRIGERANT LIQUID LINE
	REFRIGERANT SUCTION LINE
	CONDENSATE DRAIN LINE (HVAC)
	PUMPED CONDENSATE
	REFRIGERANT SUCTION & LIQUID LINES
	REFRIG. SUCTION, LIQUID, HOT GAS LINES

### DRAWING SYMBOLS

(ALL SYMBOLS MAY NOT APPEAR ON DRAWINGS)

SYMBOL	DESCRIPTION
	DIRECTION OF FLOW
	EQUIP. OR FIXTURE DRAIN LINE
	PRESSURE RELIEF DISCHARGE
	EXISTING PIPING
	EXISTING PIPING TO BE REMOVED
	UNDERFLOOR
	CONNECT TO NEW OR EXISTING
	CONDENSER WATER SUPPLY
	CONDENSER WATER RETURN
	CHILLED WATER SUPPLY
	CHILLED WATER RETURN
	TEMPERED CHILLED WATER SUPPLY
	TEMPERED CHILLED WATER RETURN
	HOT WATER FOR HEATING SUPPLY
	HOT WATER FOR HEATING RETURN
	DISCHARGE DRAIN

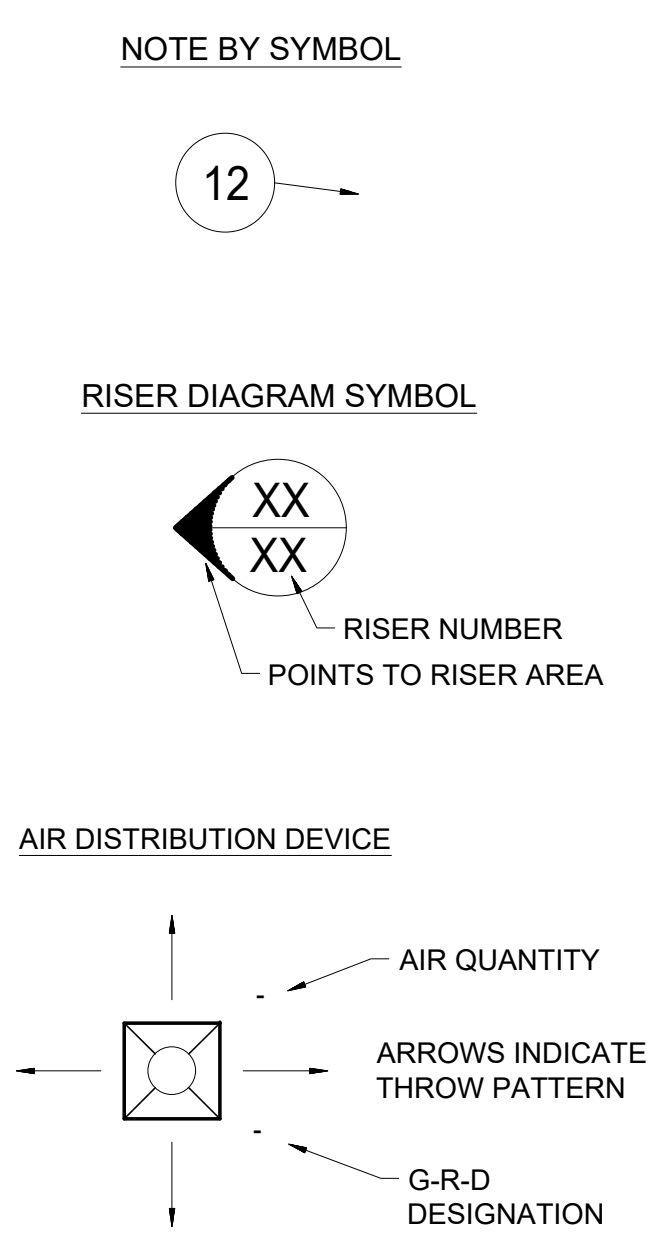
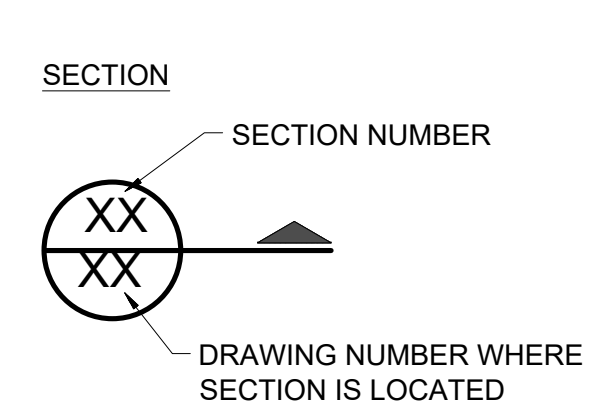
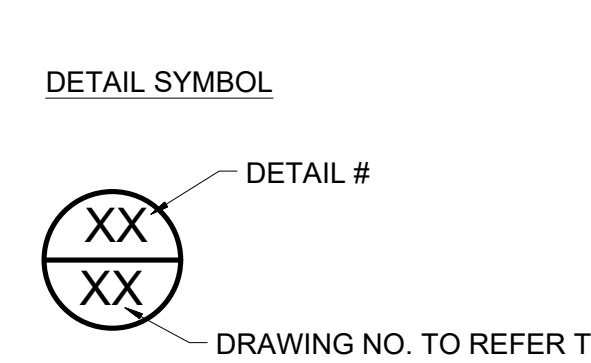
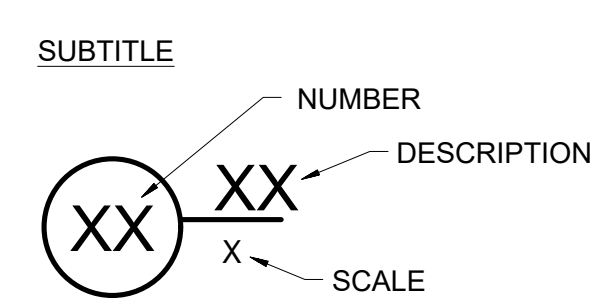

Texas Registered Firm No. F-7489  
500 North Central Expressway, Suite 310  
Ft. Worth, TX 76104  
Email: mlabarca@mdeng.com  
Project Number: 17939

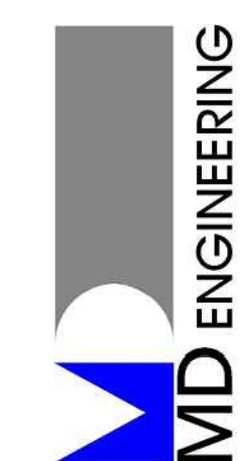

Collin County Justice Center  
Upgrade Pneumatic to Electronic Actuators  
4300 Community Ave. McKinney, Texas 75071

Revisions:	DATE	DESCRIPTION



MECHANICAL LEGEND

Project No.  
**17939**

Sheet No.  
**MO.0**

**CONTROL DAMPER SCHEDULE - AREA 'B' (EXISTING)**

DESIG	LOCATION	ASSOC EQUIP	SERVICE	TYPE	DAMPER SIZE (IN)			AREA SQ. FT.	FAIL CLOSED (N.C.)	FAIL OPEN (N.O.)	NUMBER EXIST. ACTUATORS	REMARKS
					BLADE LENGTH	HEIGHT	DIAMETER					
2B-AD-1	AREA B, LEVEL 2, MECH B2001	AHU-3.4	CA	REC / HORIZ	20	20		2.78		X	1	SEE NOTES
2B-AD-2	AREA B, LEVEL 2, MECH B2001	AHU-3.4	CA	REC / HORIZ	40	20		5.56		X	1	SEE NOTES
2B-AD-3	AREA B, LEVEL 2, MECH B2001	AHU-3.4	CA	REC / HORIZ	64	20		8.89		X	1	SEE NOTES
1B-AD-4	AREA B, LEVEL 1, RM B1307 N	SF-1B1	SA	REC / HORIZ	29	29		5.84		X	1	SEE NOTES
1B-AD-5	AREA B, LEVEL 1, RM B1307 NC	EF-1B8	EA	REC / HORIZ	38	38		10.03		X	1	SEE NOTES
1B-AD-6	AREA B, LEVEL 1, RM B1307 SC	EF-1B9	EA	REC / HORIZ	38	38		10.03		X	1	SEE NOTES
1B-AD-7	AREA B, LEVEL 1, RM B1307 S	SF-1B10	SA	REC / HORIZ	29	29		5.84		X	1	SEE NOTES
0B-AD-8	AREA B, LEVEL LL, MECH B0165	AHU-2	CA	REC / HORIZ	50	18		6.25		X	1	SEE NOTES
0B-AD-9	AREA B, LEVEL LL, MECH B0165	AHU-2	CA	REC / HORIZ	50	18		6.25		X	1	SEE NOTES
0B-AD-10	AREA B, LEVEL LL, MECH B0165	EF-0B4	EA	REC / VERT	18	14		1.75		X	1	SEE NOTES
0B-AD-11	AREA B, LEVEL LL, MECH B0165	EF-0B3	EA	REC / VERT	24	20		3.33		X	1	SEE NOTES
0B-AD-12	AREA B, LEVEL LL, MECH B0151	AHU-2	SA	RND / VERT			18	1.77	X		1	SEE NOTES
0B-AD-13	AREA B, LEVEL LL, MECH B0133	AHU-2	SA	REC / VERT	26	18		3.25		X	1	SEE NOTES
0B-AD-14	AREA B, LEVEL LL, MECH B0110	AHU-2	SA	REC / VERT	22	12		1.83		X	1	SEE NOTES
0B-AD-15	AREA B, LEVEL LL, MECH B0151	EF-0B5	EA	REC / VERT	14	14		1.36		X	1	SEE NOTES
1B-SD-1	AREA B, LEVEL 1, RM B1115	EF-1B	EA	REC / VERT	9	9		0.56	X		1	SEE NOTES
1B-SD-2	AREA B, LEVEL 1, RM B1115	AHU-4	SA	REC / VERT	8	8		0.44	X		1	SEE NOTES
1B-SD-3	AREA B, LEVEL 1, RM B1103	AHU-4	RA	REC / VERT	9	9		0.56	X		1	SEE NOTES
1B-SD-4	AREA B, LEVEL 1, RM B1103	AHU-4	SA	RND / VERT			16	1.40	X		1	SEE NOTES
1B-SD-5	AREA B, LEVEL 1, RM B1109	AHU-4	RA	REC / VERT	24	14		2.33	X		1	SEE NOTES
1B-SD-6	AREA B, LEVEL 1, RM B1330	AHU-4	SA	REC / VERT	20	20		2.78	X		1	SEE NOTES
1B-SD-7	AREA B, LEVEL 1, RM B1330	AHU-3	RA	REC / VERT	12	8		0.67	X		1	SEE NOTES
1B-SD-8	AREA B, LEVEL 1, RM B1331	AHU-3	SA	REC / VERT	8	8		0.44	X		1	SEE NOTES
1B-SD-9	AREA B, LEVEL 1, RM B1332	AHU-3	RA	REC / VERT	8	8		0.44	X		1	SEE NOTES
1B-SD-10	AREA B, LEVEL 1, RM B1329	AHU-3	SA	REC / VERT	8	8		0.44	X		1	SEE NOTES
1B-SD-11	AREA B, LEVEL 1, RM B1329	AHU-3	RA	REC / VERT	8	8		0.44	X		1	SEE NOTES
1B-SD-12	AREA B, LEVEL 1, RM B1116	AHU-4	RA	REC / VERT	24	14		2.33	X		1	SEE NOTES
1B-SD-13	AREA B, LEVEL 1, RM B1116	AHU-4	SA	RND / VERT			16	1.40	X		1	SEE NOTES
1B-SD-14	AREA B, LEVEL 1, RM 1350	AHU-4	SA	OVL / VERT	31	18		3.88	X		1	SEE NOTES
1B-SD-15	AREA B, LEVEL 1, RM 1350	AHU-4	RA	REC / VERT	34	20		4.72	X		1	SEE NOTES
1B-SD-16	AREA B, LEVEL 1, RM 1350	AHU-4	SA	REC / VERT	12	10		0.83	X		1	SEE NOTES
1B-SD-17	AREA B, LEVEL 1, RM 1336	EF-1B8	EA	RND / VERT			6	0.20	X		1	SEE NOTES
1B-SD-18	AREA B, LEVEL 1, RM 1336	AHU-3	SA	REC / VERT	9	8		0.50	X		1	SEE NOTES
1B-SD-19	AREA B, LEVEL 1, RM 1336	AHU-3	SA	REC / VERT	22	12		1.83	X		1	SEE NOTES
1B-SD-20	AREA B, LEVEL 1, RM 1336	AHU-3	SA	REC / VERT	8	12		0.67	X		1	SEE NOTES
1B-SD-21	AREA B, LEVEL 1, RM 1336	AHU-3	RA	REC / VERT	8	12		0.67	X		1	SEE NOTES
1B-SD-22	AREA B, LEVEL 1, RM 1307	AHU-4	RA	REC / VERT	40	16		4.44	X		1	SEE NOTES
1B-SD-23	AREA B, LEVEL 1, RM 1307	AHU-4	RA	REC / VERT	26	16		2.89	X		1	SEE NOTES
1B-SD-24	AREA B, LEVEL 1, RM 1343	AHU-4	SA	OVL / VERT	23	18		2.88	X		1	SEE NOTES
1B-SD-25	AREA B, LEVEL 1, RM 1343	AHU-4	RA	REC / VERT	26	18		3.25	X		1	SEE NOTES
1B-SD-26	AREA B, LEVEL 1, RM	AHU-4	SA	REC / VERT	16	16		1.78	X		1	SEE NOTES
2B-SD-27	AREA B, LEVEL 2, MECH B 2001	AHU-4	SA	REC / HORIZ	31	18		3.88	X		1	SEE NOTES
2B-SD-28	AREA B, LEVEL 2, MECH B 2001	AHU-4	RA	REC / HORIZ	32	18		4.00	X		1	SEE NOTES
2B-SD-29	AREA B, LEVEL 2, MECH B 2001	AHU-3	SA	REC / HORIZ	22	12		1.83	X		1	SEE NOTES
2B-SD-30	AREA B, LEVEL 2, MECH B 2001	AHU-3	SA	REC / HORIZ	22	18		2.75	X		1	SEE NOTES - NO VIS I.D.
2B-SD-31	AREA B, LEVEL 2, MECH B 2001	AHU-3	SA	REC / HORIZ	28	14		2.72	X		1	SEE NOTES - NO VIS I.D.
2B-SD-32	AREA B, LEVEL 2, MECH B 2001	AHU-3	SA	REC / HORIZ	22	12		1.83	X		1	SEE NOTES - NO VIS I.D.
2B-SD-33	AREA B, LEVEL 2, MECH B 2001	AHU-3	SA	REC / HORIZ	14	12		1.17	X		1	SEE NOTES
2B-SD-34	AREA B, LEVEL 2, MECH B 2001	AHU-3	SA	REC / HORIZ	14	12		1.17	X		1	SEE NOTES
2B-SD-35	AREA B, LEVEL 2, MECH B 2001	AHU-4	RA	REC / HORIZ	20	20		2.78	X		1	SEE NOTES
2B-SD-36	AREA B, LEVEL 2, B 2001 E CORR	AHU-4	RA	REC / VERT	60	18		7.50	X		1	SEE NOTES
2B-SD-37	AREA B, LEVEL 2, B 2001 E CORR	AHU-4	RA	REC / VERT	40	14		3.89	X		1	SEE NOTES
2B-SD-38	AREA B, LEVEL 2, B 2001 E CORR	AHU-4	SA	REC / VERT	14	8		0.78	X		1	SEE NOTES
2B-SD-39	AREA B, LEVEL 2, B 2001 E CORR	AHU-4	SA	REC / VERT	14	8		0.78	X		1	SEE NOTES
2B-SD-40	AREA B, LEVEL 2, B 2001 E CORR	AHU-4	TA	REC / VERT	48	22		7.33	X		1	SEE NOTES
2B-SD-41	AREA B, LEVEL 2, B 2001 E CORR	AHU-4	TA	REC / VERT	48	22		7.33	X		1	SEE NOTES
2B-SD-42	AREA B, LEVEL 2, B 2001 E CORR	AHU-4	SA	OVL / VERT	24	18		3.00	X		1	SEE NOTES
2B-SD-43	AREA B, LEVEL 2, MECH B 2001	AHU-4	SA	REC / VERT	24	8		1.33	X		1	SEE NOTES
2B-SD-44	AREA B, LEVEL 2, MECH B 2001	AHU-4	SA	REC / VERT	12	12		1.00	X		1	SEE NOTES
1B-SD-45	AREA B, LEVEL 2, MECH B 2001	AHU-3	RA	REC / HORIZ	50	18		6.25	X		1	SEE NOTES
1B-SD-46	AREA B, LEVEL 1, RM 1341	EF-1B8	EA	REC / VERT	8	10		0.56	X		1	SEE NOTES
1B-SD-47	AREA B, LEVEL 1, RM 1341	AHU-3	SA	REC / VERT	8	8		0.44	X		1	SEE NOTES
1B-SD-48	AREA B, LEVEL 1, RM 1341	AHU-4	RA	REC / VERT	26	18		3.25	X		1	SEE NOTES
1B-SD-49	AREA B, LEVEL 1, RM 1341	AHU-4	SA	REC / VERT	24	18		3.00	X		1	SEE NOTES
1B-SD-50	AREA B, LEVEL 1, RM B1349	AHU-4	SA	OVL / VERT	31	18		3.88	X		1	SEE NOTES
1B-SD-51	AREA B, LEVEL 1, RM B1349	AHU-4	SA	REC / VERT	10	12		0.83	X		1	SEE NOTES
1B-SD-52	AREA B, LEVEL 1, RM B1349	AHU-4	SA	OVL / VERT	31	18		3.88	X		1	SEE NOTES
1B-SD-53	AREA B, LEVEL 1, RM B1326	AHU-3	RA	REC / VERT	48	18		6.00	X		1	SEE NOTES
1B-SD-54	AREA B, LEVEL 1, RM B 1326	AHU-3	SA	REC / VERT	8	8		0.44	X		1	SEE NOTES
1B-SD-55	AREA B, LEVEL 1, RM B 1326	AHU-3	SA	REC / VERT	8	8		0.44	X		1	SEE NOTES
1B-SD-56	AREA B, LEVEL 1, RM B 1326	AHU-3	RA	REC / VERT	10	10		0.69	X		1	SEE NOTES
1B-SD-57	AREA B, LEVEL 1, RM B 1319	AHU-3	SA	REC / VERT	14	8		0.78	X		1	SEE NOTES
1B-SD-58	AREA B, LEVEL 1, RM B 1319	AHU-3	SA	REC / VERT	14	12		1.17	X		1	SEE NOTES
1B-SD-59	AREA B, LEVEL 1, RM B 1319	AHU-3	SA	REC / VERT	8	8		0.44	X		1	SEE NOTES
1B-SD-60	AREA B, LEVEL 1, RM B1332	AHU-3	RA	REC / VERT	10	8		0.56	X		1	SEE NOTES
1B-SD-61	AREA B, LEVEL 1, RM 1350	AHU-3	SA	REC / VERT	12	10		0.83	X		1	SEE NOTES
1B-SD-62	AREA B, LEVEL 1, RM B1117	AHU-4	SA	REC / VERT	8	8		0.44	X		1	SEE NOTES
1B-SD-63	AREA B, LEVEL 2, CORR B2002	AHU-4	SA	REC / VERT	12	12		1.00	X		2	SEE NOTES

ACTUATOR SUM = 79  
 NOTES  
 1. DESIGNATION: 1-2-3 : 1=BUILDING LEVEL / AREA ; 2=AD (AUTO DMPR) / SD (SMOKE DMPR) ; 3=DAMPER I.D. NUMBER  
 2. SERVICE : OA=OUTSIDE AIR ; SA=SUPPLY AIR ; RA=RETURN AIR ; RE=RELIEF AIR ; EA=EXHAUST AIR ; TA=TRANSFER AIR  
 3. ALL DAMPER ACTUATORS ARE CURRENTLY PNEUMATIC AND ARE TO BE CHANGED TO ELECTRONIC.

**CONTROL DAMPER SCHEDULE - AREA 'A' (EXISTING)**

DESIG	LOCATION	ASSOC EQUIP	SERVICE	TYPE	DAMPER SIZE (IN)			AREA SQ. FT.	FAIL CLOSED (N.C.)	FAIL OPEN (N.O.)	NUMBER EXIST. ACTUATORS	REMARKS
					BLADE LENGTH	HEIGHT	DIAMETER					
2A-AD-1	AREA A, LEVEL 2, MECH A2001	HD-2A1	CA	REC / HORIZ	20	20		2.78		X	1	SEE NOTES
2A-AD-2	AREA A, LEVEL 2, MECH A2001	AHU-1	CA	REC / HORIZ	96	18		12.00		X	2	SEE NOTES
2A-AD-3	AREA A, LEVEL 2, MECH A2001	AHU-1	RE	REC / HORIZ	44	20		6.11	X		1	SEE NOTES
1A-AD-4	AREA A, LEVEL 1, RM 1220	HD-1A1	OA	REC / HORIZ	48	48		16.00		X	1	SEE NOTES- MU AIR
2A-SD-1	AREA A, LEVEL 2, MECH A2001	AHU-1	SA	REC / HORIZ	15	13		1.35	X		1	SEE NOTES
2A-SD-2	AREA A, LEVEL 2, MECH A2001	AHU-1	RA	REC / HORIZ	24	24		4.00	X		1	SEE NOTES
2A-SD-3	AREA A, LEVEL 2, MECH A2001	AHU-1	SA	REC / HORIZ	13	11		0.99	X		1	SEE NOTES
2A-SD-4	AREA A, LEVEL 2, MECH A2001	AHU-1	SA	REC / HORIZ	26	16		2.89	X		1	SEE NOTES - NO VIS I.D.
2A-SD-5	AREA A, LEVEL 2, MECH A2001	AHU-1	SA	REC / HORIZ	36	16		4.00	X		1	SEE NOTES
2A-SD-6	AREA A, LEVEL 2, MECH A2001	AHU-1	RA	REC / HORIZ	34	20		4.72	X		1	SEE NOTES
2A-SD-7	AREA A, LEVEL 2, MECH A2001	AHU-1	SA	REC / HORIZ	20	12		1.67	X		1	SEE NOTES - NO VIS I.D.
2A-SD-8	AREA A, LEVEL 2, MECH A2001	AHU-1	SA	REC / VERT	14	12		1.17	X		1	SEE NOTES
2A-SD-9	AREA A, LEVEL 2, MECH A2001	AHU-1	RA	REC / VERT	18	12		1.50	X		1	SEE NOTES
2A-SD-10	AREA A, LEVEL 2, RM 2000A	AHU-1	SA	REC / VERT	12	12		1.00	X		1	SEE NOTES
2A-SD-11	AREA A, LEVEL 2, RM 2000A	AHU-1	SA	REC / VERT	12	12		1.00	X		1	SEE NOTES
2A-SD-12	AREA A, LEVEL 2, RM 2000A	AHU-1	TA	REC / VERT	12	12		1.00	X		1	SEE NOTES
1A-SD-13	AREA A, LEVEL 1, RM A1204	AHU-1	TA	REC / VERT	12	8		0.50	X		1	SEE NOTES
1A-SD-14	AREA A, LEVEL 1, RM A1204	AHU-1	SA	REC / VERT	10	10		0.69	X		1	SEE NOTES
1A-SD-15	AREA A, LEVEL 1, RM A1204	EF-1A3	EA	REC / VERT	9	9		0.56	X		1	SEE NOTES
1A-SD-16	AREA A, LEVEL 1, RM A1204	EF-1A3	EA	REC / VERT	9	9		0.56	X		1	SEE NOTES
1A-SD-17	AREA A, LEVEL 1, RM A1204	AHU-1	SA	REC / VERT	9	9		0.56	X		1	SEE NOTES
1A-SD-18	AREA A, LEVEL 1, RM A1208	AHU-1	RA	REC / VERT	12	12		1.00	X		1	SEE NOTES
1A-SD-19	AREA A, LEVEL 1, RM A1208	AHU-1	SA	REC / VERT	12	10		0.83	X		1	SEE NOTES
1A-SD-20	AREA A, LEVEL 1, RM A1209	AHU-1	SA	REC / VERT	12	10		0.83	X		1	SEE NOTES
2A-SD-22	AREA A, LEVEL 1, RM A1213	AHU-1	SA	REC / VERT	22	8		1.22	X		1	SEE NOTES
1A-SD-22	AREA A, LEVEL 2, CORR	AHU-2	SA	REC / VERT	14	14		1.36	X		1	SEE NOTES

ACTUATOR SUM = 27  
 NOTES  
 1. DESIGNATION: 1-2-3 : 1=BUILDING LEVEL / AREA ; 2=AD (AUTO DMPR) / SD (SMOKE DMPR) ; 3=DAMPER I.D. NUMBER  
 2. SERVICE : OA=OUTSIDE AIR ; SA=SUPPLY AIR ; RA=RETURN AIR ; RE=RELIEF AIR ; EA=EXHAUST AIR ; TA=TRANSFER AIR  
 3. ALL DAMPER ACTUATORS ARE CURRENTLY PNEUMATIC AND ARE TO BE CHANGED TO ELECTRONIC.

**CONTROL DAMPER SCHEDULE - AREA 'C' (EXISTING)**

DESIG	LOCATION	ASSOC EQUIP	SERVICE	TYPE	DAMPER SIZE (IN)			AREA SQ. FT.	FAIL CLOSED (N.C.)	FAIL OPEN (N.O.)	NUMBER EXIST. ACTUATORS	REMARKS
					BLADE LENGTH	HEIGHT	DIAMETER					
2												

**CONTROL DAMPER SCHEDULE - AREA 'H' (EXISTING)**

DESIG.	LOCATION	ASSOC. EQUIP.	SERVICE	TYPE	DAMPER SIZE (IN.)			AREA SQ. FT.	FAIL CLOSED (N.C.)	FAIL OPEN (N.O.)	NUMBER EXIST. ACTUATORS	REMARKS
					BLADE LENGTH	HEIGHT	DIAMETER					
2HAD-1	AREA H, LEVEL 2, MECH H2002	AHU-16	CA	REC / VERT	24	24		4.00		X	1	SEE NOTES
2HAD-2	AREA H, LEVEL 2, MECH H2002	AHU-16	CA	REC / VERT	24	24		4.00		X	1	SEE NOTES
2HAD-3	AREA H, LEVEL 2, MECH H2002	EF-2H21	OA	REC / VERT	24	48		8.00	X		1	SEE NOTES
2HAD-4	AREA H, LEVEL 2, MECH H2004	AHU-11,17	CA	REC / VERT	24	24		4.00		X	1	SEE NOTES
2HAD-5	AREA H, LEVEL 2, MECH H2004	AHU-11,17	CA	REC / VERT	24	24		4.00		X	1	SEE NOTES
2HAD-6	AREA H, LEVEL 2, MECH H2004	EF-2H28	OA	REC / VERT	24	48		8.00	X		1	SEE NOTES
2HAD-7	AREA H, LEVEL 2, MECH H2004	AHU-11,19	CA	REC / VERT	24	24		4.00		X	1	SEE NOTES
2HAD-8	AREA H, LEVEL 2, MECH H2004	AHU-11,19	CA	REC / VERT	24	24		4.00		X	1	SEE NOTES
2HAD-9	AREA H, LEVEL 2, MECH H2004	EF-2H29	OA	REC / VERT	24	48		8.00	X		1	SEE NOTES
2HAD-10	AREA H, LEVEL 2, MECH H2005	AHU-18	CA	REC / VERT	24	24		4.00		X	1	SEE NOTES
2HAD-11	AREA H, LEVEL 2, MECH H2005	AHU-18	CA	REC / VERT	24	24		4.00		X	1	SEE NOTES
2HAD-12	AREA H, LEVEL 2, MECH H2005	EF-2H30	OA	REC / VERT	24	48		8.00	X		1	SEE NOTES
2HAD-13	AREA H, LEVEL 2, MECH H2002	SF-2H10	OA	REC / VERT	26	34		6.14		X	1	SEE NOTES
2HAD-14	AREA H, LEVEL 1, NE DAY RM	SF-1H9	OA	RND / VERT			24	3.14		X	1	SEE NOTES
2HAD-15	AREA H, LEVEL 2, MECH H2004	AHU-11	RA	REC / HORIZ	84	24		14.00	X		2	SEE NOTES - NO VIS ID
2HAD-16	AREA H, LEVEL 2, MECH H2004	SF-2H18	OA	REC / VERT	40	20		5.56		X	1	SEE NOTES
2HAD-17	AREA H, LEVEL 2, MECH H2004	EF-1H2	EA	REC / VERT	34	24		5.67		X	1	SEE NOTES
2HAD-18	AREA H, LEVEL 2, MECH H2004	SF-2H8	OA	REC / VERT	26	34		6.14		X	1	SEE NOTES
2HAD-19	AREA H, LEVEL 1, SE DAY RM	SF-1H9	OA	RND / VERT			24	3.14		X	1	SEE NOTES
2HAD-20	AREA H, LEVEL 2, MECH H2004	SF-2H7	OA	REC / VERT	26	34		6.14		X	1	SEE NOTES
2HAD-21	AREA H, LEVEL 1, SW DAY RM	SF-1H2	OA	RND / VERT			24	3.14		X	1	SEE NOTES
2HAD-22	AREA H, LEVEL 1, CONTROL RM	SF-1H14	OA	REC / VERT	26	12		2.17		X	1	SEE NOTES
2HAD-23	AREA H, LEVEL 1, NW DAY RM	SF-1H10	OA	RND / VERT			24	3.14		X	1	SEE NOTES
2HAD-24	AREA H, LEVEL 2, NE REC AREA	EF-2H7	EA / RA	REC / VERT	40	20		5.56	X		1	SEE NOTES
2HAD-25	AREA H, LEVEL 2, NE REC AREA	AHU-16	SA	REC / VERT	24	24		4.00		X	1	SEE NOTES
2HAD-26	AREA H, LEVEL 2, NW REC AREA	AHU-18	SA	REC / VERT	16	14		1.56	X		1	SEE NOTES
2HAD-27	AREA H, LEVEL 2, NW REC AREA	AHU-18	SA	REC / VERT	24	12		2.00	X		1	SEE NOTES
2HAD-28	AREA H, LEVEL 2, NE DAY RM	EF-2H7	EA / RA	REC / VERT	40	20		5.56	X		1	SEE NOTES
2HAD-29	AREA H, LEVEL 2, NE DAY RM	EF-2H3	RE	REC / HORIZ	57	57		22.56		X	2	SEE NOTES MOD
2HAD-30	AREA H, LEVEL 2, NE DAY RM	EF-2H7	EA	REC / HORIZ	40	40		11.11		X	1	SEE NOTES
2HAD-31	AREA H, LEVEL 2, NE DAY RM	SF-2H8	OA	RND / HORIZ			24	3.14		X	1	SEE NOTES
2HAD-32	AREA H, LEVEL 2, SE REC AREA	EF-2H6	EA / RA	REC / VERT	40	20		5.56	X		1	SEE NOTES
2HAD-33	AREA H, LEVEL 2, SE REC AREA	AHU-17	SA	REC / HORIZ	24	24		4.00		X	1	SEE NOTES
2HAD-34	AREA H, LEVEL 2, SE DAY RM	EF-2H6	EA / RA	REC / VERT	40	20		5.56	X		1	SEE NOTES
2HAD-35	AREA H, LEVEL 2, SE DAY RM	EF-2H2	RE	REC / HORIZ	57	57		22.56		X	2	SEE NOTES MOD
2HAD-36	AREA H, LEVEL 2, SE DAY RM	EF-2H6	EA	REC / HORIZ	40	40		11.11		X	1	SEE NOTES
2HAD-37	AREA H, LEVEL 2, SE DAY RM	SF-2H12	OA	RND / HORIZ			24	3.14		X	1	SEE NOTES
2HAD-38	AREA H, LEVEL 2, SW REC AREA	EF-2H5	EA / RA	REC / VERT	40	20		5.56	X		1	SEE NOTES
2HAD-39	AREA H, LEVEL 2, SW REC AREA	AHU-19	SA	REC / HORIZ	24	24		4.00		X	1	SEE NOTES
2HAD-40	AREA H, LEVEL 2, SW DAY RM	EF-2H5	EA / RA	REC / VERT	40	20		5.56	X		1	SEE NOTES
2HAD-41	AREA H, LEVEL 2, SW DAY RM	EF-2H1	RE	REC / HORIZ	57	57		22.56		X	2	SEE NOTES MOD
2HAD-42	AREA H, LEVEL 2, SW DAY RM	EF-2H5	EA	REC / HORIZ	40	40		11.11		X	1	SEE NOTES
2HAD-43	AREA H, LEVEL 2, SW DAY RM	SF-2H11	OA	RND / HORIZ			24	3.14		X	1	SEE NOTES
2HAD-44	AREA H, LEVEL 2, NW REC AREA	AHU-18	SA	REC / VERT	16	12		1.33	X		1	SEE NOTES
2HAD-45	AREA H, LEVEL 2, NW REC AREA	AHU-18	SA	REC / HORIZ	24	24		4.00		X	1	SEE NOTES
2HAD-46	AREA H, LEVEL 2, NW DAY RM	EF-2H8	EA / RA	REC / VERT	40	20		5.56	X		1	SEE NOTES
2HAD-47	AREA H, LEVEL 2, NNW DAY RM	EF-2H11	RE	REC / HORIZ	57	57		22.56		X	2	SEE NOTES MOD
2HAD-48	AREA H, LEVEL 2, NNW DAY RM	EF-2H6	EA	REC / HORIZ	40	40		11.11		X	1	SEE NOTES
2HAD-49	AREA H, LEVEL 2, NW DAY RM	SF-2H14	OA	RND / HORIZ			24	3.14		X	1	SEE NOTES
1HAD-50	AREA H, LEVEL 1, CORE AREA	EF-1H2	EA	REC / HORIZ	22	22		3.36		X	1	SEE NOTES
1HAD-51	AREA H, LEVEL 1, CORE AREA	EF-1H2	EA	REC / HORIZ	14	14		1.36		X	1	SEE NOTES
1HAD-52	AREA H, LEVEL 1, CORE AREA	EF-1H2	EA	REC / HORIZ	14	14		1.36		X	1	SEE NOTES
1HAD-53	AREA H, LEVEL 1, CORE AREA	EF-1H2	EA	REC / VERT	18	12		1.50		X	1	SEE NOTES
1HAD-54	AREA H, LEVEL 1, CORE AREA	EF-1H2	EA	REC / VERT	24	8		1.33		X	1	SEE NOTES
1HAD-55	AREA H, LEVEL 1, CORE AREA	EF-1H2	EA	REC / VERT	22	12		1.83		X	1	SEE NOTES
1HAD-56	AREA H, LEVEL 1, CORE AREA	EF-1H2	EA	REC / VERT	20	6		0.83		X	1	SEE NOTES
1HAD-57	AREA H, LEVEL 1, CORE AREA	EF-1H2	EA	REC / VERT	22	12		1.83		X	1	SEE NOTES
1HAD-58	AREA H, LEVEL 1, NE DAY RM	SF-1H8	OA	RND / VERT			24	3.14		X	1	SEE NOTES
1HAD-59	AREA H, LEVEL 1, NE DAY RM	SF-1H8	OA	RND / VERT			6	0.20	X		1	SEE NOTES
1HAD-60	AREA H, LEVEL 1, NE DAY RM	SF-1H7	OA	RND / VERT			24	3.14		X	1	SEE NOTES
1HAD-61	AREA H, LEVEL 1, NE DAY RM	SF-1H7	OA	RND / VERT			6	0.20	X		1	SEE NOTES
1HAD-62	AREA H, LEVEL 1, SE DAY RM	SF-1H6	OA	RND / VERT			24	3.14		X	1	SEE NOTES
1HAD-63	AREA H, LEVEL 1, SE DAY RM	SF-1H8	OA	RND / VERT			6	0.20	X		1	SEE NOTES
1HAD-64	AREA H, LEVEL 1, SE DAY RM	SF-1H4	OA	REC / VERT			27	5.06		X	1	SEE NOTES
1HAD-65	AREA H, LEVEL 1, SE DAY RM	SF-1H4	OA	RND / VERT			6	0.20	X		1	SEE NOTES
1HAD-66	AREA H, LEVEL 1, SW DAY RM	SF-1H8	OA	REC / VERT			27	5.06		X	1	SEE NOTES
1HAD-67	AREA H, LEVEL 1, SW DAY RM	SF-1H8	OA	RND / VERT			6	0.20	X		1	SEE NOTES
1HAD-68	AREA H, LEVEL 1, SW DAY RM	SF-1H1	OA	RND / VERT			24	3.14		X	1	SEE NOTES
1HAD-69	AREA H, LEVEL 1, SW DAY RM	SF-1H1	OA	RND / VERT			6	0.20	X		1	SEE NOTES
1HAD-70	AREA H, LEVEL 1, NW DAY RM	SF-1H11	OA	RND / VERT			24	3.14		X	1	SEE NOTES
1HAD-71	AREA H, LEVEL 1, NW DAY RM	SF-1H11	OA	RND / VERT			6	0.20	X		1	SEE NOTES
1HAD-72	AREA H, LEVEL 1, NW DAY RM	SF-1H12	OA	REC / HORIZ			24	3.14		X	1	SEE NOTES
1HAD-73	AREA H, LEVEL 1, NW DAY RM	SF-1H3	OA	REC / VERT			20	3.32		X	1	SEE NOTES
1HAD-74	AREA H, LEVEL 1, CORE AREA	SF-2H18	OA	REC / VERT			22	8		X	1	SEE NOTES
1HAD-75	AREA H, LEVEL 2, WNW DAY RM	EF-2H12	RE	REC / HORIZ			57	22.56		X	2	SEE NOTES MOD
1HAD-76	AREA H, LEVEL 2, WNW DAY RM	EF-2H27	EA	REC / HORIZ			40	11.11		X	1	SEE NOTES
1HAD-77	AREA H, LEVEL 2, NW CONTROL R	AHU-18	SA	RND / VERT			8	0.35	X		1	SEE NOTES
2HAD-78	AREA H, LEVEL 2, MECH H2002	AHU-11	RA	REC / HORIZ			26	14		X	1	SEE NOTES
2HAD-79	AREA H, LEVEL 2, MECH H2002	AHU-16	RA	REC / VERT			40	28		X	1	SEE NOTES
2HAD-80	AREA H, LEVEL 2, MECH H2004	AHU-11	RA	REC / HORIZ			84	24		X	2	SEE NOTES - NO VIS ID
2HAD-81	AREA H, LEVEL 2, MECH H2004	AHU-17	RA	REC / VERT			40	28		X	1	SEE NOTES
2HAD-82	AREA H, LEVEL 2, MECH H2004	AHU-19	RA	REC / VERT			40	28		X	1	SEE NOTES
2HAD-83	AREA H, LEVEL 2, MECH H2005	AHU-18	RA	REC / VERT			40	28		X	1	SEE NOTES
2HAD-84	AREA H, LEVEL 2, MECH H2004	EF-1H1	EA	REC / HORIZ			24	20		X	1	SEE NOTES - NO VIS ID
2HAD-85	AREA H, LEVEL 2, MECH H2004	EF-1H2	EA	REC / HORIZ			34	24		X	1	SEE NOTES - NO VIS ID
2HAD-86	AREA H, LEVEL 2, MECH H2004	SF-2H18	SA	REC / HORIZ			40	20		X	1	SEE NOTES - NO VIS ID

ACTUATOR SUM = 83

NOTES  
 1. DESIGNATION: 1-33 : 1=BUILDING LEVEL / AREA : 2=AD (AUTO DMPR) / SD (SMOKE DMPR) : 3=DAMPER I.D. NUMBER  
 2. SERVICE: OA=OUTSIDE AIR : SA=SUPPLY AIR : RA=RETURN AIR : RE=RELIEF AIR : EA=EXHAUST AIR : TA=TRANSFER AIR  
 3. ALL DAMPER ACTUATORS ARE CURRENTLY PNEUMATIC AND ARE TO BE CHANGED TO ELECTRONIC.

**CONTROL DAMPER SCHEDULE - AREA 'G' (EXISTING)**

DESIG.	LOCATION	ASSOC. EQUIP.	SERVICE	TYPE	DAMPER SIZE (IN.)			AREA SQ. FT.	FAIL CLOSED (N.C.)	FAIL OPEN (N.O.)	NUMBER EXIST. ACTUATORS	REMARKS
					BLADE LENGTH	HEIGHT	DIAMETER					
2G-AD-1	AREA G, LEVEL 2, MECH G2002	AHU-12	CA	REC / VERT	24	24		4.00		X	1	SEE NOTES
2G-AD-2	AREA G, LEVEL 2, MECH G2002	AHU-12	CA	REC / VERT	24	24		4.00		X	1	SEE NOTES
2G-AD-3	AREA G, LEVEL 2, MECH G2002	EF-2G28	OA	REC / VERT	24	48		8.00	X		1	SEE NOTES
2G-AD-4	AREA G, LEVEL 2, MECH G2004	AHU-10,13	CA	REC / VERT	24	24		4.00		X	1	SEE NOTES
2G-AD-5	AREA G, LEVEL 2, MECH G2004	AHU-10,13	CA	REC / VERT	24	24		4.00		X	1	SEE NOTES
2G-AD-6	AREA G, LEVEL 2, MECH G2004	EF-2G27	OA	REC / VERT	24	48		8.00	X		1	SEE NOTES
2G-AD-7	AREA G, LEVEL 2, MECH G2004	AHU-10,15	CA	REC / VERT	24	24		4.00		X	1	SEE NOTES
2G-AD-8	AREA G, LEVEL 2, MECH G2004	AHU-10,15	CA	REC / VERT	24	24		4.00		X	1	SEE NOTES
2G-AD-9	AREA G, LEVEL 2, MECH G2004	EF-2G28	OA	REC / VERT	24	48		8.00	X		1	SEE NOTES
2G-AD-10	AREA G, LEVEL 2, MECH G2005	AHU-14	CA	REC / VERT	24	24		4.00		X	1	SEE NOTES
2G-AD-11	AREA G, LEVEL 2, MECH G2005	AHU-14	CA	REC / VERT	24	24		4.00		X	1	SEE NOTES
2G-AD-12	AREA G, LEVEL 2, MECH G2005	EF-2G29	OA	REC / VERT	24	48		8.00	X		1	SEE NOTES
2G-AD-13	AREA G, LEVEL 2, MECH G2002	SF-2G10	OA	REC / VERT	26	34		6.14		X	1	SEE NOTES
2G-AD-14	AREA G, LEVEL 1, NE DAY RM	SF-1G9	OA	RND / VERT			24	3.14		X	1	SEE NOTES
2G-AD-15	AREA G, LEVEL 2, MECH G2004	AHU-10	RA	REC / HORIZ	84	24		14.00	X		2	SEE NOTES - NO VIS ID
2G-AD-16	AREA G, LEVEL 2, MECH G2004	SF-2G18	OA	REC / VERT	40	20		5.56		X	1	SEE NOTES
2G-AD-17	AREA G, LEVEL 2, MECH G2004	EF-1G2	EA	REC / VERT	34	24		5.67		X	1	SEE NOTES
2G-AD-18	AREA G, LEVEL 2, MECH G2004	SF-2G8	OA	REC / VERT	26	34		6.14		X	1	SEE NOTES
2G-AD-19	AREA G, LEVEL 1, SE DAY RM	SF-1G9	OA	RND / VERT			24	3.14		X	1	SEE NOTES
2G-AD-20	AREA G, LEVEL 2, MECH G2004	SF-2G7	OA	REC / VERT	26	34		6.14		X	1	SEE NOTES
2G-AD-21	AREA G, LEVEL 1, SW DAY RM	SF-1G2	OA	RND / VERT			24	3.14		X	1	SEE NOTES
2G-AD-22	AREA G, LEVEL 2, MECH G2005	SF-2G10	OA	REC / VERT	26	34		6.14		X	1	SEE NOTES
2G-AD-23	AREA G, LEVEL 1, NW DAY RM	SF-1G9	OA	RND / VERT			24	3.14		X	1	SEE NOTES
2G-AD-24	AREA G, LEVEL 2, NE REC AREA	SF-2G15	OA	REC / VERT	20	20		2.78		X	1	SEE NOTES
2G-AD-25	NOT USED							0.00			</	

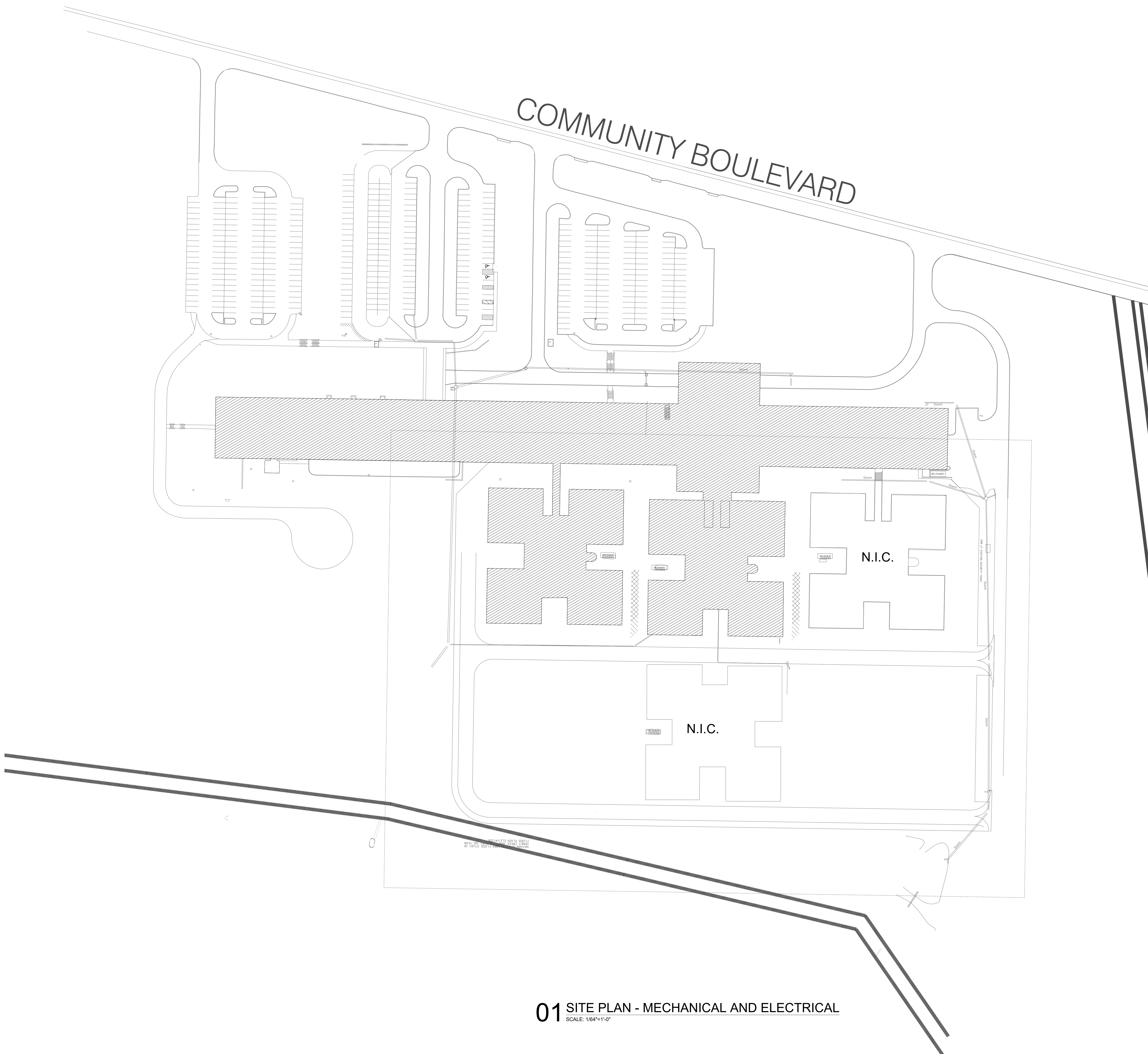

**GENERAL NOTES**

1. REFER TO MP0.0 FOR GENERAL MECHANICAL NOTES, ABBREVIATIONS AND SYMBOLS.

**01 SITE PLAN - MECHANICAL AND ELECTRICAL**  
SCALE: 1/8"=1'-0"

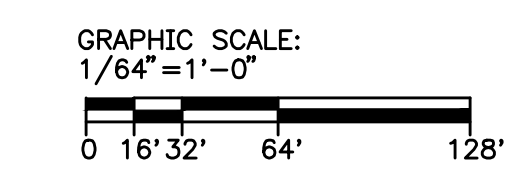
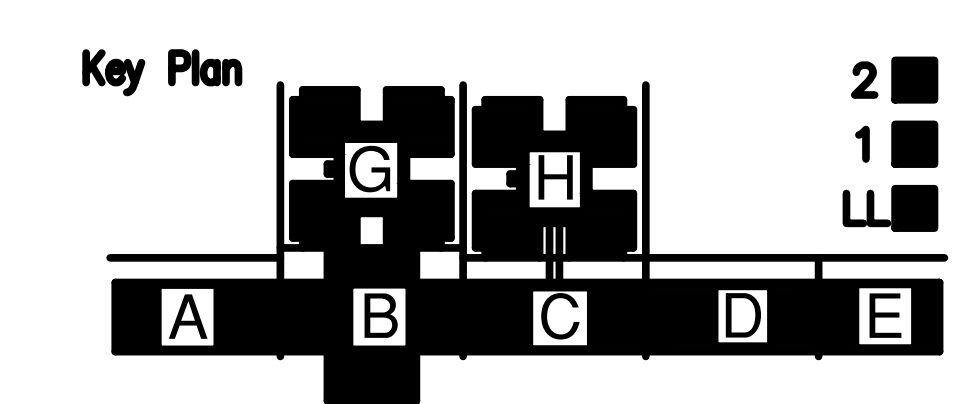

Texas Registered Firm No. F-7489  
500 North Central Expressway, Suite 310  
Frisco, TX 75034  
Phone: 972.261.4670  
Fax: 972.261.4671  
Email: mjb@mdeng.com  
Project Number: 17939

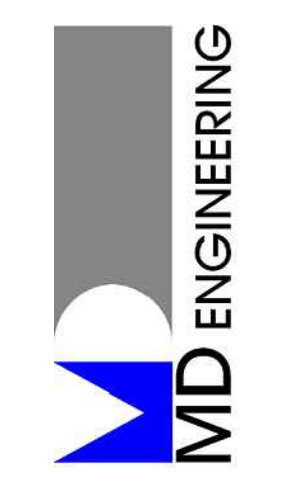

**Collin County Justice Center**  
Upgrade Pneumatic to Electronic Actuators  
4300 Community Ave. McKinney, Texas 75071

Revisions:	DATE	DESCRIPTION



MECHANICAL AND ELECTRICAL SITE PLAN

Project No.  
**17939**

Sheet No.  
**ME1.0**

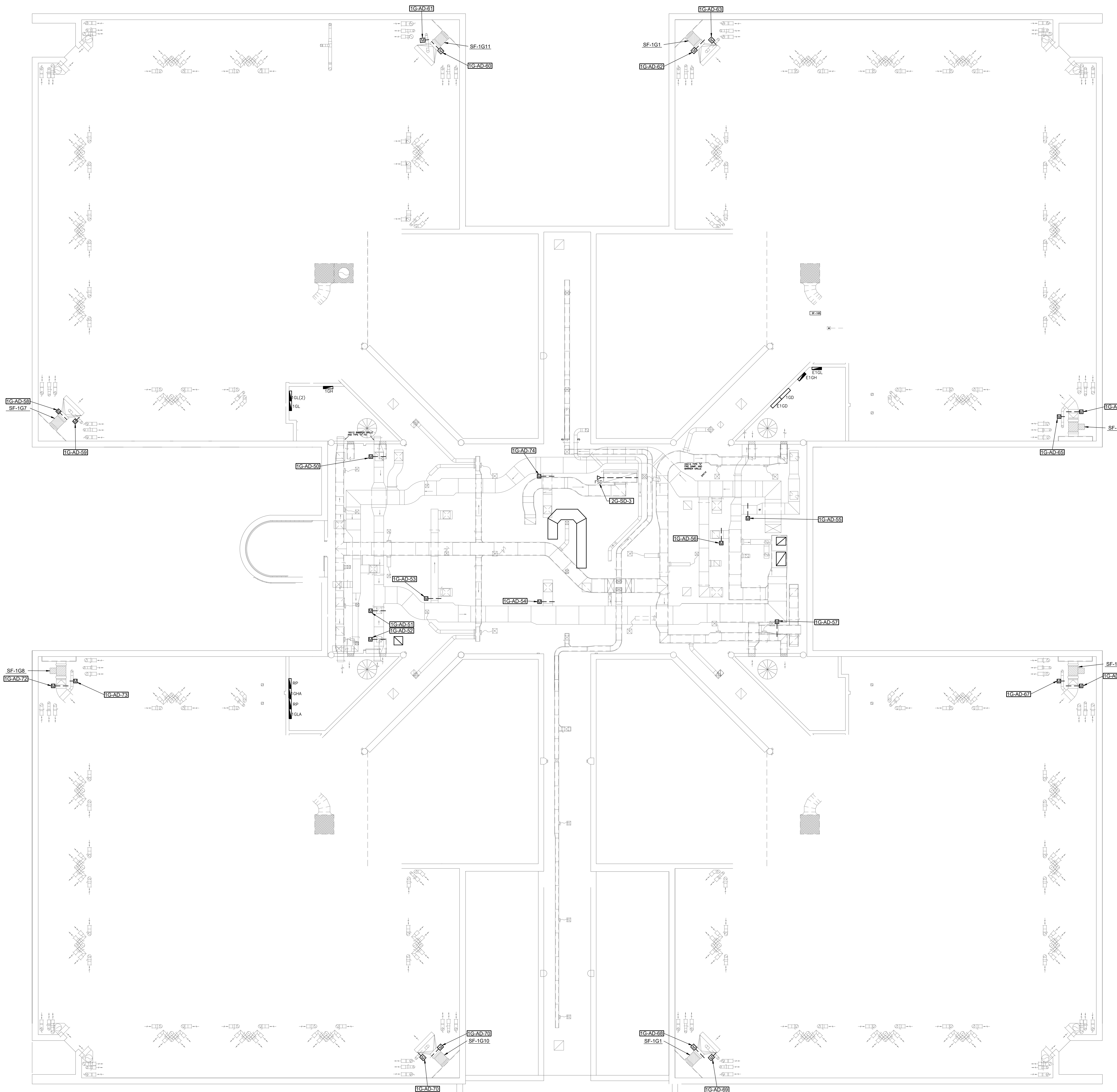

**GENERAL NOTES**

- ALL EXISTING DAMPER ACTUATORS ARE CURRENTLY PNEUMATIC AND SHALL BE CHANGED TO ELECTRONIC.
- SEE PLAN SHEETS M0.0 & E0.0 FOR NOTES, SYMBOLS, AND ABBREVIATIONS. REFER TO SPECIFICATIONS FOR ADDITIONAL PROJECT REQUIREMENTS.
- REFER TO DIVISION 15 (23) BOOK SPECIFICATIONS FOR HVAC SPECIFICATIONS AND TO DIVISION 26 ELECTRICAL SPECIFICATIONS.
- NEW ELECTRONIC ACTUATORS WILL REQUIRE 24V AT THE ACTUATORS AND 120V AT THE HEAD-END EQUIPMENT. THE ELECTRICAL CONTRACTOR SHALL BE RESPONSIBLE FOR VOLTAGE REQUIREMENTS AND CONNECTIONS TO BE MADE. COORDINATE WITH THE MECHANICAL CONTRACTOR FOR EXACT LOCATIONS OF BOTH 24V AND 120V POWER LOCATIONS.
- VOLTAGE SHALL BE EMERGENCY BACKUP POWER ONLY. PULL ALL CIRCUITS FROM PANELBOARDS ON THE EMERGENCY GENERATOR. UTILIZE ALL SPARE 20A 1P CIRCUIT BREAKERS FROM EMERGENCY PANELS. AS REQUIRED PROVIDE A 20AMP 1P CIRCUIT BREAKER IN SPACES. PLACE NO MORE THAN 1600WATTS PER 20A 120V CIRCUIT. PROVIDE A TYPED UPDATED PANEL SCHEDULE FOR ALL PANEL BOARDS WITH NEW CIRCUIT DESIGNATIONS.
- PROVIDE ACOUSTIC SEAL AT ALL ACOUSTIC WALLS TO DECK PENETRATIONS.
- CONTRACT DRAWING ARE DIAGRAMMATIC. CONTRACTOR SHALL INSTALL ALL MECHANICAL ACTUATORS & ASSOCIATED MATERIALS IN ACCORDANCE WITH THE LATEST SMACNA STANDARDS.
- COORDINATE WITH ALL TRADES BEFORE INSTALLING ANY NEW EQUIPMENT OR APPURTENANCES.

**01 FIRST FLOOR OVERALL PLAN - BUILDING G**  
SCALE: 1/8"=1'-0"

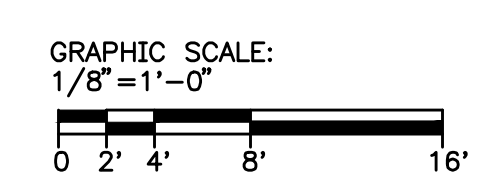
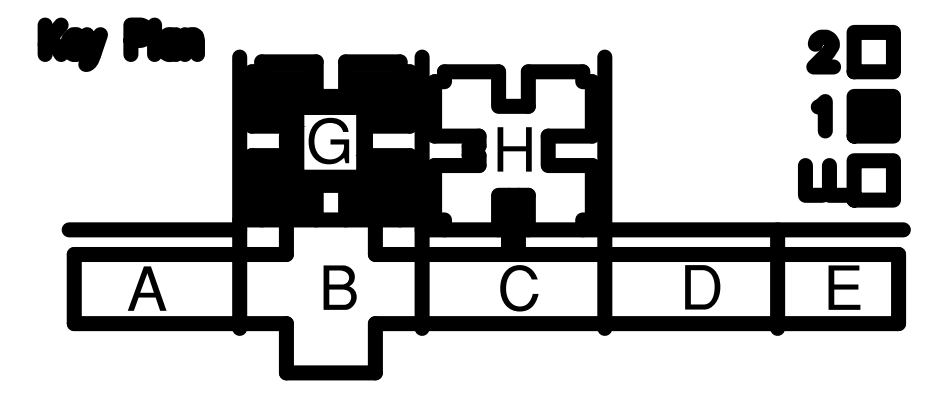

Texas Registered Firm No. F-7489  
500 North Central Expressway, Suite 310  
Ft. Worth, TX 76104  
Phone: 817.467.0200  
Fax: 817.467.0200  
Email: mjb@mdeng.com  
Project Number: 17939

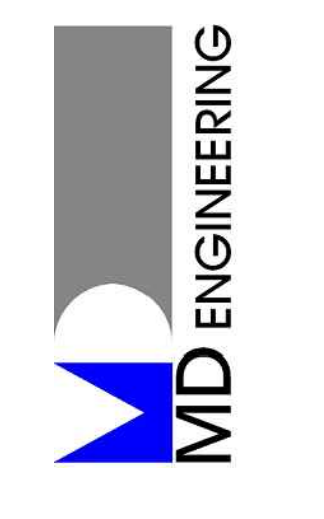

**Collin County Justice Center**  
Upgrade Pneumatic to Electronic Actuators  
4300 Community Ave. McKinney, Texas 75071

Revisions:	DATE	DESCRIPTION



FIRST FLOOR  
OVERALL PLAN  
- BUILDING G

Project No.  
**17939**

Sheet No.  
**ME1.1**

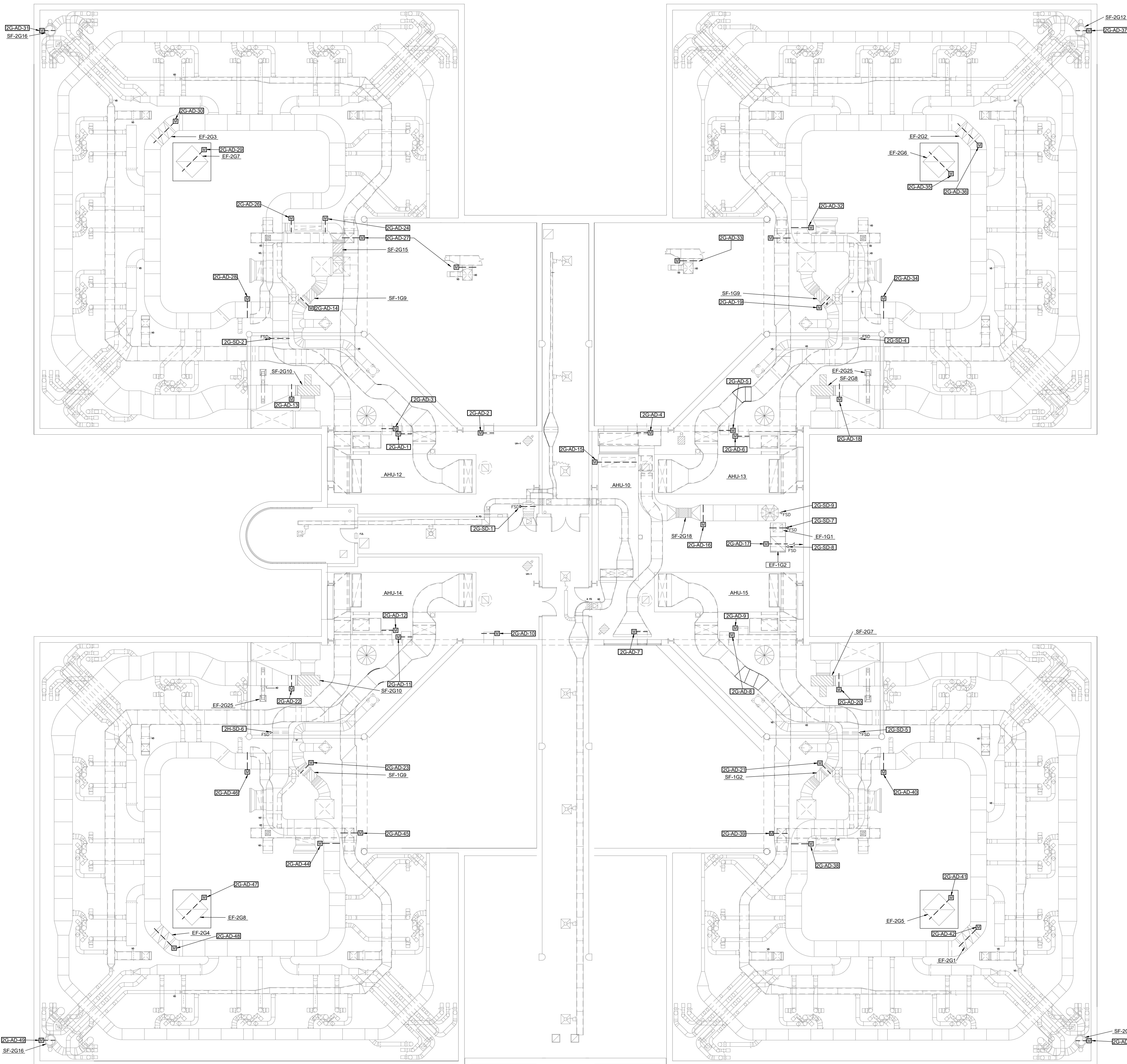

**GENERAL NOTES**

1. ALL EXISTING DAMPER ACTUATORS ARE CURRENTLY PNEUMATIC AND SHALL BE CHANGED TO ELECTRONIC.
2. SEE PLAN SHEETS M0.0 & E0.0 FOR NOTES, SYMBOLS, AND ABBREVIATIONS. REFER TO SPECIFICATIONS FOR ADDITIONAL PROJECT REQUIREMENTS.
3. REFER TO DIVISION 15 (23) BOOK SPECIFICATIONS FOR HVAC SPECIFICATIONS AND TO DIVISION 26 ELECTRICAL SPECIFICATIONS.
4. NEW ELECTRONIC ACTUATORS WILL REQUIRE 24V AT THE ACTUATORS AND 120V AT THE HEAD-END EQUIPMENT. THE ELECTRICAL CONTRACTOR SHALL BE RESPONSIBLE FOR VOLTAGE REQUIREMENTS AND CONNECTIONS TO BE MADE. COORDINATE WITH THE MECHANICAL CONTRACTOR FOR EXACT LOCATIONS OF BOTH 24V AND 120V POWER LOCATIONS.
5. VOLTAGE SHALL BE EMERGENCY BACKUP POWER ONLY. PULL ALL CIRCUITS FROM PANELBOARDS ON THE EMERGENCY GENERATOR. UTILIZE ALL SPARE 20A 1P CIRCUIT BREAKERS FROM EMERGENCY PANELS. AS REQUIRED PROVIDE A 20AMP 1P CIRCUIT BREAKER IN SPACES. PLACE NO MORE THAN 1600WATTS PER 20A 120V CIRCUIT. PROVIDE A TYPED UPDATED PANEL SCHEDULE FOR ALL PANEL BOARDS WITH NEW CIRCUIT DESIGNATIONS.
6. PROVIDE ACOUSTIC SEAL AT ALL ACOUSTIC WALLS TO DECK PENETRATIONS.
7. CONTRACT DRAWING ARE DIAGRAMMATIC. CONTRACTOR SHALL INSTALL ALL MECHANICAL ACTUATORS & ASSOCIATED MATERIALS IN ACCORDANCE WITH THE LATEST SMACNA STANDARDS.
8. COORDINATE WITH ALL TRADES BEFORE INSTALLING ANY NEW EQUIPMENT OR APPURTENANCES.

Texas Registered Firm No. F-7489  
 500 North Central Expressway, Suite 310  
 Irving, TX 75038  
 Email: mlabrecq@mdeng.com  
 Project Number: 17939

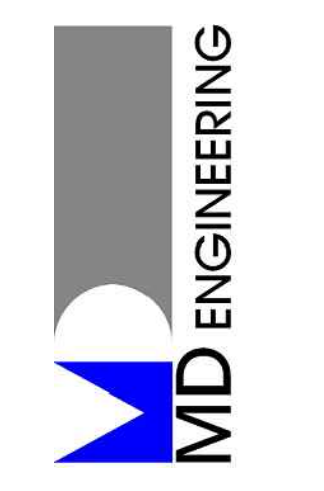

**Collin County Justice Center**  
 Upgrade Pneumatic to Electronic Actuators  
 4300 Community Ave. McKinney, Texas 75071

Revisions:	DATE	DESCRIPTION



SECOND FLOOR  
 OVERALL PLAN  
 - BUILDING G

Project No.  
**17939**

Sheet No.  
**ME1.2**

**01 SECOND FLOOR OVERALL PLAN - BUILDING G**  
 SCALE: 1/8"=1'-0"

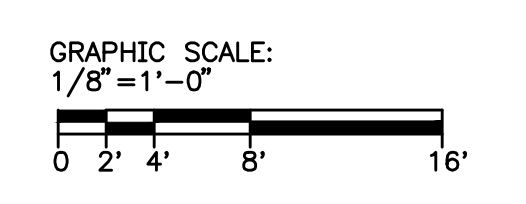
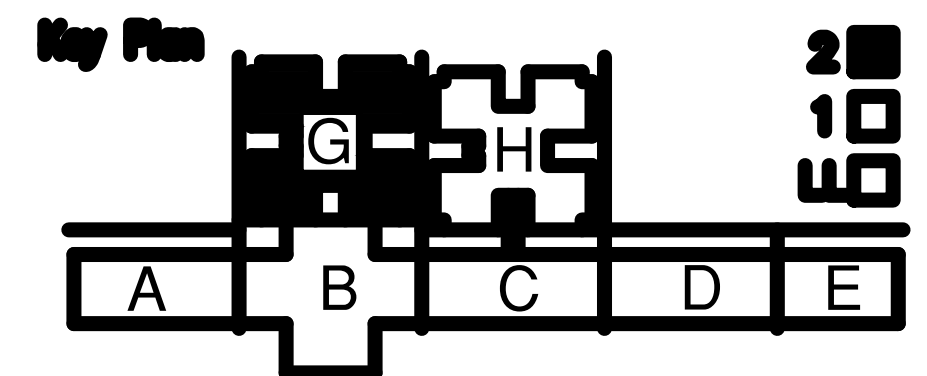



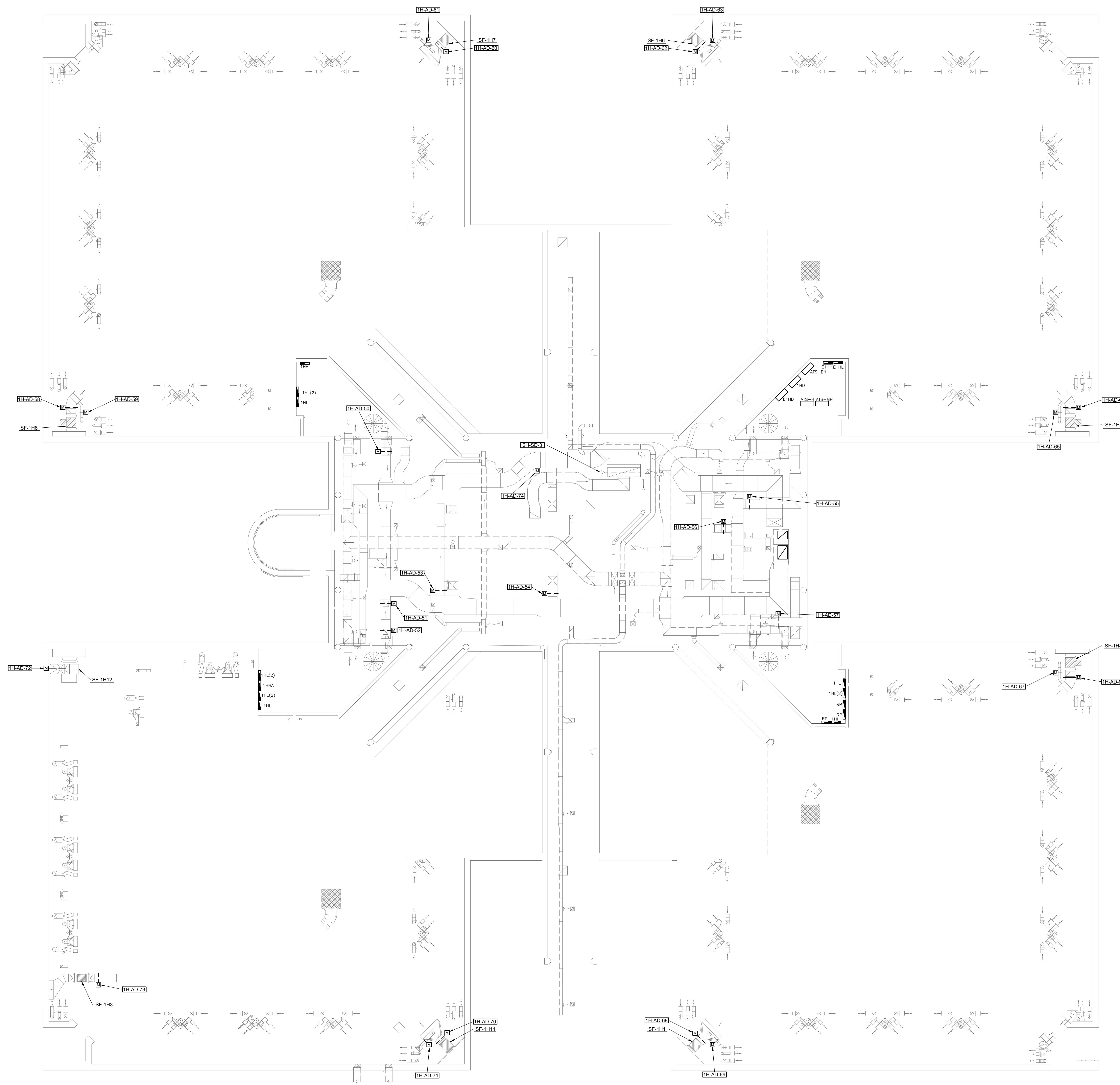

**GENERAL NOTES**

- ALL EXISTING DAMPER ACTUATORS ARE CURRENTLY PNEUMATIC AND SHALL BE CHANGED TO ELECTRONIC.
- SEE PLAN SHEETS M0.0 & E0.0 FOR NOTES, SYMBOLS, AND ABBREVIATIONS. REFER TO SPECIFICATIONS FOR ADDITIONAL PROJECT REQUIREMENTS.
- REFER TO DIVISION 15 (23) BOOK SPECIFICATIONS FOR HVAC SPECIFICATIONS AND TO DIVISION 26 ELECTRICAL SPECIFICATIONS.
- NEW ELECTRONIC ACTUATORS WILL REQUIRE 24V AT THE ACTUATORS AND 120V AT THE HEAD-END EQUIPMENT. THE ELECTRICAL CONTRACTOR SHALL BE RESPONSIBLE FOR VOLTAGE REQUIREMENTS AND CONNECTIONS TO BE MADE. COORDINATE WITH THE MECHANICAL CONTRACTOR FOR EXACT LOCATIONS OF BOTH 24V AND 120V POWER LOCATIONS.
- VOLTAGE SHALL BE EMERGENCY BACKUP POWER ONLY. PULL ALL CIRCUITS FROM PANELBOARDS ON THE EMERGENCY GENERATOR. UTILIZE ALL SPARE 20A 1P CIRCUIT BREAKERS FROM EMERGENCY PANELS AS REQUIRED PROVIDE A 20AMP 1P CIRCUIT BREAKER IN SPACES. PLACE NO MORE THAN 1600WATTS PER 20A 120V CIRCUIT. PROVIDE A TYPED UPDATED PANEL SCHEDULE FOR ALL PANEL BOARDS WITH NEW CIRCUIT DESIGNATIONS.
- PROVIDE ACOUSTIC SEAL AT ALL ACOUSTIC WALLS TO DECK PENETRATIONS.
- CONTRACT DRAWING ARE DIAGRAMMATIC. CONTRACTOR SHALL INSTALL ALL MECHANICAL ACTUATORS & ASSOCIATED MATERIALS IN ACCORDANCE WITH THE LATEST SMAGNA STANDARDS.
- COORDINATE WITH ALL TRADES BEFORE INSTALLING ANY NEW EQUIPMENT OR APPURTENANCES.

**01 FIRST FLOOR OVERALL PLAN - BUILDING H**  
SCALE: 1/8"=1'-0"

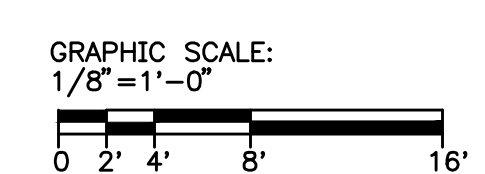
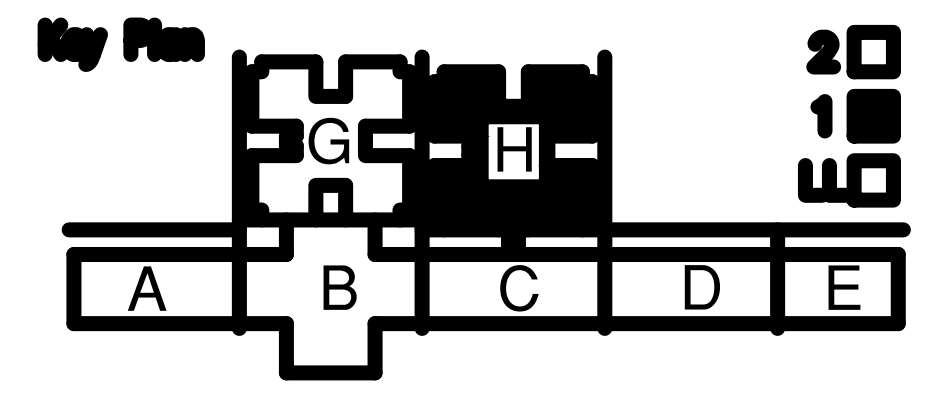

Texas Registered Firm No. F-7489  
500 North Central Expressway, Suite 310  
Frisco, TX 75034  
Email: mjb@mdeng.com  
Project Number: 17939

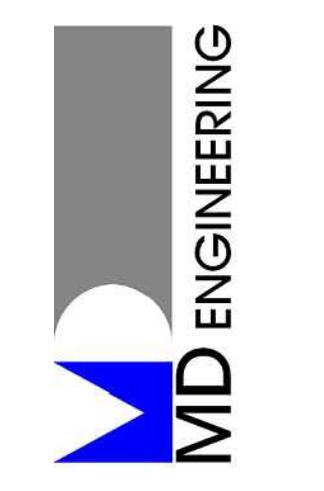

**Collin County Justice Center**  
Upgrade Pneumatic to Electronic Actuators  
4300 Community Ave. McKinney, Texas 75071

Revisions:	DATE	DESCRIPTION



FIRST FLOOR  
OVERALL PLAN  
- BUILDING H

Project No.  
**17939**

Sheet No.  
**ME1.3**

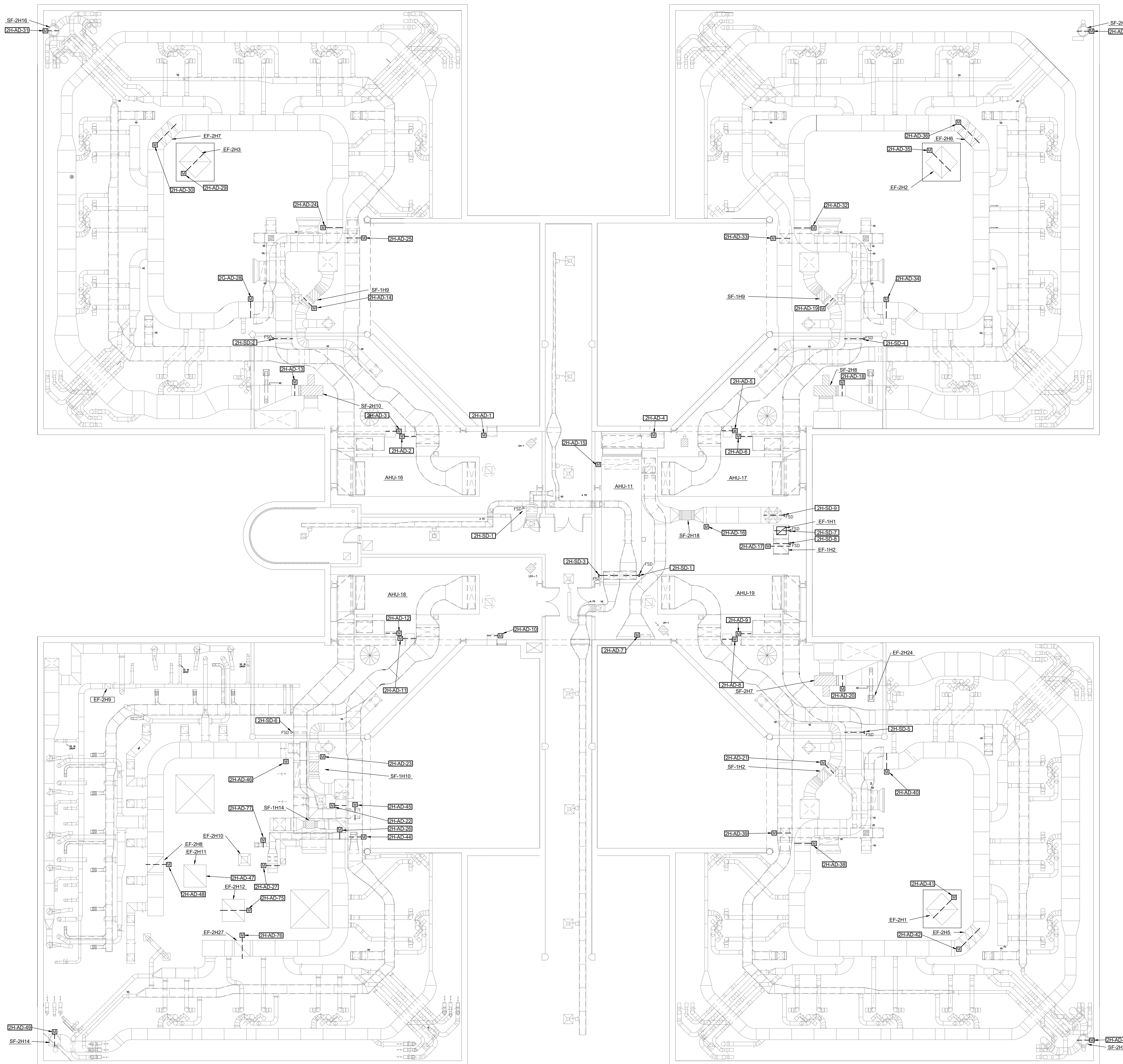

**GENERAL NOTES**

1. ALL EXISTING DAMPER ACTUATORS ARE CURRENTLY PNEUMATIC AND SHALL BE CHANGED TO ELECTRONIC.
2. SEE PLAN SHEETS M0.0 & E0.0 FOR NOTES, SYMBOLS, AND ABBREVIATIONS. REFER TO SPECIFICATIONS FOR ADDITIONAL PROJECT REQUIREMENTS.
3. REFER TO DIVISION 15 (23) BOOK SPECIFICATIONS FOR HVAC SPECIFICATIONS AND TO DIVISION 26 ELECTRICAL SPECIFICATIONS.
4. NEW ELECTRONIC ACTUATORS WILL REQUIRE 24V AT THE ACTUATORS AND 120V AT THE HEAD-END EQUIPMENT. THE ELECTRICAL CONTRACTOR SHALL BE RESPONSIBLE FOR VOLTAGE REQUIREMENTS AND CONNECTIONS TO BE MADE. COORDINATE WITH THE MECHANICAL CONTRACTOR FOR EXACT LOCATIONS OF BOTH 24V AND 120V POWER LOCATIONS.
5. VOLTAGE SHALL BE EMERGENCY BACKUP POWER ONLY. PULL ALL CIRCUITS FROM PANELBOARDS ON THE EMERGENCY GENERATOR. UTILIZE ALL SPARE 20A 1P CIRCUIT BREAKERS FROM EMERGENCY PANELS. AS REQUIRED PROVIDE A 20AMP 1P CIRCUIT BREAKER IN SPACES. PLACE NO MORE THAN 1600WATTS PER 20A 120V CIRCUIT. PROVIDE A TYPED UPDATED PANEL SCHEDULE FOR ALL PANEL BOARDS WITH NEW CIRCUIT DESIGNATIONS.
6. PROVIDE ACOUSTIC SEAL AT ALL ACOUSTIC WALLS TO DECK PENETRATIONS.
7. CONTRACT DRAWING ARE DIAGRAMMATIC. CONTRACTOR SHALL INSTALL ALL MECHANICAL ACTUATORS & ASSOCIATED MATERIALS IN ACCORDANCE WITH THE LATEST SMACNA STANDARDS.
8. COORDINATE WITH ALL TRADES BEFORE INSTALLING ANY NEW EQUIPMENT OR APPURTENANCES.

Texas Registered Firm No. F-7489  
 500 North Central Expressway, Suite 310  
 Irving, TX 75038-4677  
 Email: mlabarca@mdeng.com  
 Project Number: 17939

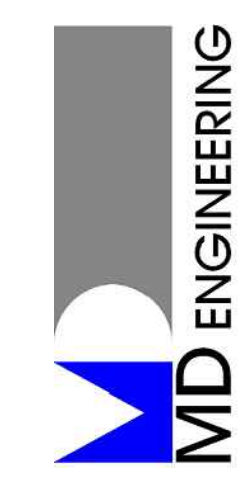

**Collin County Justice Center**  
 Upgrade Pneumatic to Electronic Actuators  
 4300 Community Ave. McKinney, Texas 75071

Revisions:	DATE	DESCRIPTION



SECOND FLOOR  
 OVERALL PLAN  
 - BUILDING H

Project No.  
**17939**

Sheet No.  
**ME1.4**

**01 SECOND FLOOR OVERALL PLAN - BUILDING H**  
 SCALE: 1/8"=1'-0"

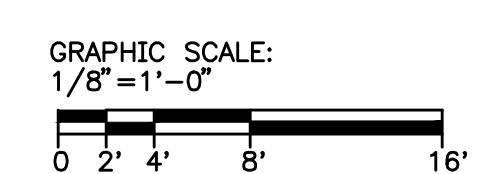
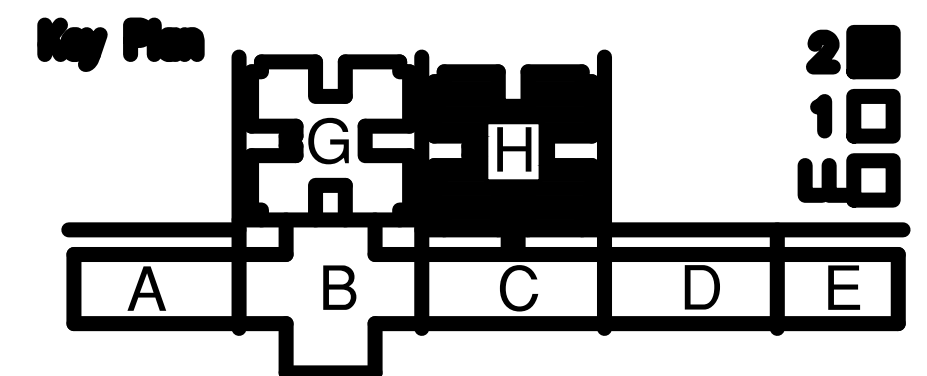

Texas Registered Firm No. F-7489  
 500 North Central Expressway, Suite 310  
 Irving, Texas 75038  
 Phone: 972.467.0000  
 Fax: 972.467.0000  
 Email: mcb@mdeng.com  
 Project Number: 17939

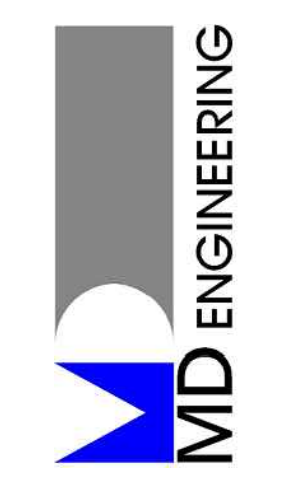

Collin County Justice Center  
 Upgrade Pneumatic to Electronic Actuators  
 4300 Community Ave. McKinney, Texas 75071

Revisions:	DATE	DESCRIPTION



OVERALL PLAN  
 BUILDING 19

Project No.  
**17939**

Sheet No.  
**ME1.5**

**GENERAL NOTES**

- ALL EXISTING DAMPER ACTUATORS ARE CURRENTLY PNEUMATIC AND SHALL BE CHANGED TO ELECTRONIC.
- SEE PLAN SHEETS MD.0 & ED.0 FOR NOTES, SYMBOLS, AND ABBREVIATIONS. REFER TO SPECIFICATIONS FOR ADDITIONAL PROJECT REQUIREMENTS.
- REFER TO MS1.1 (OR DIVISION 15 (23) BOOK SPECIFICATIONS) FOR HVAC SPECIFICATIONS. REFER TO DIVISION 26 ELECTRICAL SPECIFICATIONS.
- NEW ELECTRONIC ACTUATORS WILL REQUIRE 24V AT THE ACTUATORS AND 120V AT THE HEAD-END EQUIPMENT. THE ELECTRICAL CONTRACTOR SHALL BE RESPONSIBLE FOR VOLTAGE REQUIREMENTS AND CONNECTIONS TO BE MADE. COORDINATE WITH THE MECHANICAL CONTRACTOR FOR EXACT LOCATIONS OF BOTH 24V AND 120V POWER LOCATIONS.
- VOLTAGE SHALL BE EMERGENCY BACKUP POWER ONLY. PULL ALL CIRCUITS FROM PANELBOARDS ON THE EMERGENCY GENERATOR. UTILIZE ALL SPARE 20A 1P CIRCUIT BREAKERS FROM EMERGENCY PANELS. AS REQUIRED PROVIDE A 20AMP 1P CIRCUIT BREAKER IN SPACES. PLACE NO MORE THAN 1600WATTS PER 20A 120V CIRCUIT. PROVIDE A TYPED UPDATED PANEL SCHEDULE FOR ALL PANEL BOARDS WITH NEW CIRCUIT DESIGNATIONS.
- PROVIDE ACOUSTIC SEAL AT ALL ACOUSTIC WALLS TO DECK PENETRATIONS.
- CONTRACT DRAWING ARE DIAGRAMMATIC. CONTRACTOR SHALL INSTALL ALL MECHANICAL ACTUATORS & ASSOCIATED MATERIALS IN ACCORDANCE WITH THE LATEST SMACNA STANDARDS.
- COORDINATE WITH ALL TRADES BEFORE INSTALLING ANY NEW EQUIPMENT OR APPURTENANCES.

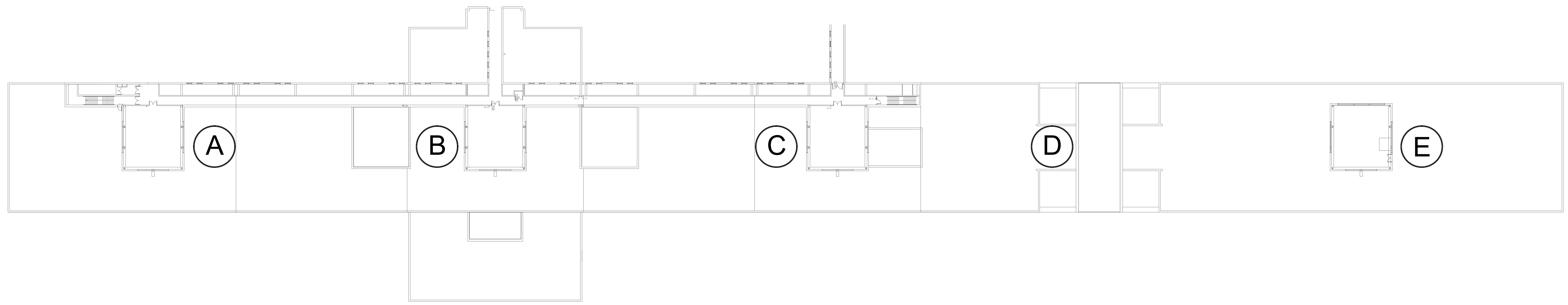

**01 OVERALL PLAN - BUILDING 19**  
 SCALE: 1/32"=1'-0"

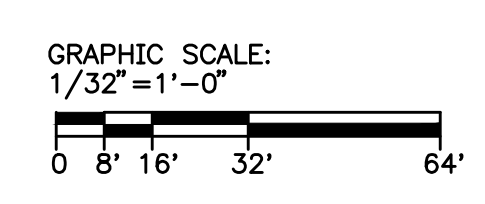
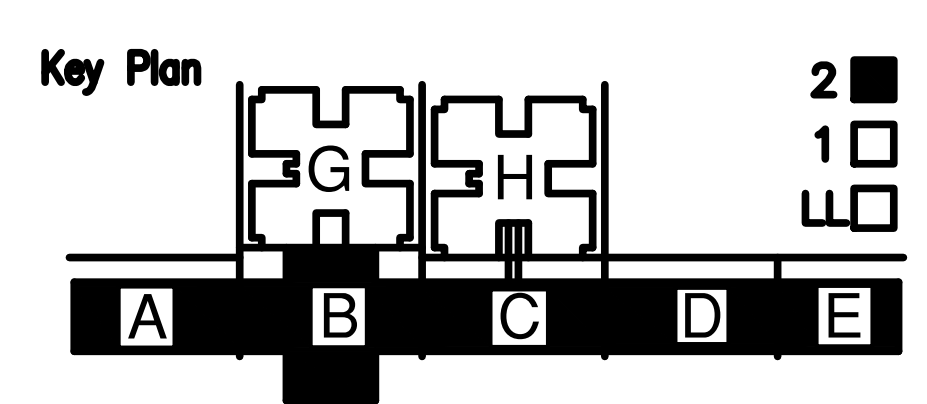

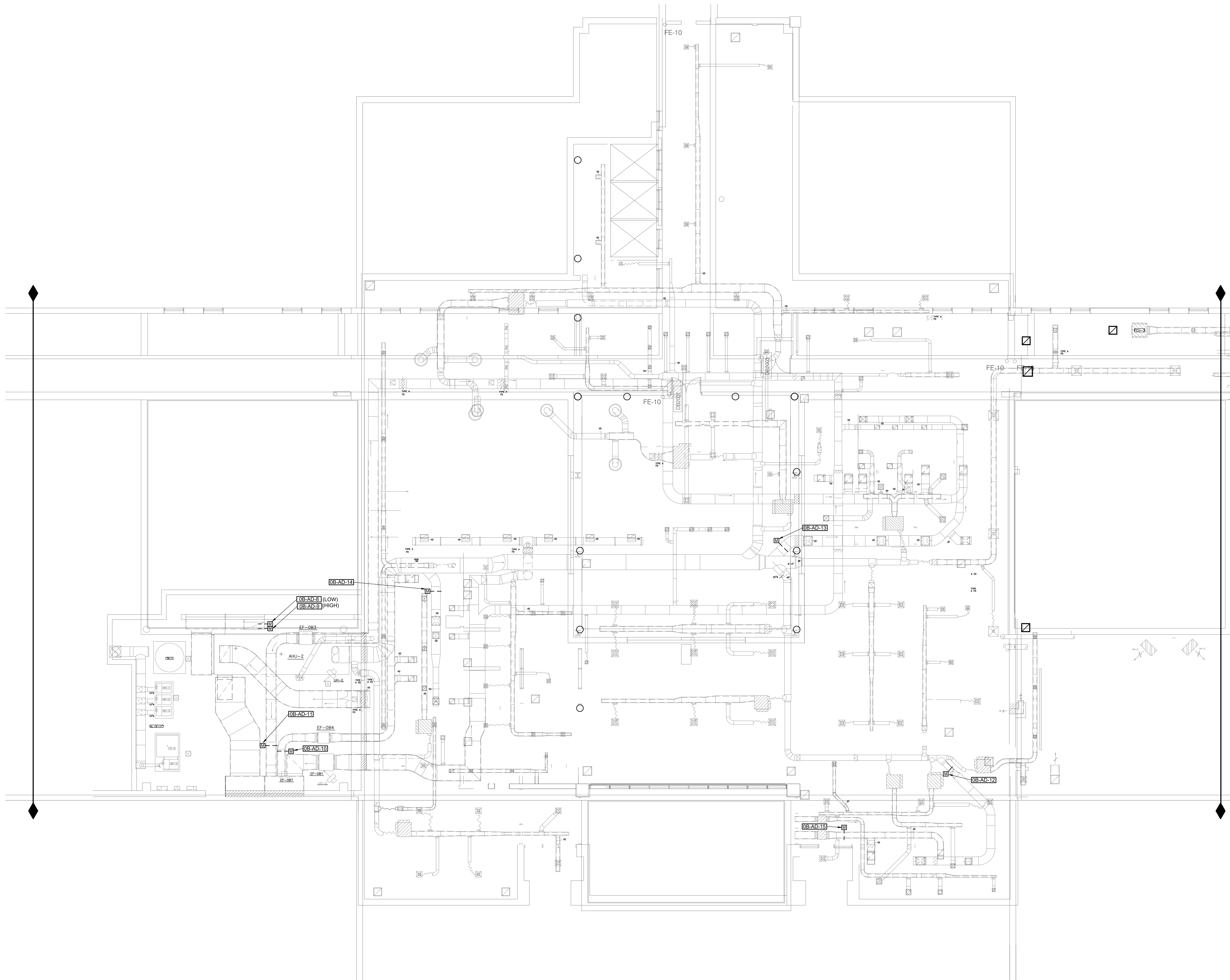

**GENERAL NOTES**

1. ALL EXISTING DAMPER ACTUATORS ARE CURRENTLY PNEUMATIC AND SHALL BE CHANGED TO ELECTRONIC.
2. SEE PLAN SHEETS M0.0 & E0.0 FOR NOTES, SYMBOLS, AND ABBREVIATIONS. REFER TO SPECIFICATIONS FOR ADDITIONAL PROJECT REQUIREMENTS.
3. REFER TO DIVISION 15 (23) BOOK SPECIFICATIONS FOR HVAC SPECIFICATIONS AND TO DIVISION 26 ELECTRICAL SPECIFICATIONS.
4. NEW ELECTRONIC ACTUATORS WILL REQUIRE 24V AT THE ACTUATORS AND 120V AT THE HEAD-END EQUIPMENT. THE ELECTRICAL CONTRACTOR SHALL BE RESPONSIBLE FOR VOLTAGE REQUIREMENTS AND CONNECTIONS TO BE MADE. COORDINATE WITH THE MECHANICAL CONTRACTOR FOR EXACT LOCATIONS OF BOTH 24V AND 120V POWER LOCATIONS.
5. VOLTAGE SHALL BE EMERGENCY BACKUP POWER ONLY. PULL ALL CIRCUITS FROM PANELBOARDS ON THE EMERGENCY GENERATOR. UTILIZE ALL SPARE 20A 1P CIRCUIT BREAKERS FROM EMERGENCY PANELS. AS REQUIRED PROVIDE A 20AMP 1P CIRCUIT BREAKER IN SPACES. PLACE NO MORE THAN 1800WATTS PER 20A 120V CIRCUIT. PROVIDE A TYPED UPDATED PANEL SCHEDULE FOR ALL PANEL BOARDS WITH NEW CIRCUIT DESIGNATIONS.
6. PROVIDE ACOUSTIC SEAL AT ALL ACOUSTIC WALLS TO DECK PENETRATIONS.
7. CONTRACT DRAWING ARE DIAGRAMMATIC. CONTRACTOR SHALL INSTALL ALL MECHANICAL ACTUATORS & ASSOCIATED MATERIALS IN ACCORDANCE WITH THE LATEST SMACNA STANDARDS.
8. COORDINATE WITH ALL TRADES BEFORE INSTALLING ANY NEW EQUIPMENT OR APPURTENANCES.

**01 BUILDING 19 LL FLOOR PLAN AREA B - MECHANICAL AND ELECTRICAL**  
SCALE: 1/8"=1'-0"

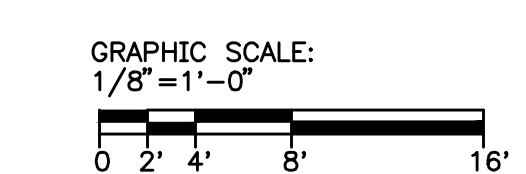
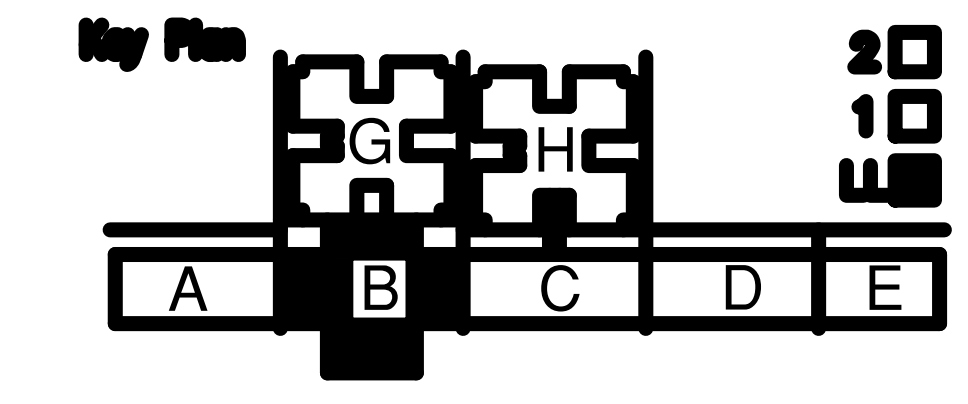

Texas Registered Firm No. F-7489  
500 North Central Expressway, Suite 310  
Ft. Worth, Texas 76104  
Email: mjb@mdeng.com  
Phone: 817-342-1939  
Project Number: 17939

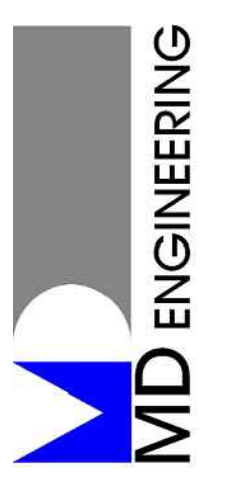

**Collin County Justice Center**  
Upgrade Pneumatic to Electronic Actuators  
4300 Community Ave. McKinney, Texas 75071

Revisions:	DATE	DESCRIPTION



LEVEL LL  
AREA B

Project No.  
**17939**

Sheet No.  
**ME2.1**

**GENERAL NOTES**

- ALL EXISTING DAMPER ACTUATORS ARE CURRENTLY PNEUMATIC AND SHALL BE CHANGED TO ELECTRONIC.
- SEE PLAN SHEETS M0.0 & E0.0 FOR NOTES, SYMBOLS, AND ABBREVIATIONS. REFER TO SPECIFICATIONS FOR ADDITIONAL PROJECT REQUIREMENTS.
- REFER TO DIVISION 15 (23) BOOK SPECIFICATIONS FOR HVAC SPECIFICATIONS AND TO DIVISION 26 ELECTRICAL SPECIFICATIONS.
- NEW ELECTRONIC ACTUATORS WILL REQUIRE 24V AT THE ACTUATORS AND 120V AT THE HEAD-END EQUIPMENT. THE ELECTRICAL CONTRACTOR SHALL BE RESPONSIBLE FOR VOLTAGE REQUIREMENTS AND CONNECTIONS TO BE MADE. COORDINATE WITH THE MECHANICAL CONTRACTOR FOR EXACT LOCATIONS OF BOTH 24V AND 120V POWER LOCATIONS.
- VOLTAGE SHALL BE EMERGENCY BACKUP POWER ONLY. PULL ALL CIRCUITS FROM PANELBOARDS ON THE EMERGENCY GENERATOR. UTILIZE ALL SPARE 20A 1P CIRCUIT BREAKERS FROM EMERGENCY PANELS AS REQUIRED. PROVIDE A 20AMP 1P CIRCUIT BREAKER IN SPACES. PLACE NO MORE THAN 1600WATTS PER 20A 120V CIRCUIT. PROVIDE A TYPED UPDATED PANEL SCHEDULE FOR ALL PANEL BOARDS WITH NEW CIRCUIT DESIGNATIONS.
- PROVIDE ACOUSTIC SEAL AT ALL ACOUSTIC WALLS TO DECK PENETRATIONS.
- CONTRACT DRAWING ARE DIAGRAMMATIC. CONTRACTOR SHALL INSTALL ALL MECHANICAL ACTUATORS & ASSOCIATED MATERIALS IN ACCORDANCE WITH THE LATEST SMACNA STANDARDS.
- COORDINATE WITH ALL TRADES BEFORE INSTALLING ANY NEW EQUIPMENT OR APPURTENANCES.

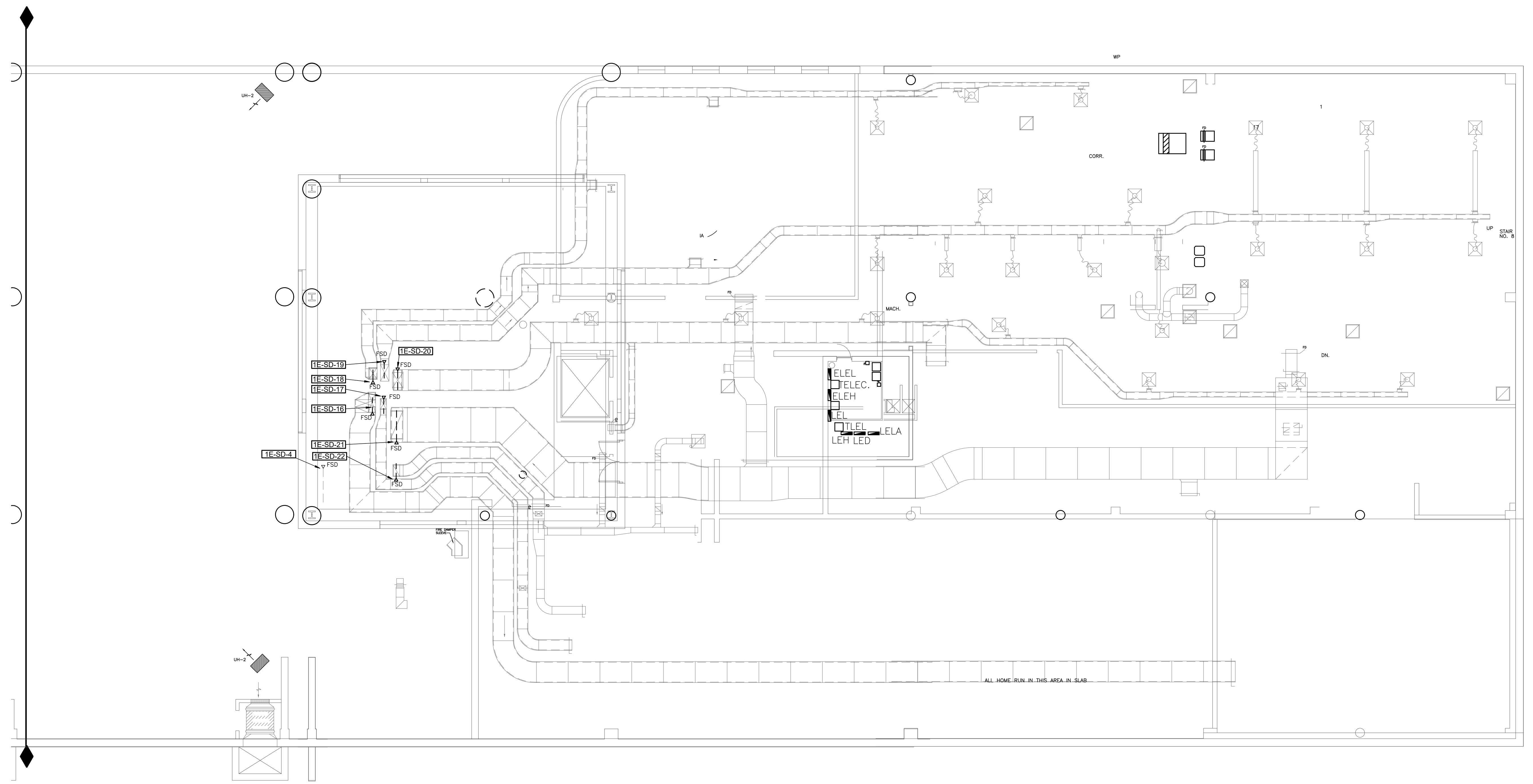

**01 BUILDING 19 LL FLOOR PLAN AREA E - MECHANICAL AND ELECTRICAL**  
 SCALE: 1/8"=1'-0"

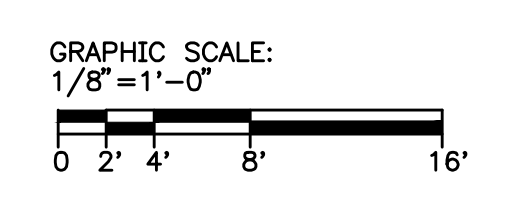
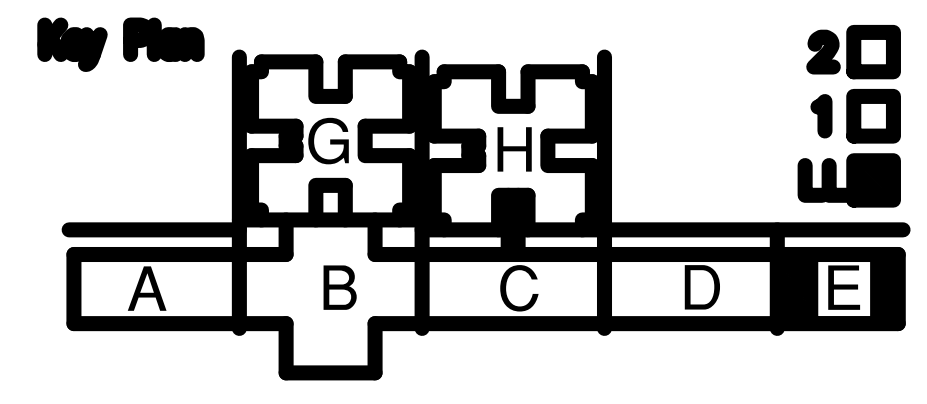

Revisions:	DESCRIPTION
DATE	



LEVEL LL  
 AREA E

Project No.  
**17939**

Sheet No.  
**ME2.2**

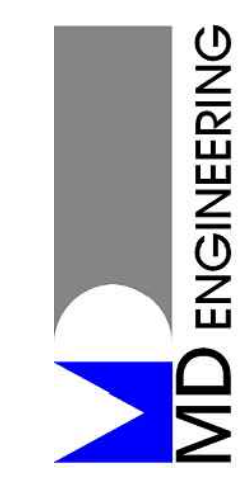

**Collin County Justice Center**  
 Upgrade Pneumatic to Electronic Actuators  
 4300 Community Ave. McKinney, Texas 75071

Revisions:	DATE	DESCRIPTION



FIRST FLOOR  
 AREA A

Project No.  
**17939**

Sheet No.  
**ME2.3**

**GENERAL NOTES**

- ALL EXISTING DAMPER ACTUATORS ARE CURRENTLY PNEUMATIC AND SHALL BE CHANGED TO ELECTRONIC.
- SEE PLAN SHEETS M0.0 & E0.0 FOR NOTES, SYMBOLS, AND ABBREVIATIONS. REFER TO SPECIFICATIONS FOR ADDITIONAL PROJECT REQUIREMENTS.
- REFER TO DIVISION 15 (23) BOOK SPECIFICATIONS FOR HVAC SPECIFICATIONS AND TO DIVISION 26 ELECTRICAL SPECIFICATIONS.
- NEW ELECTRONIC ACTUATORS WILL REQUIRE 24V AT THE ACTUATORS AND 120V AT THE HEAD-END EQUIPMENT. THE ELECTRICAL CONTRACTOR SHALL BE RESPONSIBLE FOR VOLTAGE REQUIREMENTS AND CONNECTIONS TO BE MADE. COORDINATE WITH THE MECHANICAL CONTRACTOR FOR EXACT LOCATIONS OF BOTH 24V AND 120V POWER LOCATIONS.
- VOLTAGE SHALL BE EMERGENCY BACKUP POWER ONLY. PULL ALL CIRCUITS FROM PANELBOARDS ON THE EMERGENCY GENERATOR. UTILIZE ALL SPARE 20A 1P CIRCUIT BREAKERS FROM EMERGENCY PANELS AS REQUIRED PROVIDE A 20AMP 1P CIRCUIT BREAKER IN SPACES. PLACE NO MORE THAN 1600WATTS PER 20A 120V CIRCUIT. PROVIDE A TYPED UPDATED PANEL SCHEDULE FOR ALL PANEL BOARDS WITH NEW CIRCUIT DESIGNATIONS.
- PROVIDE ACOUSTIC SEAL AT ALL ACOUSTIC WALLS TO DECK PENETRATIONS.
- CONTRACT DRAWING ARE DIAGRAMMATIC. CONTRACTOR SHALL INSTALL ALL MECHANICAL ACTUATORS & ASSOCIATED MATERIALS IN ACCORDANCE WITH THE LATEST SMACNA STANDARDS.
- COORDINATE WITH ALL TRADES BEFORE INSTALLING ANY NEW EQUIPMENT OR APPURTENANCES.

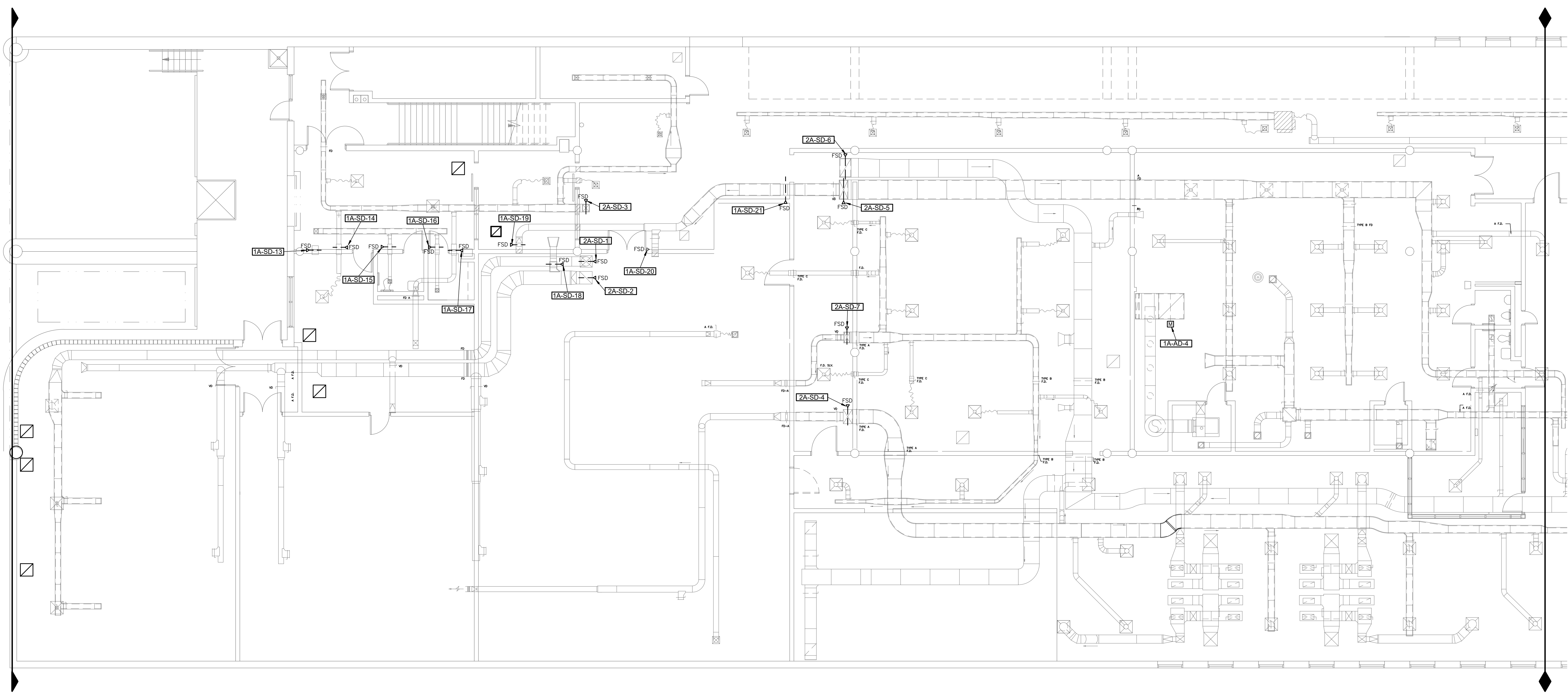

**01** BUILDING 19 FIRST FLOOR PLAN AREA A - MECHANICAL AND ELECTRICAL  
 SCALE: 1/8"=1'-0"

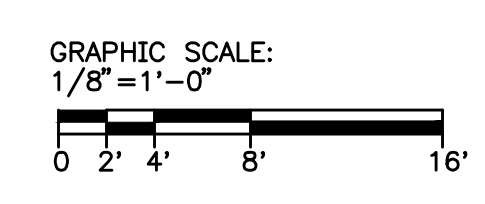
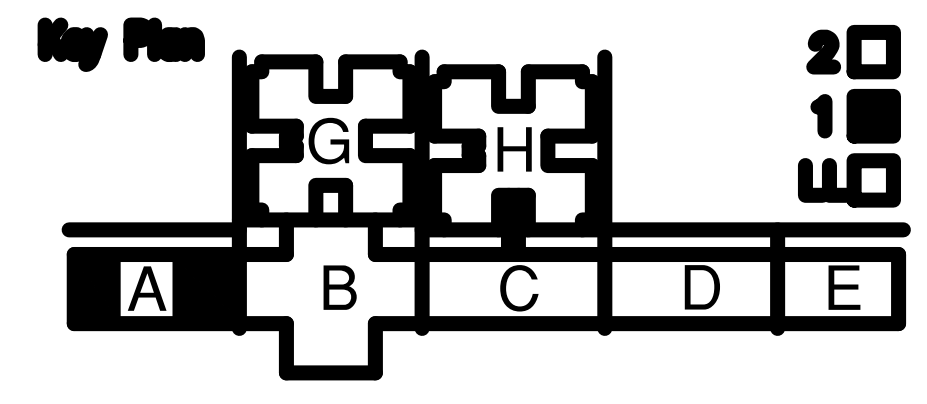

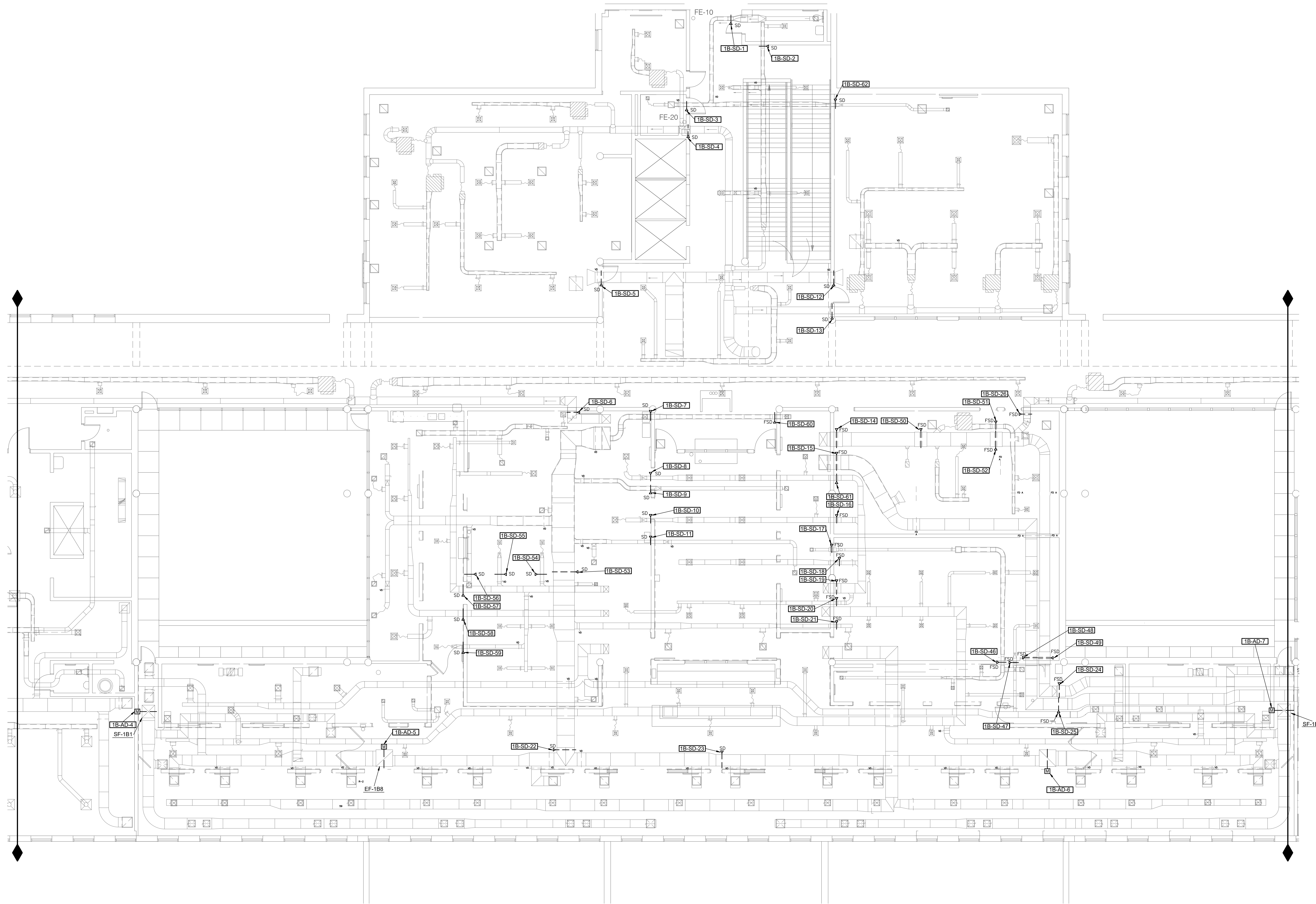

### GENERAL NOTES

- ALL EXISTING DAMPER ACTUATORS ARE CURRENTLY PNEUMATIC AND SHALL BE CHANGED TO ELECTRONIC.
- SEE PLAN SHEETS M0.0 & E0.0 FOR NOTES, SYMBOLS, AND ABBREVIATIONS. REFER TO SPECIFICATIONS FOR ADDITIONAL PROJECT REQUIREMENTS.
- REFER TO DIVISION 15 (23) BOOK SPECIFICATIONS FOR HVAC SPECIFICATIONS AND TO DIVISION 26 ELECTRICAL SPECIFICATIONS.
- NEW ELECTRONIC ACTUATORS WILL REQUIRE 24V AT THE ACTUATORS AND 120V AT THE HEAD-END EQUIPMENT. THE ELECTRICAL CONTRACTOR SHALL BE RESPONSIBLE FOR VOLTAGE REQUIREMENTS AND CONNECTIONS TO BE MADE. COORDINATE WITH THE MECHANICAL CONTRACTOR FOR EXACT LOCATIONS OF BOTH 24V AND 120V POWER LOCATIONS.
- VOLTAGE SHALL BE EMERGENCY BACKUP POWER ONLY. PULL ALL CIRCUITS FROM PANELBOARDS ON THE EMERGENCY GENERATOR. UTILIZE ALL SPARE 20A 1P CIRCUIT BREAKERS FROM EMERGENCY PANELS. AS REQUIRED PROVIDE A 20AMP 1P CIRCUIT BREAKER IN SPACES. PLACE NO MORE THAN 1600WATTS PER 20A 120V CIRCUIT. PROVIDE A TYPED UPDATED PANEL SCHEDULE FOR ALL PANEL BOARDS WITH NEW CIRCUIT DESIGNATIONS.
- PROVIDE ACOUSTIC SEAL AT ALL ACOUSTIC WALLS TO DECK PENETRATIONS.
- CONTRACT DRAWING ARE DIAGRAMMATIC. CONTRACTOR SHALL INSTALL ALL MECHANICAL ACTUATORS & ASSOCIATED MATERIALS IN ACCORDANCE WITH THE LATEST SMACNA STANDARDS.
- COORDINATE WITH ALL TRADES BEFORE INSTALLING ANY NEW EQUIPMENT OR APPURTENANCES.

**01** BUILDING 19 FIRST FLOOR PLAN AREA B - MECHANICAL AND ELECTRICAL  
SCALE: 1/8"=1'-0"

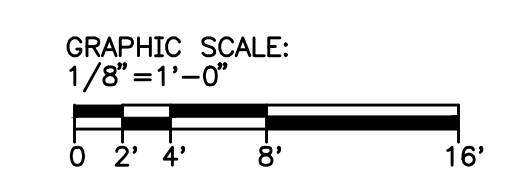
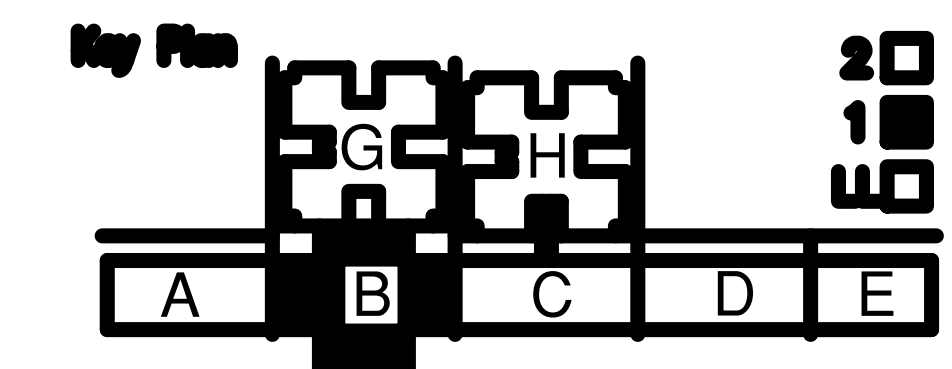

Texas Registered Firm No. F-7489  
500 North Central Expressway, Suite 310  
Ft. Worth, Texas 76102  
Email: mdr@mdeng.com  
Project Number: 17939

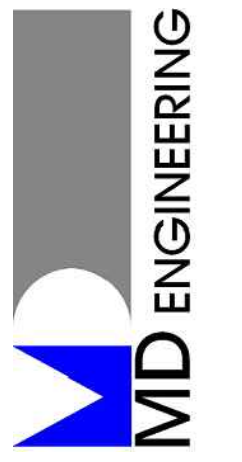

Collin County Justice Center  
Upgrade Pneumatic to Electronic Actuators  
4300 Community Ave. McKinney, Texas 75071

Revisions:	DATE	DESCRIPTION



FIRST FLOOR  
AREA B

Project No.  
**17939**

Sheet No.  
**ME2.4**

### GENERAL NOTES

- ALL EXISTING DAMPER ACTUATORS ARE CURRENTLY PNEUMATIC AND SHALL BE CHANGED TO ELECTRONIC.
- SEE PLAN SHEETS M0.0 & E0.0 FOR NOTES, SYMBOLS, AND ABBREVIATIONS. REFER TO SPECIFICATIONS FOR ADDITIONAL PROJECT REQUIREMENTS.
- REFER TO DIVISION 15 (23) BOOK SPECIFICATIONS FOR HVAC SPECIFICATIONS AND TO DIVISION 26 ELECTRICAL SPECIFICATIONS.
- NEW ELECTRONIC ACTUATORS WILL REQUIRE 24V AT THE ACTUATORS AND 120V AT THE HEAD-END EQUIPMENT. THE ELECTRICAL CONTRACTOR SHALL BE RESPONSIBLE FOR VOLTAGE REQUIREMENTS AND CONNECTIONS TO BE MADE. COORDINATE WITH THE MECHANICAL CONTRACTOR FOR EXACT LOCATIONS OF BOTH 24V AND 120V POWER LOCATIONS.
- VOLTAGE SHALL BE EMERGENCY BACKUP POWER ONLY. PULL ALL CIRCUITS FROM PANELBOARDS ON THE EMERGENCY GENERATOR. UTILIZE ALL SPARE 20A 1P CIRCUIT BREAKERS FROM EMERGENCY PANELS, AS REQUIRED PROVIDE A 20AMP 1P CIRCUIT BREAKER IN SPACES. PLACE NO MORE THAN 1600WATTS PER 20A 120V CIRCUIT. PROVIDE A TYPED UPDATED PANEL SCHEDULE FOR ALL PANEL BOARDS WITH NEW CIRCUIT DESIGNATIONS.
- PROVIDE ACOUSTIC SEAL AT ALL ACOUSTIC WALLS TO DECK PENETRATIONS.
- CONTRACT DRAWING ARE DIAGRAMMATIC. CONTRACTOR SHALL INSTALL ALL MECHANICAL ACTUATORS & ASSOCIATED MATERIALS IN ACCORDANCE WITH THE LATEST SMACNA STANDARDS.
- COORDINATE WITH ALL TRADES BEFORE INSTALLING ANY NEW EQUIPMENT OR APPURTENANCES.

Texas Registered Firm No. F-7489  
 500 North Central Expressway, Suite 310  
 Irving, TX 75038  
 Email: mjb@mdeng.com  
 Project Number: 17939

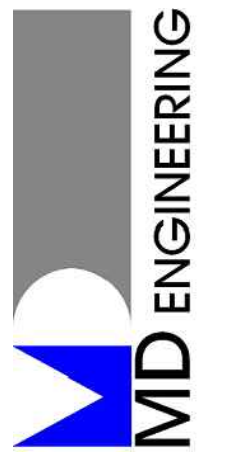

Collin County Justice Center  
 Upgrade Pneumatic to Electronic Actuators  
 4300 Community Ave. McKinney, Texas 75071

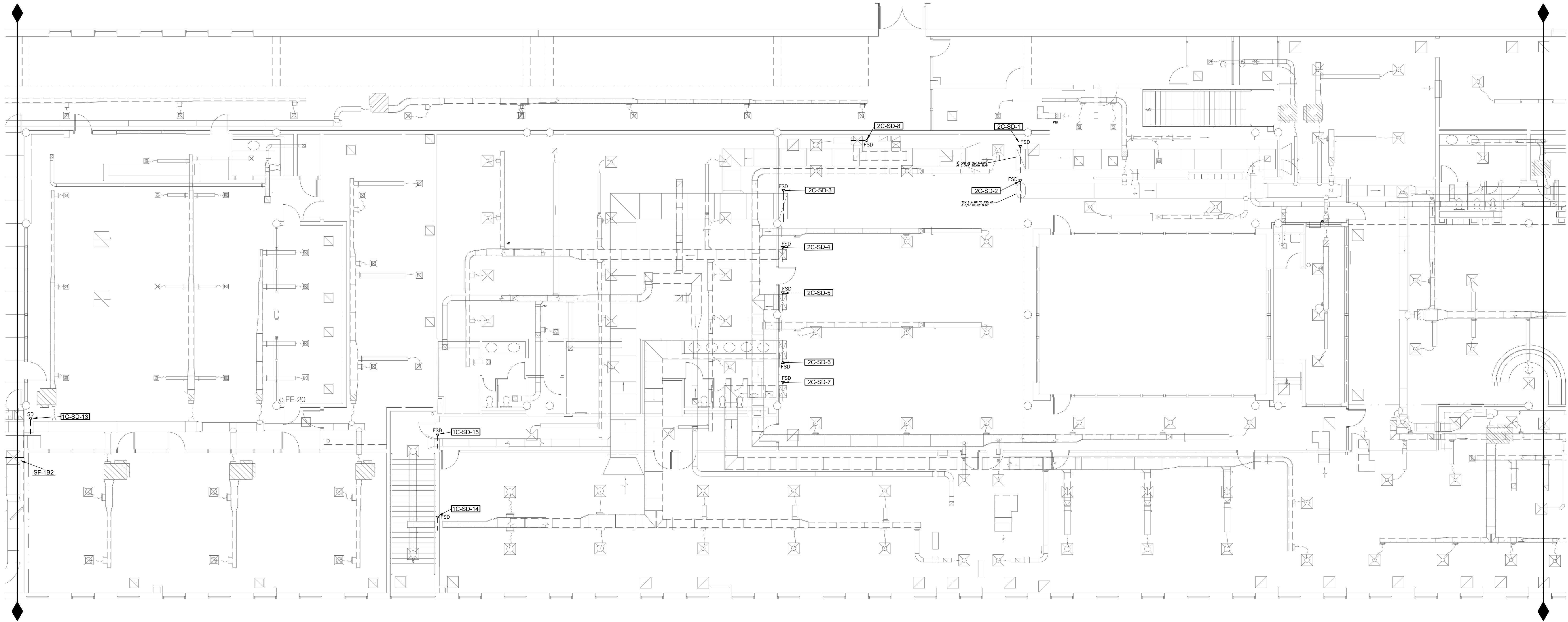

**01** BUILDING 19 FIRST FLOOR PLAN AREA C - MECHANICAL AND ELECTRICAL  
 SCALE: 1/8"=1'-0"

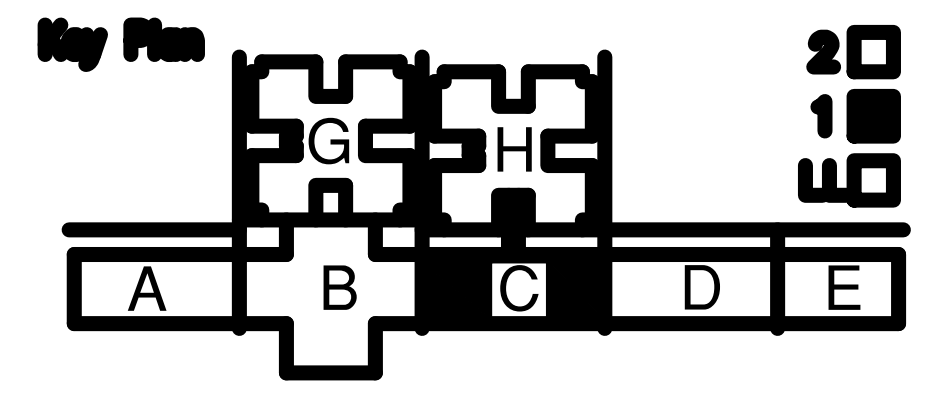

GRAPHIC SCALE:  
 1/8" = 1'-0"  
 0 2' 4' 8' 16'

Revisions:	DESCRIPTION
DATE	



FIRST FLOOR  
 AREA C

Project No.  
**17939**

Sheet No.  
**ME2.5**



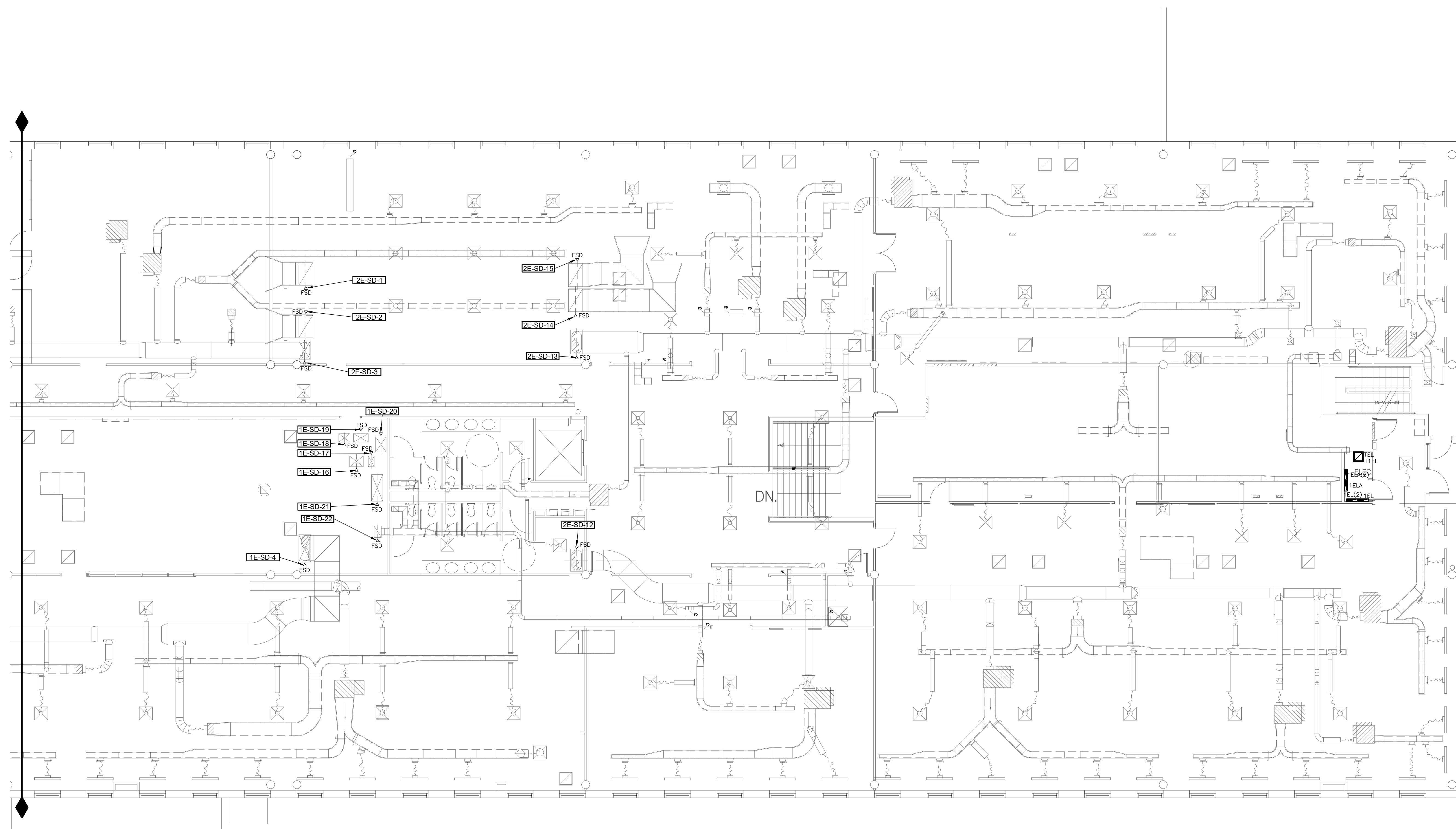

### GENERAL NOTES

- ALL EXISTING DAMPER ACTUATORS ARE CURRENTLY PNEUMATIC AND SHALL BE CHANGED TO ELECTRONIC.
- SEE PLAN SHEETS MD.0 & ED.0 FOR NOTES, SYMBOLS, AND ABBREVIATIONS. REFER TO SPECIFICATIONS FOR ADDITIONAL PROJECT REQUIREMENTS.
- REFER TO DIVISION 15 (23) BOOK SPECIFICATIONS FOR HVAC SPECIFICATIONS AND TO DIVISION 26 ELECTRICAL SPECIFICATIONS.
- NEW ELECTRONIC ACTUATORS WILL REQUIRE 24V AT THE ACTUATORS AND 120V AT THE HEAD-END EQUIPMENT. THE ELECTRICAL CONTRACTOR SHALL BE RESPONSIBLE FOR VOLTAGE REQUIREMENTS AND CONNECTIONS TO BE MADE. COORDINATE WITH THE MECHANICAL CONTRACTOR FOR EXACT LOCATIONS OF BOTH 24V AND 120V POWER LOCATIONS.
- VOLTAGE SHALL BE EMERGENCY BACKUP POWER ONLY. PULL ALL CIRCUITS FROM PANELBOARDS ON THE EMERGENCY GENERATOR. UTILIZE ALL SPARE 20A 1P CIRCUIT BREAKERS FROM EMERGENCY PANELS. AS REQUIRED PROVIDE A 20AMP 1P CIRCUIT BREAKER IN SPACES. PLACE NO MORE THAN 150WATTS PER 20A 120V CIRCUIT. PROVIDE A TYPED UPDATED PANEL SCHEDULE FOR ALL PANEL BOARDS WITH NEW CIRCUIT DESIGNATIONS.
- PROVIDE ACOUSTIC SEAL AT ALL ACOUSTIC WALLS TO DECK PENETRATIONS.
- CONTRACT DRAWING ARE DIAGRAMMATIC. CONTRACTOR SHALL INSTALL ALL MECHANICAL ACTUATORS & ASSOCIATED MATERIALS IN ACCORDANCE WITH THE LATEST SMACNA STANDARDS.
- COORDINATE WITH ALL TRADES BEFORE INSTALLING ANY NEW EQUIPMENT OR APPURTENANCES.

## 01 BUILDING 19 FIRST FLOOR PLAN AREA E - MECHANICAL AND ELECTRICAL

SCALE: 1/8"=1'-0"

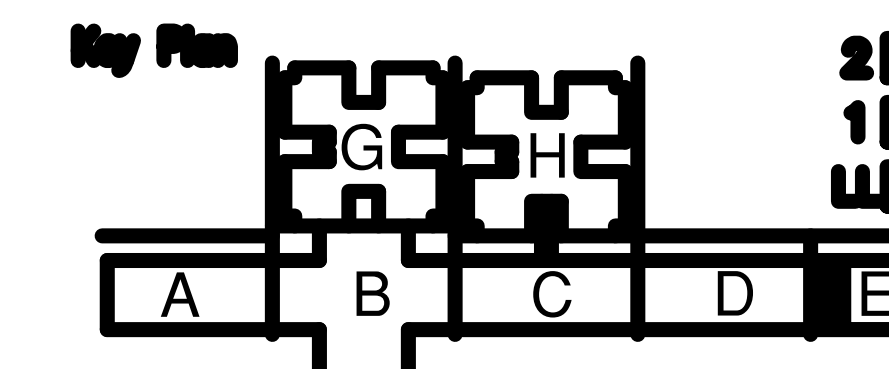

GRAPHIC SCALE:  
1/8"=1'-0"  
0 2' 4' 8' 16'

Texas Registered Firm No. F-7489  
500 North Central Expressway, Suite 310  
Frisco, TX 75034  
Phone: 972.261.1939  
Fax: 972.261.1939  
Email: info@mdeng.com  
Project Number: 17939



Collin County Justice Center  
Upgrade Pneumatic to Electronic Actuators  
4300 Community Ave. McKinney, Texas 75071

Revisions:  
DATE DESCRIPTION



FIRST FLOOR  
AREA E

Project No.  
**17939**

Sheet No.  
**ME2.6**

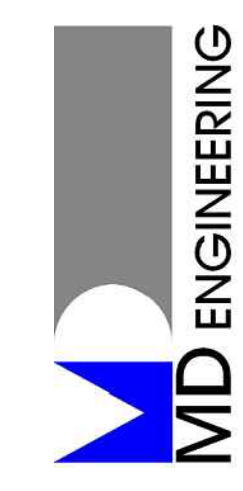

Collin County Justice Center  
 Upgrade Pneumatic to Electronic Actuators  
 4300 Community Ave. McKinney, Texas 75071

Revisions:	DATE	DESCRIPTION



SECOND FLOOR  
 AREA A

Project No.  
**17939**

Sheet No.  
**ME2.7**

**GENERAL NOTES**

- ALL EXISTING DAMPER ACTUATORS ARE CURRENTLY PNEUMATIC AND SHALL BE CHANGED TO ELECTRONIC.
- SEE PLAN SHEETS M0.0 & E0.0 FOR NOTES, SYMBOLS, AND ABBREVIATIONS. REFER TO SPECIFICATIONS FOR ADDITIONAL PROJECT REQUIREMENTS.
- REFER TO DIVISION 15 (23) BOOK SPECIFICATIONS FOR HVAC SPECIFICATIONS AND TO DIVISION 26 ELECTRICAL SPECIFICATIONS.
- NEW ELECTRONIC ACTUATORS WILL REQUIRE 24V AT THE ACTUATORS AND 120V AT THE HEAD-END EQUIPMENT. THE ELECTRICAL CONTRACTOR SHALL BE RESPONSIBLE FOR VOLTAGE REQUIREMENTS AND CONNECTIONS TO BE MADE. COORDINATE WITH THE MECHANICAL CONTRACTOR FOR EXACT LOCATIONS OF BOTH 24V AND 120V POWER LOCATIONS.
- VOLTAGE SHALL BE EMERGENCY BACKUP POWER ONLY. PULL ALL CIRCUITS FROM PANELBOARDS ON THE EMERGENCY GENERATOR. UTILIZE ALL SPARE 20A 1P CIRCUIT BREAKERS FROM EMERGENCY PANELS AS REQUIRED PROVIDE A 20AMP 1P CIRCUIT BREAKER IN SPACES. PLACE NO MORE THAN 1600WATTS PER 20A 120V CIRCUIT. PROVIDE A TYPED UPDATED PANEL SCHEDULE FOR ALL PANEL BOARDS WITH NEW CIRCUIT DESIGNATIONS.
- PROVIDE ACOUSTIC SEAL AT ALL ACOUSTIC WALLS TO DECK PENETRATIONS.
- CONTRACT DRAWING ARE DIAGRAMMATIC. CONTRACTOR SHALL INSTALL ALL MECHANICAL ACTUATORS & ASSOCIATED MATERIALS IN ACCORDANCE WITH THE LATEST SMACNA STANDARDS.
- COORDINATE WITH ALL TRADES BEFORE INSTALLING ANY NEW EQUIPMENT OR APPURTENANCES.

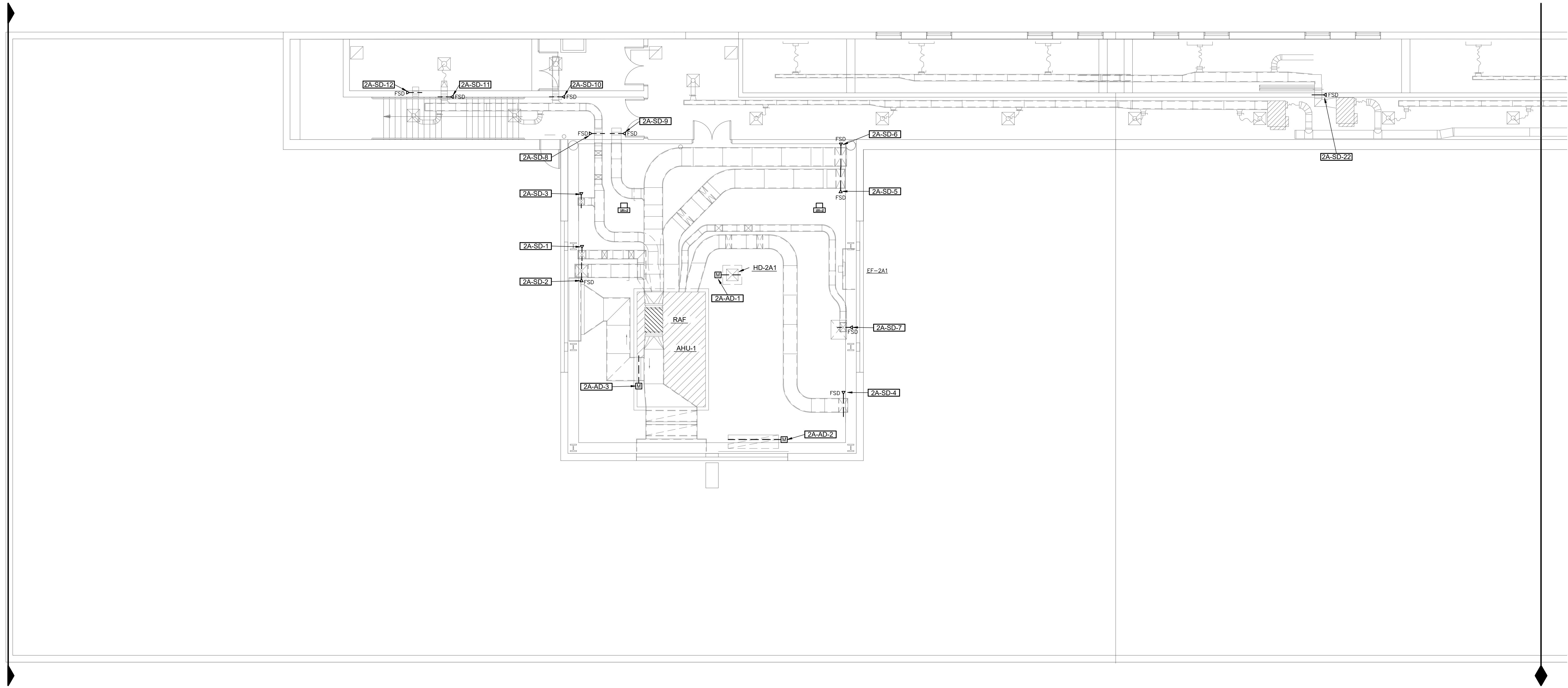

**01** BUILDING 19 SECOND FLOOR PLAN AREA A - MECHANICAL AND ELECTRICAL  
 SCALE: 1/8"=1'-0"

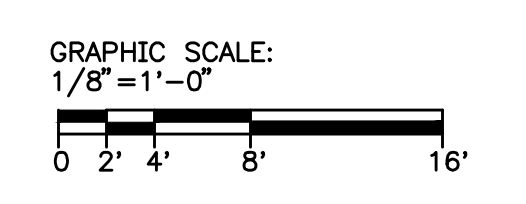
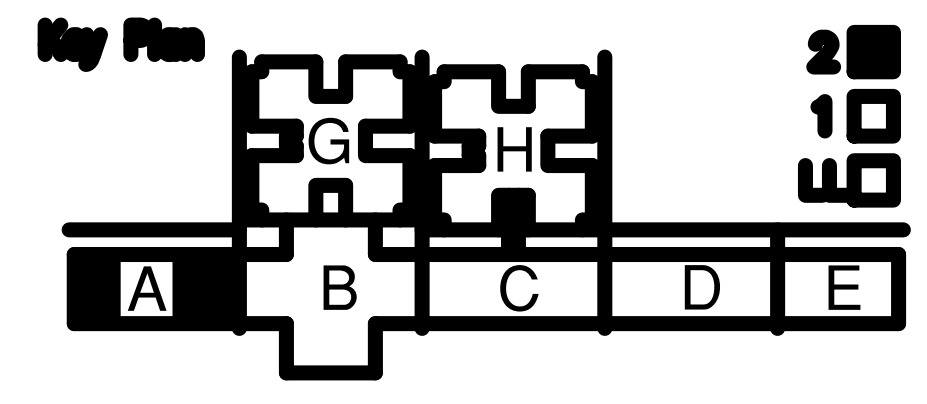



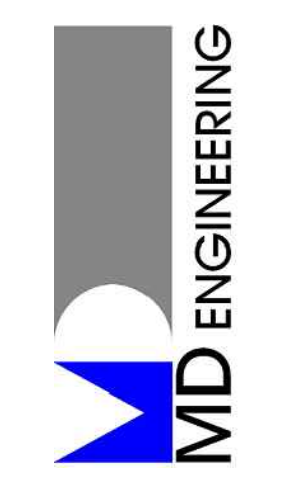

**Collin County Justice Center**  
 Upgrade Pneumatic to Electronic Actuators  
 4300 Community Ave. McKinney, Texas 75071

Revisions:	DATE	DESCRIPTION



SECOND FLOOR  
 AREA C

Project No.  
**17939**

Sheet No.  
**ME2.9**

**GENERAL NOTES**

1. ALL EXISTING DAMPER ACTUATORS ARE CURRENTLY PNEUMATIC AND SHALL BE CHANGED TO ELECTRONIC.
2. SEE PLAN SHEETS M0.0 & E0.0 FOR NOTES, SYMBOLS, AND ABBREVIATIONS. REFER TO SPECIFICATIONS FOR ADDITIONAL PROJECT REQUIREMENTS.
3. REFER TO DIVISION 15 (23) BOOK SPECIFICATIONS FOR HVAC SPECIFICATIONS AND TO DIVISION 26 ELECTRICAL SPECIFICATIONS.
4. NEW ELECTRONIC ACTUATORS WILL REQUIRE 24V AT THE ACTUATORS AND 120V AT THE HEAD-END EQUIPMENT. THE ELECTRICAL CONTRACTOR SHALL BE RESPONSIBLE FOR VOLTAGE REQUIREMENTS AND CONNECTIONS TO BE MADE. COORDINATE WITH THE MECHANICAL CONTRACTOR FOR EXACT LOCATIONS OF BOTH 24V AND 120V POWER LOCATIONS.
5. VOLTAGE SHALL BE EMERGENCY BACKUP POWER ONLY. PULL ALL CIRCUITS FROM PANELBOARDS ON THE EMERGENCY GENERATOR. UTILIZE ALL SPARE 20A 1P CIRCUIT BREAKERS FROM EMERGENCY PANELS. AS REQUIRED PROVIDE A 20AMP 1P CIRCUIT BREAKER IN SPACES. PLACE NO MORE THAN 1600WATTS PER 20A 120V CIRCUIT. PROVIDE A TYPED UPDATED PANEL SCHEDULE FOR ALL PANEL BOARDS WITH NEW CIRCUIT DESIGNATIONS.
6. PROVIDE ACOUSTIC SEAL AT ALL ACOUSTIC WALLS TO DECK PENETRATIONS.
7. CONTRACT DRAWING ARE DIAGRAMMATIC. CONTRACTOR SHALL INSTALL ALL MECHANICAL ACTUATORS & ASSOCIATED MATERIALS IN ACCORDANCE WITH THE LATEST SMACNA STANDARDS.
8. COORDINATE WITH ALL TRADES BEFORE INSTALLING ANY NEW EQUIPMENT OR APPURTENANCES.

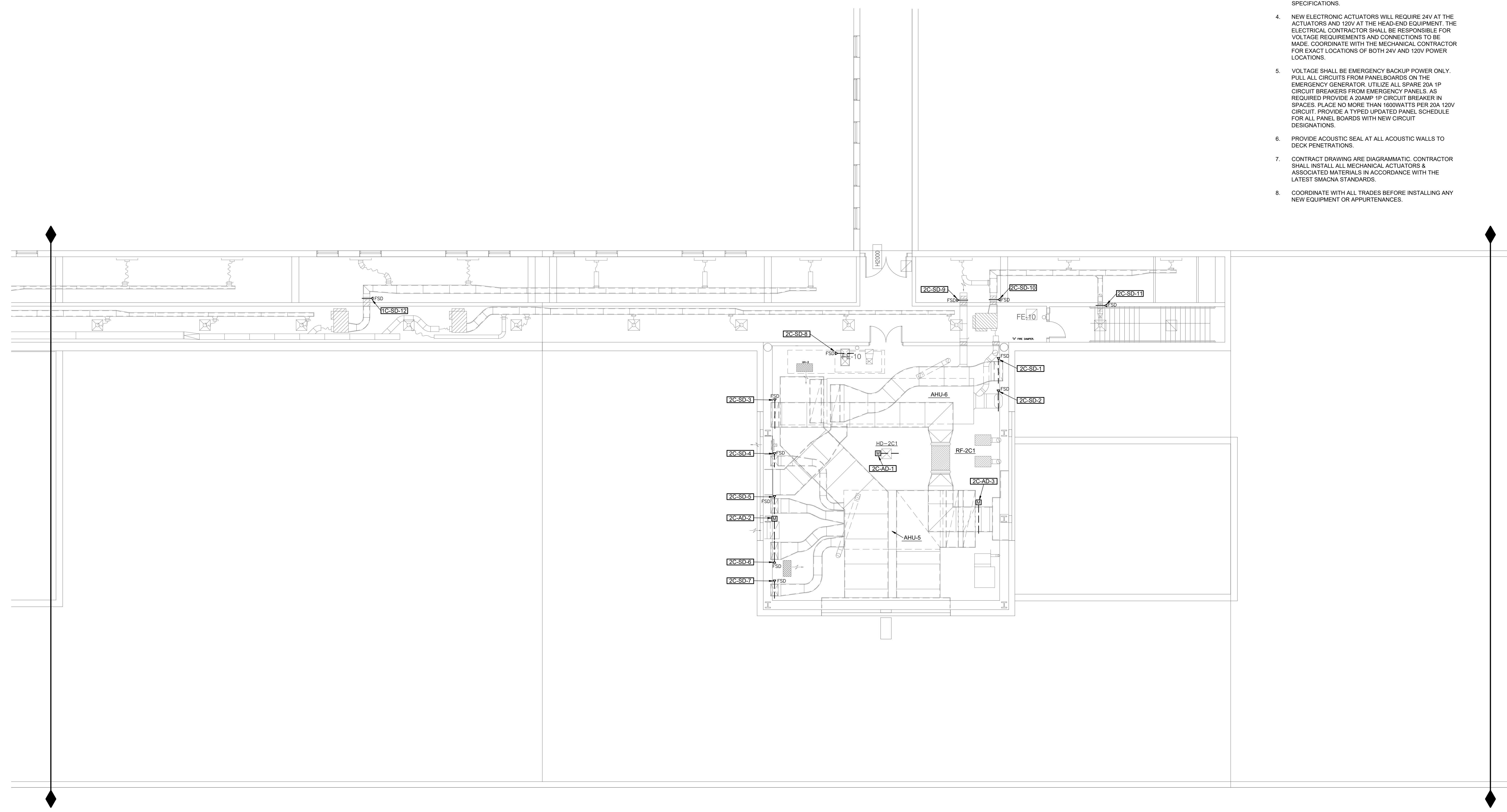

**01 BUILDING 19 SECOND FLOOR PLAN AREA C - MECHANICAL AND ELECTRICAL**  
 SCALE: 1/8"=1'-0"

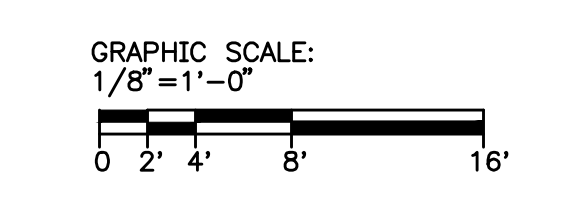
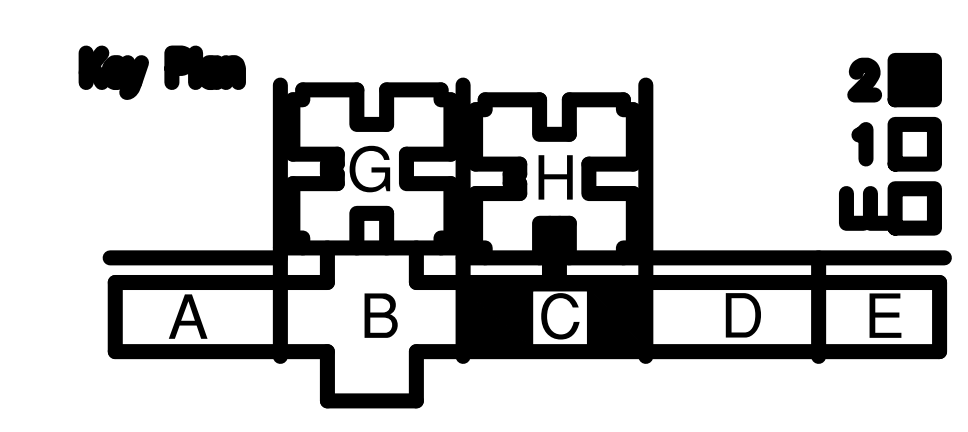

M:\2017\17939\Collin County Justice Center\ME2.9.dwg (2018-02-21 10:00:00) (2018-02-21 10:00:00) (2018-02-21 10:00:00) (2018-02-21 10:00:00) (2018-02-21 10:00:00)



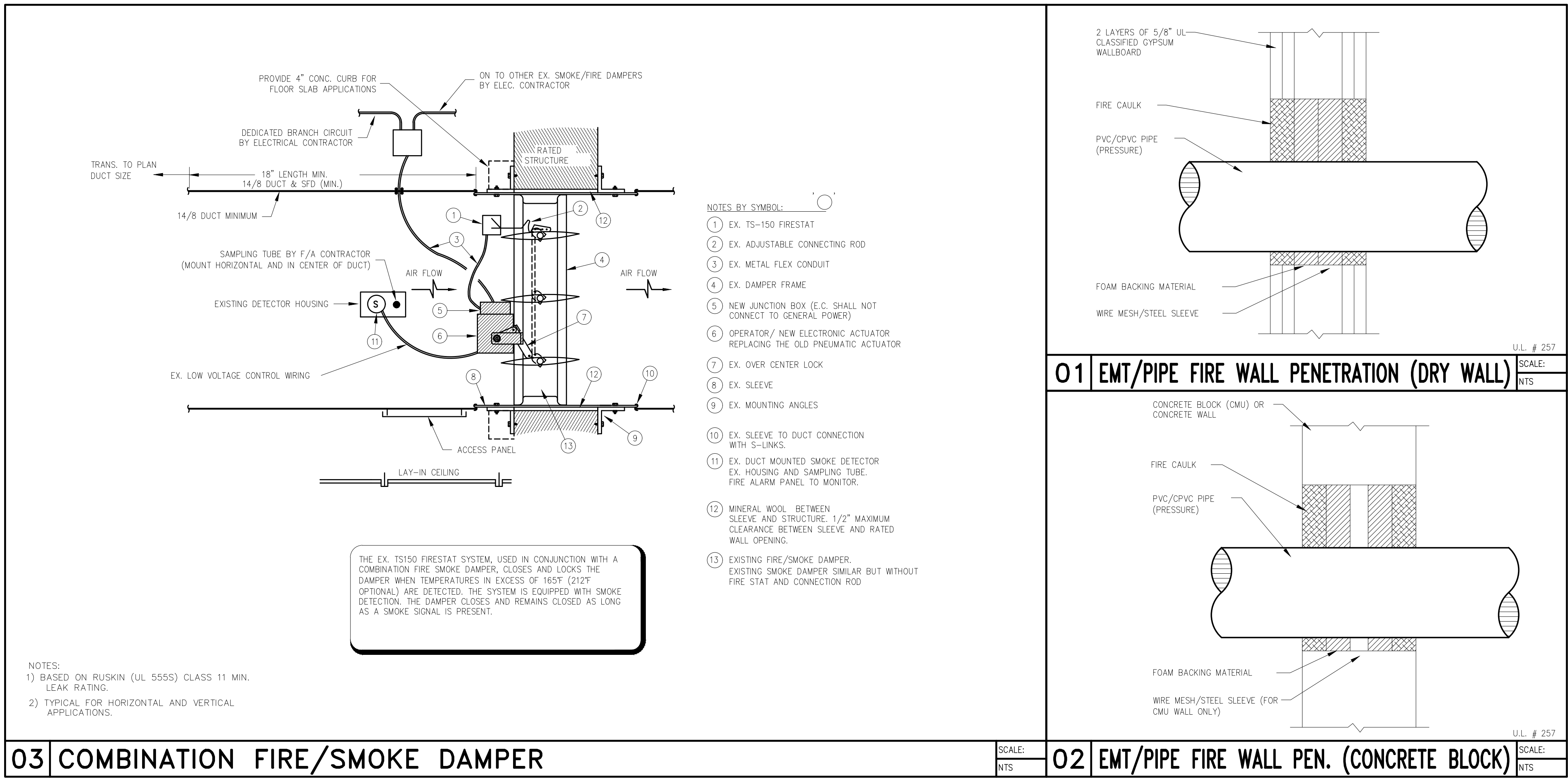

**03 COMBINATION FIRE/SMOKE DAMPER**

**01 EMT/PIPE FIRE WALL PENETRATION (DRY WALL)**

**02 EMT/PIPE FIRE WALL PEN. (CONCRETE BLOCK)**

Texas Registered Firm No. F-7489  
 500 North Central Expressway, Suite 310  
 Irving, Texas 75038  
 Phone: 972.467.0200  
 Fax: 972.467.0200  
 Email: mjb@mdeng.com  
 Project Number: 17939

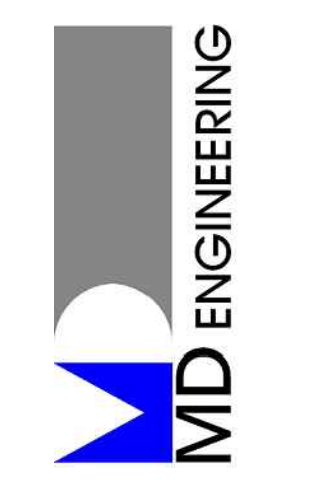

**Collin County Justice Center**  
 Upgrade Pneumatic to Electronic Actuators  
 4300 Community Ave. McKinney, Texas 75071

Revisions:	DATE	DESCRIPTION

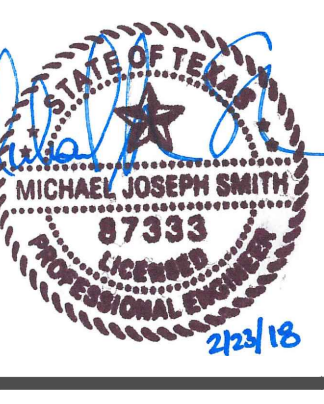

MECHANICAL  
ELECTRICAL  
DETAILS

Project No.  
**17939**

Sheet No.  
**ME3.1**

**ELECTRICAL ABBREVIATIONS**

(ALL ABBREVIATIONS MAY NOT APPEAR ON DRAWINGS.)

2SCP	2-SPEED, CONSEQUENT POLE	FLEX	FLEXIBLE	NFS	NON-FUSIBLE SAFETY SWITCH
2SSW	2-SPEED, SEPARATE WINDING	FS	FUSIBLE SAFETY SWITCH OR FUSIBLE SWITCH	NIC	NOT IN CONTRACT
A	AMPERE(S)	FVNR	FULL VOLTAGE, NON-REVERSING	NL	NIGHT LIGHT
AC	ALTERNATING CURRENT	FVR	FULL VOLTAGE, REVERSING	NO	NORMALLY OPEN
ACCU	AIR-COOLED CONDENSING UNIT	G	GROUND	NTS	NOT TO SCALE
ADA	AMERICANS WITH DISABILITIES ACT	GFCI	GROUND FAULT CIRCUIT INTERRUPT	OH	OVERHEAD
AFF	ABOVE FINISHED FLOOR	HACR	HEATING AND AIR CONDITIONING RATING	P	POLE(S)
AFC	ABOVE FINISHED CEILING	HID	HIGH INTENSITY DISCHARGE	PA	PUBLIC ADDRESS SYSTEM
AFG	ABOVE FINISHED GRADE	HOA	HAND-OFF-AUTOMATIC	PF	POWER FACTOR
AHU	AIR HANDLING UNIT	HP	HORSEPOWER	PL	PILOT LIGHT
AIC	AMPERE INTERRUPTING CAPACITY (ROOT MEAN SQUARE SYMMETRICAL)	HPS	HIGH PRESSURE SODIUM	PNL	PANELBOARD
ALT	ALTERNATE	HVAC	HEATING, VENTILATION AND AIR CONDITIONING	PVC	POLYVINYL CHLORIDE
APPROX	APPROXIMATE OR APPROXIMATELY	HZ	HERTZ	RC	REMOTE CONTROL
ARCH	ARCHITECT	IES	ILLUMINATING ENGINEERING SOCIETY OF NORTH AMERICA	RCP	REFLECTED CEILING PLAN
ATS	AUTOMATIC TRANSFER SWITCH	IG	ISOLATED GROUND	REC	RECEPTACLES(S)
AUX	AUXILIARY	IMC	INTERMEDIATE METALLIC CONDUIT	RGS	RIGID GALVANIZED STEEL
AWG	AMERICAN WIRE GAGE	IMC	INTERMEDIATE METALLIC CONDUIT	RVSS	REDUCED VOLTAGE, SOLID STATE
BFC	BELOW FINISHED CEILING	JBOX	JUNCTION BOX	SF	SQUARE FOOT OR FEET
BFG	BELOW FINISHED GRADE	KA	KILOAMPERE(S)	SPDT	SINGLE-POLE, DOUBLE-THROW
BLDG	BUILDING	KW	KILOWATT(S)	SPST	SINGLE-POLE, SINGLE-THROW
C	CONDUIT OR TUBING	KWH	KILOWATT-HOUR(S)	SS	START-STOP
CATV	CABLE TELEVISION	KV	KILOVOLT(S)	SW	SWITCH
CB	CIRCUIT BREAKER	KVA	KILOVOLT-AMPERE(S)	SWBD	SWITCHBOARD
CCTV	CLOSED-CIRCUIT TELEVISION	KVAR	KILOVOLT-AMPERE(S) REACTIVE	TA	TRIP AMPERE(S)
CKT	CIRCUIT	LPS	LOW PRESSURE SODIUM	TAS	TEXAS ACCESSIBILITY STANDARDS
CLG	CEILING	LTG	LIGHTING	TEL	TELEPHONE
COMM	COMMUNICATIONS	m	METER(S)	TEMP	TEMPORARY
CT(S)	CURRENT TRANSFORMER(S)	MAX	MAXIMUM	TU	TEXAS UTILITIES ELECTRIC
DC	DIRECT CURRENT	MCA	MAXIMUM CURRENT AMPACITY	TV	TELEVISION
DISC	DISCONNECT	MCB	MAIN CIRCUIT BREAKER	TYP	TYPICAL
DPDT	DOUBLE-POLE, DOUBLE THROW	MCC	MOTOR CONTROL CENTER	UG	UNDERGROUND
DPST	DOUBLE POLE, SINGLE THROW	MCP	MOTOR CIRCUIT PROTECTOR	UL	UNDERWRITERS LABORATORIES, INC.
DWG(S)	DRAWING(S)	MH	METAL HALIDE	UPS	UNINTERRUPTIBLE POWER SUPPLY
EC	EMPTY CONDUIT OR TUBING	MIC	MICROPHONE	UNO	UNLESS NOTED OTHERWISE
EGS	ENGINE-GENERATOR SET	MIN	MINIMUM	V	VOLTAGE OR VOLT(S)
EHH	ELECTRICAL HANDHOLE	MLO	MAIN LUGS ONLY	VA	VOLT-AMPERE(S)
ELEV	ELEVATION	mm	MILLIMETER(S)	VFD	VARIABLE FREQUENCY DRIVE
EMERG	EMERGENCY	MMS	MANUAL MOTOR STARTER	W	WATT(S)
EMH	ELECTRICAL MANHOLE	MOC	MAXIMUM OVER-CURRENT PROTECTION	WP	WEATHERPROOF
EMT	ELECTRICAL METALLIC TUBING	MTS	MANUAL TRANSFER SWITCH	WI	WITH
E/R	EXISTING TO BE REMOVED AND REINSTALLED AFTER MODIFICATION	MVA	MEGAVOLT-AMPERE(S)	W/O	WITHOUT
EWC	ELECTRICAL WATER COOLER	MVAR	MEGAVOLT-AMPERE(S) REACTIVE	XFMR	TRANSFORMER
EX	EXISTING	MW	MEGAWATT(S)	XP	EXPLOSION-PROOF
F	FUSE(S)	NC	NORMALLY CLOSED		
FAAP	FIRE ALARM ANNUNCIATOR PANEL	NEC	NATIONAL ELECTRICAL CODE		
FACP	FIRE ALARM CONTROL PANEL	NEMA	NATIONAL ELECTRICAL MANUFACTURER'S ASSOCIATION	△	DELTA
FBO	FURNISHED BY OWNER	NFPA	NATIONAL FIRE PROTECTION ASSOCIATION	#	NUMBER
FL	FLOOR				
FLA	FULL LOAD AMPERE(S)				

**WIRING METHOD NOTES:**

- DO NOT COMBINE NEUTRALS AND GROUNDS OF SEPARATE BRANCH CIRCUITS.
- WIRE SHALL BE COPPER THWN - SOLID FOR SIZES 12, 10, 8; STRANDED FOR SIZES 6 AND LARGER.

**ELECTRICAL SYMBOLS LIST**

(ALL SYMBOLS MAY NOT APPEAR ON DRAWINGS.)

	— CEILING-MOUNTED SURFACE OR SUSPENDED SINGLE-FACE EXIT SIGN WITH DIRECTIONAL ARROW AS INDICATED; SHADED QUADRANT INDICATES FACE OF SIGN.	§	— SINGLE POLE SWITCH AT 48" ABOVE FINISHED FLOOR WITH SECURITY DETENTION PLATE.
	— CEILING-MOUNTED SURFACE OR SUSPENDED DOUBLE-FACE EXIT SIGN WITH DIRECTIONAL ARROWS AS INDICATED; SHADED QUADRANT INDICATES FACES OF SIGN.	§	— SINGLE-POLE SWITCH AT 48" ABOVE FINISHED FLOOR UNO.
	— WALL-MOUNTED EXIT SIGN WITH DIRECTIONAL ARROW(S) AS INDICATED; SHADED QUADRANT(S) INDICATE FACE(S) OF SIGN.	§D	— SINGLE-POLE DIMMING SWITCH AT 48" ABOVE FINISHED FLOOR UNO.
	— EMERGENCY LIGHT FIXTURE	§2	— TWO-POLE SWITCH AT 48" ABOVE FINISHED FLOOR UNO.
	— JUNCTION BOX	§3	— THREE-WAY SWITCH AT 48" ABOVE FINISHED FLOOR UNO.
	— SINGLE RECEPTACLE, NEMA 5-20R AT 18" ABOVE FINISHED FLOOR UNO.	§4	— FOUR-WAY SWITCH AT 48" ABOVE FINISHED FLOOR UNO.
	— DUPLEX RECEPTACLE, NEMA 5-20R AT 18" ABOVE FINISHED FLOOR UNO.	§K	— KEY-OPERATED SWITCH AT 48" ABOVE FINISHED FLOOR UNO.
	— QUADRUPLEX RECEPTACLE, NEMA 5-20R AT 18" ABOVE FINISHED FLOOR UNO.	§P	— SINGLE-POLE SWITCH AND PILOT LIGHT AT 48" ABOVE FINISHED FLOOR UNO.
	— RECEPTACLE WITH WEATHERPROOF COVERPLATE, DUPLEX NEMA 5-20R 18" ABOVE FINISHED GRADE OR FLOOR UNO.	§T	— TIME SWITCH AT 48" ABOVE FINISHED FLOOR UNO.
	— DUPLEX RECEPTACLE WITH DETENTION PLATE	§WP	— SINGLE-POLE SWITCH WITH WEATHERPROOF COVERPLATE AT 48" ABOVE FINISHED GRADE OR FLOOR UNO.
	— GROUND-FAULT CIRCUIT INTERRUPTER RECEPTACLE, DUPLEX NEMA 5-20R 18" ABOVE FINISHED GRADE OR FLOOR UNO.	F	— FIRE ALARM SYSTEM MANUAL PULL STATION AT 48" ABOVE FINISHED FLOOR UNO.
	— ISOLATED GROUND RECEPTACLE, DUPLEX NEMA 5-20R AT 18" ABOVE FINISHED FLOOR UNO.	F	— FIRE ALARM SYSTEM SMOKE DETECTOR, SUBSCRIPTED D INDICATES DUCT MOUNTING AND SUBSCRIPTED U INDICATES UNDER FLOOR MOUNTING.
	— RECEPTACLE MOUNTED n INCHES ABOVE FINISHED FLOOR OR GRADE, NEMA 5-20R UNO	F	— FIRE ALARM SYSTEM HEAT DETECTOR
	— RECEPTACLE 208 VOLT.	L	— FIRE ALARM SYSTEM STROBE LIGHT AT 80" AFF OR 6" BFC, WHICHEVER IS LOWER; SUBSCRIPTED 1 INDICATES 110 CANDELA INTENSITY.
	— SPECIAL-PURPOSE RECEPTACLE, SEE SPECIAL-PURPOSE RECEPTACLE, CONNECTION AND FLOOR BOX SCHEDULE ON DRAWING.	L	— FIRE ALARM SYSTEM HORN AT 90" AFF OR 6" BFC, WHICHEVER IS LOWER.
	— HARDWIRE CONNECTION OR PROVISION FOR CONNECTION, SEE SPECIAL-PURPOSE RECEPTACLE, CONNECTION AND FLOOR BOX SCHEDULE ON DRAWING.	L	— FIRE ALARM SYSTEM BELL AT 90" AFF OR 6" BFC, WHICHEVER IS LOWER.
	— MULTIOUTLET ASSEMBLY	L	— FIRE ALARM SYSTEM HORN/STROBE LIGHT AT 80" AFF OR 6" BFC, WHICHEVER IS LOWER; SUBSCRIPTED 1 INDICATES 110 CANDELA INTENSITY.
	— FLOOR-MOUNTED DUPLEX RECEPTACLE AND DATA CONNECTION.	L	— FIRE ALARM SYSTEM BELL/STROBE LIGHT AT 80" AFF 1 INDICATES 110 CANDELA INTENSITY.
	— DATA SYSTEM JACK, SINGLE GANG BOX AT 18" AFF WITH 1" CONDUIT TO ABOVE NEAREST ACCESSIBLE CEILING; SUBSCRIPTED NUMBER MOUNTING HEIGHT AFF	TS	— SPRINKLER SYSTEM TAMPER SWITCH
	— TELEPHONE SYSTEM VOICE JACK, SINGLE GANG BOX AT 18" AFF WITH 1" CONDUIT TO ABOVE NEAREST ACCESSIBLE CEILING; SUBSCRIPTED NUMBER INDICATES MOUNTING HEIGHT AFF	FS	— SPRINKLER SYSTEM FLOW SWITCH
	— COMBINATION VOICE AND DATA JACK, 1-GANG BOX AT 18" AFF WITH 1" CONDUIT TO ABOVE NEAREST ACCESSIBLE CEILING; SUBSCRIPTED NUMBER INDICATES MOUNTING HEIGHT AFF	PS	— SPRINKLER SYSTEM PRESSURE SWITCH
	— DATA SYSTEM FIBER OPTIC JACK, SINGLE GANG BOX AT 18" AFF WITH 1" CONDUIT TO ABOVE NEAREST ACCESSIBLE CEILING; SUBSCRIPTED NUMBER MOUNTING HEIGHT AFF	CS	— CLOCK SYSTEM SINGLE RECEPTACLE, NEMA 5-15R AT 80" ABOVE FINISHED FLOOR UNO.
	— INMATE PHONE, VOICE AND DATA JACK, 1-GANG BOX AT 48" AFF WITH 1" CONDUIT TO ABOVE NEAREST ACCESSIBLE CEILING; SUBSCRIPTED NUMBER INDICATES MOUNTING HEIGHT AFF	CS	— SOUND SYSTEM DEVICE, SEE SOUND SYSTEM DEVICE SCHEDULE ON DRAWINGS.
	— WALL PHONE, VOICE AND DATA JACK, 1-GANG BOX AT 48" AFF WITH 1" CONDUIT TO ABOVE NEAREST ACCESSIBLE CEILING; SUBSCRIPTED NUMBER INDICATES MOUNTING HEIGHT AFF	CS	— SOUND SYSTEM SPEAKER; CEILING-MOUNTED 2-GANG, 4" DEEP BOX WITH 1" CONDUIT TO ABOVE NEAREST ACCESSIBLE CEILING
	— REMOTE DOOR UNLOCK PUSH BUTTON	CS	— SOUND SYSTEM SPEAKER; CEILING-MOUNTED 2-GANG, 4" DEEP BOX WITH 1" CONDUIT TO ABOVE NEAREST ACCESSIBLE CEILING AND ADJACENT NEMA 5-20R DUPLEX RECEPTACLE.
	— CEILING MOUNTED WIRELESS WIFI ANTENNA	D	— DUCT SMOKE DETECTOR
	— OCCUPANCY SENSOR "SWITCH PACK" OR "POWER PACK" REFER TO DETAIL 8 ON SHEET E3	D	— SECURITY CAMERA
	— CONTROLLED DOOR	M	— MOTOR SYMBOL; THE NUMBER INSIDE INDICATES HP.

**ELECTRICAL CONVENTIONS**

(ALL CONVENTIONS MAY NOT APPEAR ON DRAWINGS.)

GENERAL NOTES APPLY TO ELECTRICAL DRAWING SET.  
DRAWING NOTES APPLY TO DRAWING ON WHICH NOTE APPEARS.  
SYMBOL NOTES APPLY TO DRAWING ON WHICH AND WHERE SYMBOL APPEARS.  
WIRE SIZES ARE INDICATED BY AMERICAN WIRE GAGE OR CIRCULAR MILS.

LB-3.5 — PANELBOARD, SWITCHBOARD OR MOTOR CONTROL CENTER DESIGNATION; ARROWHEADS INDICATE NUMBER OF BRANCH CIRCUITS  
— BRANCH CIRCUIT HOMERUN TO PANELBOARD, SWITCHBOARD OR MOTOR CONTROL CENTER; ARROWHEADS INDICATE NUMBER OF BRANCH CIRCUITS  
— CENTER LINE

**TYPICAL LIGHTING NOTATIONS SHOWN ON LIGHTING PLAN:**

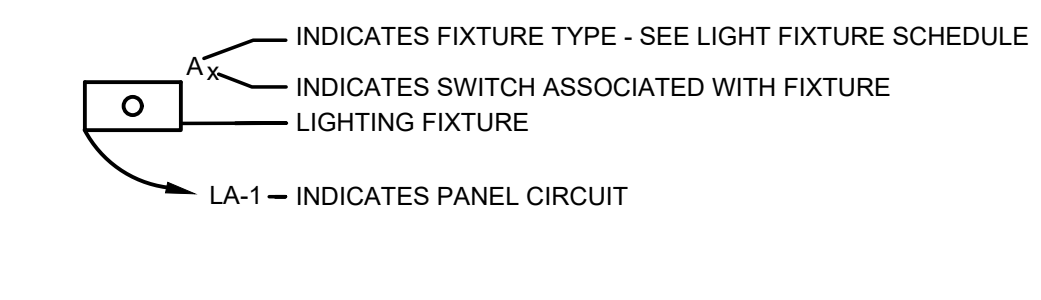

**TYPICAL POWER NOTATIONS SHOWN ON POWER PLAN:**

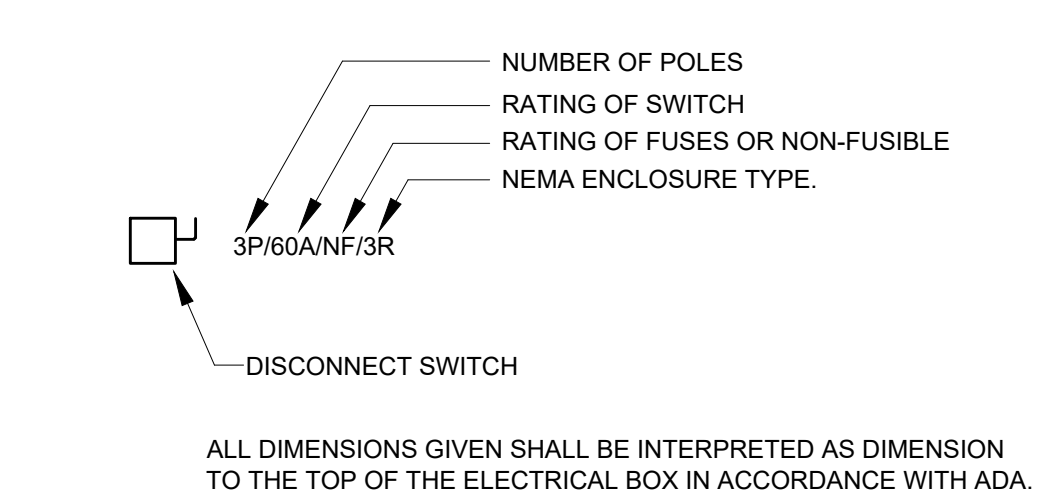

**DRAWING SYMBOLS**

(ALL SYMBOLS MAY NOT APPEAR ON DRAWINGS.)

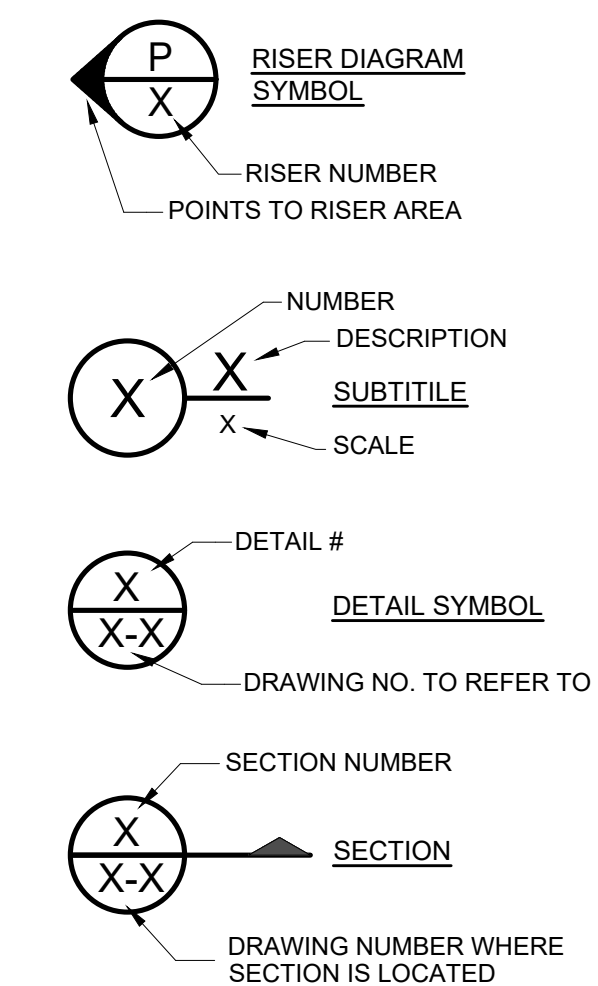

Texas Registered Firm No. F-7489  
500 North Central Expressway, Suite 310  
Ft. Worth, TX 76102  
Email: mlaberge@mdeng.com  
Project Number: 17939

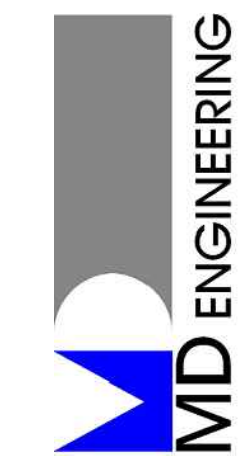

Collin County Justice Center  
Upgrade Pneumatic to Electronic Actuators  
4300 Community Ave. McKinney, Texas 75071

Revisions:  
DATE DESCRIPTION

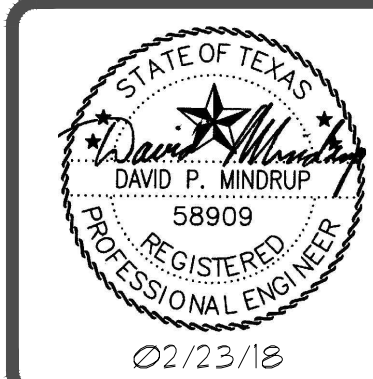

ELECTRICAL  
LEGEND

Project No.  
**17939**

Sheet No.  
**E0.0**

**POWER TO CONTROL DAMPER SCHEDULE - AREA 'A' (EXISTING)**

DESIG.	LOCATION	ASSOC. EQUIP.	VOLTS/PH	VA	WIRE & CONDUIT	TERMINATION	120V HEAD-IN EQUIP. SOURCE CIRCUIT	VOLTS/PH	LOCATION	WIRE & CONDUIT	TERMINATION
2A-AD-1	AREA A, LEVEL 2, MECH A200	HD-2A1	24/1	11	#16, 1/2" C.	DIRECT	E2BL-29	120/1	AREA A, LEVEL 2, MECH A200	#10, #10G, 3/4" C.	DIRECT
2A-AD-2	AREA A, LEVEL 2, MECH A200	AHU-1	24/1	11	#16, 1/2" C.	DIRECT					
2A-AD-3	AREA A, LEVEL 2, MECH A200	AHU-1	24/1	11	#16, 1/2" C.	DIRECT					
1A-AD-4	AREA A, LEVEL 1, RM 1220	HD-1A1	24/1	11	#16, 1/2" C.	DIRECT					
2A-SD-1	AREA A, LEVEL 2, MECH A200	AHU-1	24/1	15	#16, 1/2" C.	DIRECT					
2A-SD-2	AREA A, LEVEL 2, MECH A200	AHU-1	24/1	5	#16, 1/2" C.	DIRECT					
2A-SD-3	AREA A, LEVEL 2, MECH A200	AHU-1	24/1	15	#16, 1/2" C.	DIRECT					
2A-SD-4	AREA A, LEVEL 2, MECH A200	AHU-1	24/1	15	#16, 1/2" C.	DIRECT					
2A-SD-5	AREA A, LEVEL 2, MECH A200	AHU-1	24/1	24	#16, 1/2" C.	DIRECT					
2A-SD-6	AREA A, LEVEL 2, MECH A200	AHU-1	24/1	5	#16, 1/2" C.	DIRECT					
2A-SD-7	AREA A, LEVEL 2, MECH A200	AHU-1	24/1	5	#16, 1/2" C.	DIRECT					
2A-SD-8	AREA A, LEVEL 2, MECH A200	AHU-1	24/1	5	#16, 1/2" C.	DIRECT					
2A-SD-9	AREA A, LEVEL 2, MECH A200	AHU-1	24/1	5	#16, 1/2" C.	DIRECT					
2A-SD-10	AREA A, LEVEL 2, RM 2000A	AHU-1	24/1	5	#16, 1/2" C.	DIRECT					
2A-SD-11	AREA A, LEVEL 2, RM 2000A	AHU-1	24/1	5	#16, 1/2" C.	DIRECT					
2A-SD-12	AREA A, LEVEL 2, RM 2000A	AHU-1	24/1	5	#16, 1/2" C.	DIRECT					
1A-SD-13	AREA A, LEVEL 1, RM A1204	AHU-1	24/1	5	#16, 1/2" C.	DIRECT					
1A-SD-14	AREA A, LEVEL 1, RM A1204	AHU-1	24/1	5	#16, 1/2" C.	DIRECT					
1A-SD-15	AREA A, LEVEL 1, RM A1204	EF-1A3	24/1	5	#16, 1/2" C.	DIRECT					
1A-SD-16	AREA A, LEVEL 1, RM A1204	EF-1A3	24/1	5	#16, 1/2" C.	DIRECT					
1A-SD-17	AREA A, LEVEL 1, RM A1204	AHU-1	24/1	5	#16, 1/2" C.	DIRECT					
1A-SD-18	AREA A, LEVEL 1, RM A1208	AHU-1	24/1	5	#16, 1/2" C.	DIRECT					
1A-SD-19	AREA A, LEVEL 1, RM A1208	AHU-1	24/1	5	#16, 1/2" C.	DIRECT					
1A-SD-20	AREA A, LEVEL 1, RM A1209	AHU-1	24/1	5	#16, 1/2" C.	DIRECT					
2A-SD-22	AREA A, LEVEL 2, CORR.	AHU-2	24/1	5	#16, 1/2" C.	DIRECT					
ACTUATOR SUM = 208											

**CONTROL DAMPER SCHEDULE - AREA 'C' (EXISTING)**

DESIG.	LOCATION	ASSOC. EQUIP.	VOLTS/PH	VA	WIRE & CONDUIT	TERMINATION	120V HEAD-IN EQUIP. SOURCE CIRCUIT	VOLTS/PH	LOCATION	WIRE & CONDUIT	TERMINATION
2C-AD-1	AREA C, LEVEL 2, MECH C2001	HD-2C1	24/1	10	#16, 1/2" C.	DIRECT	E2BL-35	120/1	AREA C, LEVEL 2, MECH C2001	#10, #10G, 3/4" C.	DIRECT
2C-AD-2	AREA C, LEVEL 2, MECH C2001	AHU-2	24/1	10	#16, 1/2" C.	DIRECT					
2C-AD-3	AREA C, LEVEL 2, MECH C2001	RF-2C1	24/1	10	#16, 1/2" C.	DIRECT					
2C-SD-1	AREA C, LEVEL 2, MECH C2001	AHU-6	24/1	24	#16, 1/2" C.	DIRECT					
2C-SD-2	AREA C, LEVEL 2, MECH C2001	AHU-6	24/1	15	#16, 1/2" C.	DIRECT					
2C-SD-3	AREA C, LEVEL 2, MECH C2001	AHU-5	24/1	24	#16, 1/2" C.	DIRECT					
2C-SD-4	AREA C, LEVEL 2, MECH C2001	AHU-5	24/1	5	#16, 1/2" C.	DIRECT					
2C-SD-5	AREA C, LEVEL 2, MECH C2001	AHU-5	24/1	15	#16, 1/2" C.	DIRECT					
2C-SD-6	AREA C, LEVEL 2, MECH C2001	AHU-5	24/1	15	#16, 1/2" C.	DIRECT					
2C-SD-7	AREA C, LEVEL 2, MECH C2001	AHU-5	24/1	15	#16, 1/2" C.	DIRECT					
2C-SD-8	AREA C, LEVEL 2, MECH C2001	MAU-2G1	24/1	5	#16, 1/2" C.	DIRECT					
2C-SD-9	AREA C, LEVEL 2, C2001 CORR	AHU-6	24/1	5	#16, 1/2" C.	DIRECT					
2C-SD-10	AREA C, LEVEL 2, C2001 CORR	AHU-6	24/1	5	#16, 1/2" C.	DIRECT					
2C-SD-11	AREA C, LEVEL 2, C2001 CORR	AHU-6	24/1	5	#16, 1/2" C.	DIRECT					
1C-SD-12	AREA C, LEVEL 2, C2002 CORR	AHU-4	24/1	5	#16, 1/2" C.	DIRECT					
1C-SD-13	AREA C, LEVEL 1, RM B1412	AHU-4	24/1	15	#16, 1/2" C.	DIRECT					
1C-SD-14	AREA C, LEVEL 1, RM C1503	AHU-5	24/1	5	#16, 1/2" C.	DIRECT					
1C-SD-15	AREA C, LEVEL 1, RM C1500	AHU-5	24/1	5	#16, 1/2" C.	DIRECT					
ACTUATOR SUM = 193											

**CONTROL DAMPER SCHEDULE - AREA 'E' (EXISTING)**

DESIG.	LOCATION	ASSOC. EQUIP.	VOLTS/PH	VA	WIRE & CONDUIT	TERMINATION	120V HEAD-IN EQUIP. SOURCE CIRCUIT	VOLTS/PH	LOCATION	WIRE & CONDUIT	TERMINATION
2E-AD-1	AREA E, LEVEL 2, MECH E2001	HD-2E1	24/1	10	#16, 1/2" C.	DIRECT	1E1L-73	120/1	AREA E, LEVEL 2, MECH E2001	#10, #10G, 3/4" C.	DIRECT
2E-AD-2	AREA E, LEVEL 2, MECH E2001	AHU-8	24/1	10	#16, 1/2" C.	DIRECT					
2E-AD-3	AREA E, LEVEL 2, MECH E2001	AHU-8	24/1	10	#16, 1/2" C.	DIRECT					
2E-SD-1	AREA E, LEVEL 2, MECH E2001	AHU-7	24/1	24	#16, 1/2" C.	DIRECT					
2E-SD-2	AREA E, LEVEL 2, MECH E2001	AHU-7	24/1	24	#16, 1/2" C.	DIRECT					
2E-SD-3	AREA E, LEVEL 2, MECH E2001	AHU-7	24/1	15	#16, 1/2" C.	DIRECT					
2E-SD-4	AREA E, LEVEL 2, MECH E2001	AHU-8	24/1	24	#16, 1/2" C.	DIRECT					
2E-SD-5	AREA E, LEVEL 2, MECH E2001	EF-2E1	24/1	5	#16, 1/2" C.	DIRECT					
2E-SD-6	AREA E, LEVEL 2, MECH E2001	AHU-8	24/1	5	#16, 1/2" C.	DIRECT					
2E-SD-7	AREA E, LEVEL 2, MECH E2001	AHU-8	24/1	15	#16, 1/2" C.	DIRECT					
2E-SD-8	AREA E, LEVEL 2, MECH E2001	AHU-8	24/1	5	#16, 1/2" C.	DIRECT					
2E-SD-9	AREA E, LEVEL 2, MECH E2001	AHU-8	24/1	5	#16, 1/2" C.	DIRECT					
2E-SD-10	AREA E, LEVEL 2, MECH E2001	AHU-8	24/1	15	#16, 1/2" C.	DIRECT					
2E-SD-11	AREA E, LEVEL 2, MECH E2001	RF-2E1	24/1	24	#16, 1/2" C.	DIRECT					
2E-SD-12	AREA E, LEVEL 2, MECH E2001	AHU-7	24/1	24	#16, 1/2" C.	DIRECT					
2E-SD-13	AREA E, LEVEL 2, MECH E2001	AHU-7	24/1	24	#16, 1/2" C.	DIRECT					
2E-SD-14	AREA E, LEVEL 2, MECH E2001	AHU-7	24/1	24	#16, 1/2" C.	DIRECT					
2E-SD-15	AREA E, LEVEL 2, MECH E2001	AHU-7	24/1	24	#16, 1/2" C.	DIRECT					
1E-SD-16	AREA E, LEVEL 1, RM D1613 CHAS	AHU-8	24/1	5	#16, 1/2" C.	DIRECT	1E1A-36	120/1	AREA E, LEVEL 1, RM D1613 CHAS	#10, #10G, 3/4" C.	DIRECT
1E-SD-17	AREA E, LEVEL 1, RM D1613 CHAS	AHU-8	24/1	15	#16, 1/2" C.	DIRECT					
1E-SD-18	AREA E, LEVEL 1, RM D1613 CHAS	AHU-8	24/1	5	#16, 1/2" C.	DIRECT					
1E-SD-19	AREA E, LEVEL 1, RM D1613 CHAS	AHU-8	24/1	5	#16, 1/2" C.	DIRECT					
1E-SD-20	AREA E, LEVEL 1, RM D1613 CHAS	AHU-8	24/1	15	#16, 1/2" C.	DIRECT					
1E-SD-21	AREA E, LEVEL 1, RM D1613 CHAS	RF-2E1	24/1	24	#16, 1/2" C.	DIRECT					
1E-SD-22	AREA E, LEVEL 1, RM D1613 CHAS	EF-2E1	24/1	5	#16, 1/2" C.	DIRECT					
ACTUATOR SUM = 361											

**CONTROL DAMPER SCHEDULE - AREA 'B' (EXISTING)**

DESIG.	LOCATION	ASSOC. EQUIP.	VOLTS/PH	VA	WIRE & CONDUIT	TERMINATION	120V HEAD-IN EQUIP. SOURCE	VOLTS/PH	LOCATION	WIRE & CONDUIT	TERMINATION
2B-AD-1	AREA B, LEVEL 2, MECH B2001	AHU-3-4	24/1	10	#16, 1/2" C.	DIRECT	E2BL-33	120/1	AREA B, LEVEL 2, MECH B2001	#10, #10G, 3/4" C.	DIRECT
2B-AD-2	AREA B, LEVEL 2, MECH B2001	AHU-3-4	24/1	10	#16, 1/2" C.	DIRECT					
2B-AD-3	AREA B, LEVEL 2, MECH B2001	AHU-3-4	24/1	10	#16, 1/2" C.	DIRECT					
1B-AD-4	AREA B, LEVEL 1, RM B1307 N	SF-1B1	24/1	10	#16, 1/2" C.	DIRECT					
1B-AD-5	AREA B, LEVEL 1, RM B1307 NC	EF-1B8	24/1	10	#16, 1/2" C.	DIRECT					
1B-AD-6	AREA B, LEVEL 1, RM B1307 SC	EF-1B9	24/1	10	#16, 1/2" C.	DIRECT					
1B-AD-7	AREA B, LEVEL 1, RM B1307 S	SF-1B10	24/1	10	#16, 1/2" C.	DIRECT					
0B-AD-8	AREA B, LEVEL LL, MECH B0165	AHU-2	24/1	10	#16, 1/2" C.	DIRECT	E2BL-35	120/1	AREA B, LEVEL LL, MECH B0165	#10, #10G, 3/4" C.	DIRECT
0B-AD-9	AREA B, LEVEL LL, MECH B0165	AHU-2	24/1	10	#16, 1/2" C.	DIRECT					
0B-AD-10	AREA B, LEVEL LL, MECH B0165	EF-0B4	24/1	10	#16, 1/2" C.	DIRECT					
0B-AD-11	AREA B, LEVEL LL, MECH B0165	EF-0B3	24/1	10	#16, 1/2" C.	DIRECT					
0B-AD-12	AREA B, LEVEL LL, MECH B0151	AHU-2	24/1	10	#16, 1/2" C.	DIRECT	E2BL-35	120/1	AREA B, LEVEL LL, MECH B0151	#10, #10G, 3/4" C.	DIRECT
0B-AD-13	AREA B, LEVEL LL, MECH B0133	AHU-2	24/1	10	#16, 1/2" C.	DIRECT	E2BL-35	120/1	AREA B, LEVEL LL, MECH B0133	#10, #10G, 3/4" C.	DIRECT
0B-AD-14	AREA B, LEVEL LL, MECH B0110	AHU-2	24/1	10	#16, 1/2" C.	DIRECT	E2BL-35	120/1	AREA B, LEVEL LL, MECH B0110	#10, #10G, 3/4" C.	DIRECT
0B-AD-15	AREA B, LEVEL LL, MECH B0151	EF-0B5	24/1	10	#16, 1/2" C.	DIRECT	E2BL-35	120/1	AREA B, LEVEL LL, MECH B0151	#10, #10G, 3/4" C.	DIRECT
1B-SD-1	AREA B, LEVEL 1, RM B1115	EF-1B	24/1	5	#16, 1/2" C.	DIRECT					
1B-SD-2	AREA B, LEVEL 1, RM B1115	AHU-4	24/1	5	#16, 1/2" C.	DIRECT					
1B-SD-3	AREA B, LEVEL 1, RM B1103	AHU-4	24/1	5	#16, 1/2" C.	DIRECT					
1B-SD-4	AREA B, LEVEL 1, RM B1103	AHU-4	24/1	5	#16, 1/2" C.	DIRECT					
1B-SD-5	AREA B, LEVEL 1, RM B1109	AHU-4	24/1	5	#16, 1/2" C.	DIRECT					
1B-SD-6	AREA B, LEVEL 1, RM B1330	AHU-4	24/1	15	#16, 1/2" C.	DIRECT					
1B-SD-7	AREA B, LEVEL 1, RM B1330	AHU-3	24/1	5	#16, 1/2" C.	DIRECT					
1B-SD-8	AREA B, LEVEL 1, RM B1331	AHU-3	24/1	5	#16, 1/2" C.	DIRECT					
1B-SD-9	AREA B, LEVEL 1, RM B1332	AHU-3	24/1	5	#16, 1/2" C.	DIRECT					
1B-SD-10	AREA B, LEVEL 1, RM B1329	AHU-3	24/1	5	#16, 1/2" C.	DIRECT					
1B-SD-11	AREA B, LEVEL 1, RM B1329	AHU-3	24/1	5	#16, 1/2" C.	DIRECT					
1B-SD-12	AREA B, LEVEL 1, RM B1116	AHU-4	24/1	5	#16, 1/2" C.	DIRECT					
1B-SD-13	AREA B, LEVEL 1, RM B1116	AHU-4	24/1	5	#16, 1/2" C.	DIRECT					
1B-SD-14	AREA B, LEVEL 1, RM 1350	AHU-4	24/1	15	#16, 1/2" C.	DIRECT					
1B-SD-15	AREA B, LEVEL 1, RM 1350	AHU-4	24/1	24	#16, 1/2" C.	DIRECT					
1B-SD-16	AREA B, LEVEL 1, RM 1350	AHU-4	24/1	5	#16, 1/2" C.	DIRECT					
1B-SD-17	AREA B, LEVEL 1, RM 1336	EF-1B6	24/1	5	#16, 1/2" C.	DIRECT					
1B-SD-18	AREA B, LEVEL 1, RM 1336	AHU-3	24/1	5	#16, 1/2" C.	DIRECT					
1B-SD-19	AREA B, LEVEL 1, RM 1336	AHU-3	24/1	5	#16, 1/2" C.	DIRECT					
1B-SD-20	AREA B, LEVEL 1, RM 1336	AHU-3	24/1	5	#16, 1/2" C.	DIRECT					
1B-SD-21	AREA B, LEVEL 1, RM 1336	AHU-3	24/1	5	#16, 1/2" C.	DIRECT					
1B-SD-22	AREA B, LEVEL 1, RM 1307	AHU-4	24/1	24	#16, 1/2" C.	DIRECT					
1B-SD-23	AREA B, LEVEL 1, RM 1307	AHU-4	24/1	15	#16, 1/2" C.	DIRECT					
1B-SD-24	AREA B, LEVEL 1, RM 1343	AHU-4	24/1	15	#16, 1/2" C.	DIRECT					
1B-SD-25	AREA B, LEVEL 1, RM 1343	AHU-4	24/1	15	#16, 1/2" C.	DIRECT					
1B-SD-26	AREA B, LEVEL 1, RM	AHU-4	24/1	5	#16, 1/2" C.	DIRECT					
2B-SD-27	AREA B, LEVEL 2, MECH B 2001	AHU-4	24/1	15	#16, 1/2" C.	DIRECT					
2B-SD-28	AREA B, LEVEL 2, MECH B 2001	AHU-4									



**CONTROL DAMPER SCHEDULE - AREA 'G' (EXISTING)**

DESIG	LOCATION	ASSOC. EQUIP.	VOLTS/PH	VA	WIRE & CONDUIT	TERMINATION	120V HEADIN EQUIP. SOURCE CIRCUIT	VOLTS/PH	LOCATION	WIRE & CONDUIT	TERMINATION
2G-AD-1	AREA G, LEVEL 2, MECH G2002	AHU-12	24/1	10	#16, 1/2"C	DIRECT	E1GL-39	120/1	AREA G, LEVEL 2, MECH G2002	#10G, 3/4"C	DIRECT
2G-AD-2	AREA G, LEVEL 2, MECH G2002	AHU-12	24/1	10	#16, 1/2"C	DIRECT					
2G-AD-3	AREA G, LEVEL 2, MECH G2002	EF-2G28	24/1	10	#16, 1/2"C	DIRECT					
2G-AD-4	AREA G, LEVEL 2, MECH G2004	AHU-10,13	24/1	10	#16, 1/2"C	DIRECT	E1GL-39	120/1	AREA G, LEVEL 2, MECH G2004	#10G, 3/4"C	DIRECT
2G-AD-5	AREA G, LEVEL 2, MECH G2004	AHU-10,13	24/1	10	#16, 1/2"C	DIRECT					
2G-AD-6	AREA G, LEVEL 2, MECH G2004	EF-2G27	24/1	10	#16, 1/2"C	DIRECT					
2G-AD-7	AREA G, LEVEL 2, MECH G2004	AHU-10,15	24/1	10	#16, 1/2"C	DIRECT					
2G-AD-8	AREA G, LEVEL 2, MECH G2004	AHU-10,15	24/1	10	#16, 1/2"C	DIRECT					
2G-AD-9	AREA G, LEVEL 2, MECH G2004	EF-2G28	24/1	10	#16, 1/2"C	DIRECT					
2G-AD-10	AREA G, LEVEL 2, MECH G2005	AHU-14	24/1	10	#16, 1/2"C	DIRECT	E1GL-39	120/1	AREA G, LEVEL 2, MECH G2005	#10G, 3/4"C	DIRECT
2G-AD-11	AREA G, LEVEL 2, MECH G2005	AHU-14	24/1	10	#16, 1/2"C	DIRECT					
2G-AD-12	AREA G, LEVEL 2, MECH G2005	EF-2G29	24/1	10	#16, 1/2"C	DIRECT					
2G-AD-13	AREA G, LEVEL 2, MECH G2002	SF-2G10	24/1	10	#16, 1/2"C	DIRECT					
2G-AD-14	AREA G, LEVEL 1, NE DAY RM	SF-1G9	24/1	10	#16, 1/2"C	DIRECT					
2G-AD-15	AREA G, LEVEL 2, MECH G2004	AHU-10	24/1	10	#16, 1/2"C	DIRECT					
2G-AD-16	AREA G, LEVEL 2, MECH G2004	SF-2G18	24/1	10	#16, 1/2"C	DIRECT					
2G-AD-17	AREA G, LEVEL 2, MECH G2004	EF-1G2	24/1	10	#16, 1/2"C	DIRECT					
2G-AD-18	AREA G, LEVEL 2, MECH G2004	SF-2G8	24/1	10	#16, 1/2"C	DIRECT					
2G-AD-19	AREA G, LEVEL 1, SE DAY RM	SF-1G9	24/1	10	#16, 1/2"C	DIRECT					
2G-AD-20	AREA G, LEVEL 2, MECH G2004	SF-2G7	24/1	10	#16, 1/2"C	DIRECT					
2G-AD-21	AREA G, LEVEL 1, SW DAY RM	SF-1G2	24/1	10	#16, 1/2"C	DIRECT					
2G-AD-22	AREA G, LEVEL 2, MECH G2005	SF-2G10	24/1	10	#16, 1/2"C	DIRECT					
2G-AD-23	AREA G, LEVEL 1, NW DAY RM	SF-1G9	24/1	10	#16, 1/2"C	DIRECT					
2G-AD-24	AREA G, LEVEL 2, NE REC AREA	SF-2G15	24/1	10	#16, 1/2"C	DIRECT					
2G-AD-25	NOT USED										
2G-AD-26	AREA G, LEVEL 2, NE REC AREA	AHU-12	24/1	10	#16, 1/2"C	DIRECT					
2G-AD-27	AREA G, LEVEL 2, NE REC AREA	AHU-12	24/1	10	#16, 1/2"C	DIRECT					
2G-AD-28	AREA G, LEVEL 2, NE DAY RM	EF-2G3	24/1	10	#16, 1/2"C	DIRECT					
2G-AD-29	AREA G, LEVEL 2, NE DAY RM	EF-2G7	24/1	10	#16, 1/2"C	DIRECT					
2G-AD-30	AREA G, LEVEL 2, NE DAY RM	EF-2G3	24/1	10	#16, 1/2"C	DIRECT					
2G-AD-31	AREA G, LEVEL 2, NE DAY RM	SF-2G18	24/1	10	#16, 1/2"C	DIRECT					
2G-AD-32	AREA G, LEVEL 2, SE REC AREA	EF-2G2	24/1	10	#16, 1/2"C	DIRECT					
2G-AD-33	AREA G, LEVEL 2, SE REC AREA	AHU-13	24/1	10	#16, 1/2"C	DIRECT					
2G-AD-34	AREA G, LEVEL 2, SE DAY RM	EF-2G2	24/1	10	#16, 1/2"C	DIRECT					
2G-AD-35	AREA G, LEVEL 2, SE DAY RM	EF-2G8	24/1	10	#16, 1/2"C	DIRECT					
2G-AD-36	AREA G, LEVEL 2, SE DAY RM	EF-2G2	24/1	10	#16, 1/2"C	DIRECT					
2G-AD-37	AREA G, LEVEL 2, SE DAY RM	SF-2G12	24/1	10	#16, 1/2"C	DIRECT					
2G-AD-38	AREA G, LEVEL 2, SW REC AREA	EF-2G1	24/1	10	#16, 1/2"C	DIRECT					
2G-AD-39	AREA G, LEVEL 2, SW REC AREA	AHU-15	24/1	10	#16, 1/2"C	DIRECT					
2G-AD-40	AREA G, LEVEL 2, SW DAY RM	EF-2G1	24/1	10	#16, 1/2"C	DIRECT					
2G-AD-41	AREA G, LEVEL 2, SW DAY RM	EF-2G5	24/1	10	#16, 1/2"C	DIRECT					
2G-AD-42	AREA G, LEVEL 2, SW DAY RM	EF-2G1	24/1	10	#16, 1/2"C	DIRECT					
2G-AD-43	AREA G, LEVEL 2, SW DAY RM	SF-2G11	24/1	10	#16, 1/2"C	DIRECT					
2G-AD-44	AREA G, LEVEL 2, NW REC AREA	EF-2G4	24/1	10	#16, 1/2"C	DIRECT					
2G-AD-45	AREA G, LEVEL 2, NW REC AREA	AHU-14	24/1	10	#16, 1/2"C	DIRECT					
2G-AD-46	AREA G, LEVEL 2, NW DAY RM	EF-2G4	24/1	10	#16, 1/2"C	DIRECT					
2G-AD-47	AREA G, LEVEL 2, NW DAY RM	EF-2G8	24/1	10	#16, 1/2"C	DIRECT					
2G-AD-48	AREA G, LEVEL 2, NW DAY RM	EF-2G4	24/1	10	#16, 1/2"C	DIRECT					
2G-AD-49	AREA G, LEVEL 2, NW DAY RM	SF-2G18	24/1	10	#16, 1/2"C	DIRECT					
1G-AD-50	AREA G, LEVEL 1, CORE AREA	EF-1G2	24/1	10	#16, 1/2"C	DIRECT					
1G-AD-51	AREA G, LEVEL 1, CORE AREA	EF-1G2	24/1	10	#16, 1/2"C	DIRECT					
1G-AD-52	AREA G, LEVEL 1, CORE AREA	EF-1G2	24/1	10	#16, 1/2"C	DIRECT					
1G-AD-53	AREA G, LEVEL 1, CORE AREA	EF-1G2	24/1	10	#16, 1/2"C	DIRECT					
1G-AD-54	AREA G, LEVEL 1, CORE AREA	EF-1G2	24/1	10	#16, 1/2"C	DIRECT					
1G-AD-55	AREA G, LEVEL 1, CORE AREA	EF-1G2	24/1	10	#16, 1/2"C	DIRECT					
1G-AD-56	AREA G, LEVEL 1, CORE AREA	EF-1G2	24/1	10	#16, 1/2"C	DIRECT					
1G-AD-57	AREA G, LEVEL 1, CORE AREA	EF-1G2	24/1	10	#16, 1/2"C	DIRECT					
1G-AD-58	AREA G, LEVEL 1, NE DAY RM	SF-1G7	24/1	10	#16, 1/2"C	DIRECT					
1G-AD-59	AREA G, LEVEL 1, NE DAY RM	SF-1G7	24/1	10	#16, 1/2"C	DIRECT					
1G-AD-60	AREA G, LEVEL 1, NE DAY RM	SF-1G11	24/1	10	#16, 1/2"C	DIRECT					
1G-AD-61	AREA G, LEVEL 1, NE DAY RM	SF-1G11	24/1	10	#16, 1/2"C	DIRECT					
1G-AD-62	AREA G, LEVEL 1, SE DAY RM	SF-1G1	24/1	10	#16, 1/2"C	DIRECT					
1G-AD-63	AREA G, LEVEL 1, SE DAY RM	SF-1G1	24/1	10	#16, 1/2"C	DIRECT					
1G-AD-64	AREA G, LEVEL 1, SE DAY RM	SF-1G4	24/1	10	#16, 1/2"C	DIRECT					
1G-AD-65	AREA G, LEVEL 1, SE DAY RM	SF-1G4	24/1	10	#16, 1/2"C	DIRECT					
1G-AD-66	AREA G, LEVEL 1, SW DAY RM	SF-1G8	24/1	10	#16, 1/2"C	DIRECT					
1G-AD-67	AREA G, LEVEL 1, SW DAY RM	SF-1G8	24/1	10	#16, 1/2"C	DIRECT					
1G-AD-68	AREA G, LEVEL 1, SW DAY RM	SF-1G1	24/1	10	#16, 1/2"C	DIRECT					
1G-AD-69	AREA G, LEVEL 1, SW DAY RM	SF-1G1	24/1	10	#16, 1/2"C	DIRECT					
1G-AD-70	AREA G, LEVEL 1, NW DAY RM	SF-1G10	24/1	10	#16, 1/2"C	DIRECT					
1G-AD-71	AREA G, LEVEL 1, NW DAY RM	SF-1G10	24/1	10	#16, 1/2"C	DIRECT					
1G-AD-72	AREA G, LEVEL 1, NW DAY RM	SF-1G8	24/1	10	#16, 1/2"C	DIRECT					
1G-AD-73	AREA G, LEVEL 1, NW DAY RM	SF-1G8	24/1	10	#16, 1/2"C	DIRECT					
1G-AD-74	AREA G, LEVEL 1, CORE AREA	SF-2G18	24/1	10	#16, 1/2"C	DIRECT					
2G-SD-1	AREA G, LEVEL 2, MECH G2002	AHU-10	24/1	5	#16, 1/2"C	DIRECT					
2G-SD-2	AREA G, LEVEL 2, MECH G2002	AHU-12	24/1	24	#16, 1/2"C	DIRECT					
2G-SD-3	AREA G, LEVEL 2, MECH G2004	AHU-10	24/1	35	#16, 1/2"C	DIRECT					
2G-SD-4	AREA G, LEVEL 2, MECH G2004	AHU-13	24/1	24	#16, 1/2"C	DIRECT					
2G-SD-5	AREA G, LEVEL 2, MECH G2004	AHU-15	24/1	24	#16, 1/2"C	DIRECT					
2G-SD-6	AREA G, LEVEL 2, MECH G2005	AHU-14	24/1	24	#16, 1/2"C	DIRECT					
2G-SD-7	AREA G, LEVEL 2, MECH G2004	EF-1G1	24/1	15	#16, 1/2"C	DIRECT					
2G-SD-8	AREA G, LEVEL 2, MECH G2004	EF-1G2	24/1	24	#16, 1/2"C	DIRECT					
2G-SD-9	AREA G, LEVEL 2, MECH G2004	SF-2G18	24/1	24	#16, 1/2"C	DIRECT					

**CONTROL DAMPER SCHEDULE - AREA 'H' (EXISTING)**

DESIG	LOCATION	ASSOC. EQUIP.	VOLTS/PH	VA	WIRE & CONDUIT	TERMINATION	120V HEADIN EQUIP. SOURCE CIRCUIT	VOLTS/PH	LOCATION	WIRE & CONDUIT	TERMINATION
2HAD-1	AREA H, LEVEL 2, MECH H2002	AHU-16	24/1	10	#10, 1/2"C	DIRECT	E1HL-35	120/1	AREA H, LEVEL 2, MECH H2002	#10, #10G, 3/4"C	DIRECT
2HAD-2	AREA H, LEVEL 2, MECH H2002	AHU-16	24/1	10	#10, 1/2"C	DIRECT					
2HAD-3	AREA H, LEVEL 2, MECH H2002	EF-2H21	24/1	10	#10, 1/2"C	DIRECT					
2HAD-4	AREA H, LEVEL 2, MECH H2004	AHU-11,17	24/1	10	#10, 1/2"C	DIRECT	E1HL-35	120/1	AREA H, LEVEL 2, MECH H2004	#10, #10G, 3/4"C	DIRECT
2HAD-5	AREA H, LEVEL 2, MECH H2004	AHU-11,17	24/1	10	#10, 1/2"C	DIRECT					
2HAD-6	AREA H, LEVEL 2, MECH H2004	EF-2H28	24/1	10	#10, 1/2"C	DIRECT					
2HAD-7	AREA H, LEVEL 2, MECH H2004	AHU-11,19	24/1	10	#10, 1/2"C	DIRECT					
2HAD-8	AREA H, LEVEL 2, MECH H2004	AHU-11,19	24/1	10	#10, 1/2"C	DIRECT					
2HAD-9	AREA H, LEVEL 2, MECH H2004	EF-2H29	24/1	10	#10, 1/2"C	DIRECT					
2HAD-10	AREA H, LEVEL 2, MECH H2005	AHU-18	24/1	10	#10, 1/2"C	DIRECT					
2HAD-11	AREA H, LEVEL 2, MECH H2005	AHU-18	24/1	10	#10, 1/2"C	DIRECT					
2HAD-12	AREA H, LEVEL 2, MECH H2005	EF-2H30	24/1	10	#10, 1/2"C	DIRECT					
2HAD-13	AREA H, LEVEL 2, MECH H2002	SF-2H10	24/1	10	#10, 1/2"C	DIRECT					
2HAD-14	AREA H, LEVEL 2, NE DAY RM	SF-1H9	24/1	10	#10, 1/2"C	DIRECT					
2HAD-15	AREA H, LEVEL 2, MECH H2004	AHU-11	24/1	10	#10, 1/2"C	DIRECT					
2HAD-16	AREA H, LEVEL 2, MECH H2004	SF-2H18	24/1	10	#10, 1/2"C	DIRECT					
2HAD-17	AREA H, LEVEL 2, MECH H2004	EF-1H2	24/1	10	#10, 1/2"C	DIRECT					
2HAD-18	AREA H, LEVEL 2, MECH H2004	SF-2H8	24/1	10	#10, 1/2"C	DIRECT					
2HAD-19	AREA H, LEVEL 1, SE DAY RM	SF-1H9	24/1	10	#10, 1/2"C	DIRECT					
2HAD-20	AREA H, LEVEL 2, MECH H2004	SF-2H7	24/1	10	#10, 1/2"C	DIRECT					
2HAD-21	AREA H, LEVEL 1, SW DAY RM	SF-1H2	24/1	10	#10, 1/2"C	DIRECT					
2HAD-22	AREA H, LEVEL 1, CONTROL RM	SF-1H14	24/1	10	#10, 1/2"C	DIRECT					
2HAD-23	AREA H, LEVEL 1, NW DAY RM	SF-1H10	24/1	10	#10, 1/2"C	DIRECT					
2HAD-24	AREA H, LEVEL 2, NE REC AREA	EF-2H7	24/1	10	#10, 1/2"C	DIRECT					
2HAD-25	AREA H, LEVEL 2, NE REC AREA	AHU-16	24/1	10	#10, 1/2"C	DIRECT					
2HAD-26	AREA H, LEVEL 2, NW REC AREA	AHU-18	24/1	10	#10, 1/2"C	DIRECT					
2HAD-27	AREA H, LEVEL 2, NW REC AREA	AHU-18	24/1	10	#10, 1/2"C	DIRECT					
2HAD-28	AREA H, LEVEL 2, NE DAY RM	EF-2H7	24/1	10	#10, 1/2"C	DIRECT					
2HAD-29	AREA H, LEVEL 2, NE DAY RM	EF-2H3	24/1	10	#10, 1/2"C	DIRECT					
2HAD-30	AREA H, LEVEL 2, NE DAY RM	EF-2H7	24/1	10	#10, 1/2"C	DIRECT					
2HAD-31	AREA H, LEVEL 2, NE DAY RM	SF-2H16	24/1	10	#10, 1/2"C	DIRECT					
2HAD-32	AREA H, LEVEL 2, SE REC AREA	EF-2H6	24/1	10	#10, 1/2"C	DIRECT					
2HAD-33	AREA H, LEVEL 2, SE REC AREA	AHU-17	24/1	10	#10, 1/2"C	DIRECT					
2HAD-34	AREA H, LEVEL 2, SE DAY RM	EF-2H6	24/1	10	#10, 1/2"C	DIRECT					
2HAD-35	AREA H, LEVEL 2, SE DAY RM	EF-2H2	24/1	10	#10, 1/2"C	DIRECT					
2HAD-36	AREA H, LEVEL 2, SE DAY RM	EF-2H6	24/1	10	#10, 1/2"C	DIRECT					
2HAD-37	AREA H, LEVEL 2, SE DAY RM	SF-2H12	24/1	10	#10, 1/2"C	DIRECT					
2HAD-38											