

Turner

Turner Construction Company
2001 N. Lamar, Suite 100
Dallas, TX 75202
Phone: (214) 721-8400
Fax: (214) 721-8493

7/5/11

Mr. Bill Burke
Collin County
4600 Community Ave.
McKinney, TX 75071

RE: **Collin County Courthouse Addition**
Owner Project #R0508003.00
Turner Project #1692600

SUBJ: PCO #109 – Additional Concrete at West Ramp Near Sally Port.

Dear Mr. Burke:

We have finalized the required quotations for PCO #109 – Additional Concrete at West Ramp Near Sally Port.

We have reviewed the scope of work and have verified that all extra work items are in compliance with our contract agreement. Attached is a detailed itemization of the extra costs. Total amount of this request is **Two Thousand dollars (\$2,000)**.

If you have any questions regarding this Change Order Request, please call me at your earliest convenience. This pricing is valid for (5) days, after which, we reserve the right to re-evaluate.

Please review and acknowledge your approval in the space below. Once approval is achieved, we will expect this PCO to be included in a forthcoming Change Order.

Best Regards,

J. Leos

John Leos

Approved by:

Collin County

Brian Nicodemus

PGAL

Date

7.12.11

Date

cc: Brad Harris & Sara Hoglund- Collin County
Brian Nicodemus- PGAL
Matt Nail & Kevin Karagias- TCCo

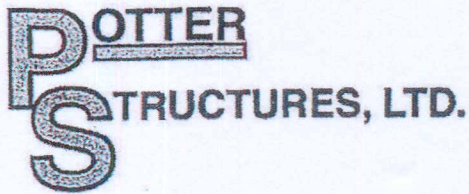

PCO #109

Tuesday, June 21, 2011

Mr. John Leos
Turner Construction Company
2100 Bloomdale Road
McKinney, TX 75071

RE: Potential Change Order # 029
Document Number 040
129 - Collin County Courthouse- 17-05-129

Dear Mr. Leos,

This letter is to provide official pricing of a potential project change as follows:

PCO Number: 029
Date: 21-Jun-11
Description: West ramp near Sally Port
Proposed Amt: \$1,758.00

RECEIVED 6/10/11 EMAIL FROM COLLIN COUNTY

This PCO is comprised of the following items:

Item Number	Description	Proposed Amount
001	Install an additional 250 sf of sidewalk near Sally Port. Please see attached for detailed breakout.	\$1,758.00

Total: \$1,758.00

Per the terms and conditions of our contract, we request an official Notice to Proceed to start this extra work. We also need a Change Order for this extra work. If you have any questions, please contact the undersigned at 214-630-2191 as soon as possible.

Respectfully,

Alan Dugger
Project Manager

Leos, John - (TEXAS)

From: Rausch, Evan - (TEXAS)
Sent: Monday, June 27, 2011 2:32 PM
To: Leos, John - (TEXAS)
Subject: FW: CCCA: Concrete Add and relocated two extra bollards

Evan Rausch | Assistant Superintendent
Turner Construction Company | 2001 North Lamar, Suite 100, Dallas, Texas 75202
972.468.8491 Direct | 214.604.9122 Cell | www.turnerconstruction.com

Turner



From: Brad Harris [mailto:bjharris@co.collin.tx.us]
Sent: Friday, June 10, 2011 10:15 AM
To: Rausch, Evan - (TEXAS)
Subject: CCCA: Concrete Add and relocated two extra bollards

The L1.0 drawing that shows where grass is scheduled to be installed.

I have pointed out the area that needs to have 4" concrete poured and the preferred location of the two extra bollards.

6/27/2011

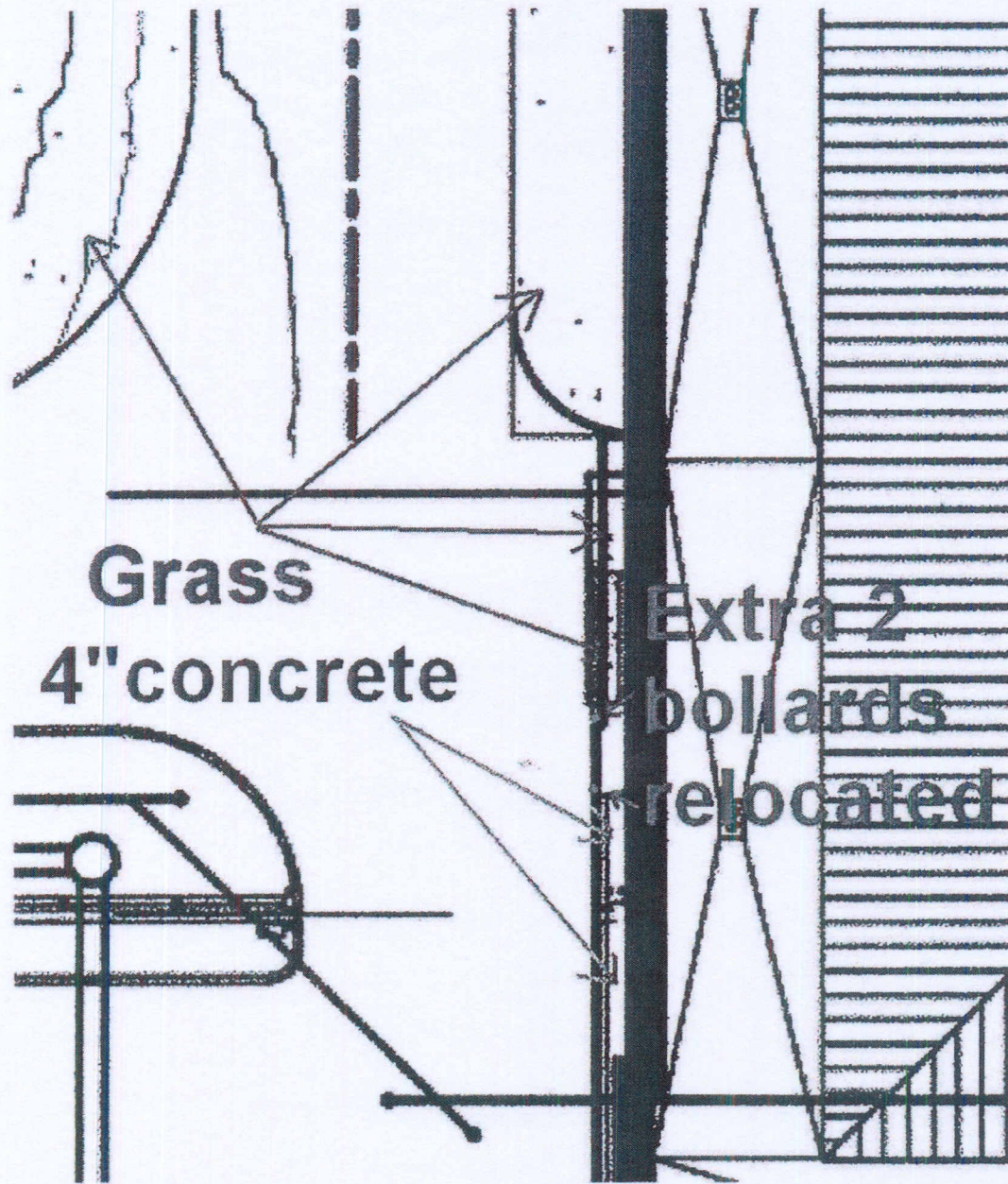

Let's see if we can get this worked out for concrete pricing.

Thanks,



Brad Harris | Building Project Coordinator
Collin County Construction and Projects
4600 Community Ave. McKinney, TX 75071
(o) 972-547-5492 | (m) 214-205-7322

6/27/2011

Bill Burke

From: Brian Nicodemus [BNicodemus@pgal.com]
Sent: Tuesday, July 12, 2011 3:55 PM
To: Brad Harris
Cc: Bill Burke; Sara Hoglund; David L. Andrews; Walter Bateman; Lisa Bunch
Subject: RE: CCCA: Signed PCOs

Brad,

I the following comments regarding the PCOs listed in your email below:

PCO 77R1 – PGAL understands that Collin County negotiated this change order with Turner Construction directly and is asking PGAL to sign the Turner Construction PCO letter as a formality. PGAL feels that this work should have been in the base bid per note on C4.02 “Contractor shall verify location of existing utilities prior to construction and notify engineer of any conflicts. This was confirmed in an email from Brad Harris on 4.18.11. Collin County was never made aware that the ongoing bollard locations would ultimately lead to additional costs and additional work.

PCO 98 – PGAL would like to make it very clear that this price for work listed as RFI 117 price is due to coordination errors by the Contractor. Firstly, RFI 117 was responded to in an attempt to assist Turner Construction with coordination field errors on 1.25.11. This PCO is dated 6.17.11. The Contract Documents clearly stipulate that pricing is to be sent in 7 days on an RFI response. This is a breach of Contract. Had PGAL and Collin County been aware of the cost implications, we simply could have had the improper restroom sleeve locations moved to the correct locations at cost to the Contractor. A negotiation in RFI 117 occurred. This negotiation said that we could keep all existing work intact if we made each corridor restroom match the layout of the DA restroom. That way we could allow proper ADA access to all restroom stalls. An email was sent by John Leos stating that all of these costs would be covered to allow the project to move forward. I feel that this would have cost Turner Construction more than the shown \$18,257.00 for this PCO had they had to core new holes, adjust for proper layout and time/labor lost on the critical path.

PCO102R1 – This price is within current regional pricing for this scope of work. This work is not needed for code compliance. I wanted to point out that we have dealt with clients who preferred to allow the tenant improve the space with wall coverings of this type. As requested, attached is this signed PCO.

PCO 105 – No comments.

PCO 106 – Turner Construction has deleted the J3 wall in the cafeteria without written direction. I assume that Collin County will be expecting a credit for this sf amount on the J3 walls when it is sent.

PCO 109 – PGAL has not been included in any negotiations directly with Turner Construction on this PCO. The last email conversations we were copied on focused on the comment from Brad Harris on 7 This PCO should be estimated at the \$4.00 a square foot as agreed in the Turner Construction contract. The line item for the concrete saw cutting and removal should be removed from this PCO because this is corrective work required because the nearby demolition damaged the concrete edge.

This PCO should be \$1000 plus the Turner Construction markup.

Brian Nicodemus
 Senior Associate



Alexandria
 [T] 703 836 0588 [F] 703 836 8027
 Austin
 [T] 512 236 1005 [F] 512 853 6126
 Boston
 [T] 617 350 8667 [F] 617 350 8669
 Houston
 [T] 713 622 1444 [F] 713 968 9333

Atlanta
 [T] 404 602 3800 [F] 404 602 3810
 Boca Raton
 [T] 561 988 4002 [F] 561 988 3002
 Dallas
 [T] 972 871 2225 [F] 972 871 2228
 Las Vegas
 [T] 702 435 4448 [F] 702 435 4470

7/18/2011

Los Angeles
[T] 310 645 3276 [F] 310 645 3026 <http://www.PGAL.com>

From: Brad Harris [mailto:bjharris@co.collin.tx.us]
Sent: Tuesday, July 12, 2011 7:45 AM
To: Brian Nicodemus
Cc: Bill Burke; Sara Hoglund; David L. Andrews; Walter Bateman; Lisa Bunch
Subject: CCCA: Signed PCOs

Brian,

Can I get you to sign CCCA PCOs #77 R, #98, #102, #105, #106 and #109?

We need these PCOs signed this morning for the Commissioners Court agenda deadline.

Thanks,

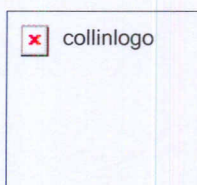

Brad Harris | Building Project Coordinator
Collin County Construction and Projects
4600 Community Ave. McKinney, TX 75071
(o) 972-547-5492 | (m) 214-205-7322
bjharris@co.collin.tx.us