



COLLIN COUNTY

ROADWAY STANDARDS

Draft August 29, 2020

Approved by the Collin County Commissioners Court on _____

Court Order Number _____

TABLE OF CONTENTS

1.01	INTRODUCTION	4
A.	Purpose.....	4
B.	Intent.....	4
1.02	DEFINITIONS	4
1.03	ROADWAY & PAVEMENT SELECTION	5
A.	Roadway Types.....	5
B.	Pavement Types.....	6
1.04	ROADWAY GEOMETRIC DESIGN	7
A.	Right of Way.....	7
B.	Standards for Typical Roadway Types	7
C.	Intersections.....	12
D.	Turn Lanes.....	14
E.	Driveways.....	15
F.	Sidewalks.....	16
G.	Roadway Layout.....	16
H.	Cul-de-sacs	16
1.05	PAVEMENT - GENERAL	17
A.	General.....	17
1.06	PAVEMENT - DESIGN	17
A.	Pavements for New Residential Roadways	17
B.	Pavements for New Collector Roadways.....	19
1.07	PAVEMENT - MATERIALS	21
A.	Subgrade	21
B.	Flexible Base.....	21
C.	Surface Treatments.....	21
D.	Hot-Mix Asphalt Concrete (HMAC).....	22
E.	Portland Cement Concrete.....	22
1.08	PAVEMENT - CONSTRUCTION	23
A.	Subgrade	23
B.	Flexible Base.....	25
C.	Surface Treatments.....	25
D.	Hot-Mix Asphalt Concrete (HMAC).....	26

E.	Portland Cement Concrete	26
1.09	PAVEMENT - TESTING, INSPECTION & ACCEPTANCE.....	26
A.	General.....	26
B.	Pre-Construction Submittals Required	26
C.	Certified Elevations	27
D.	Subgrade	28
E.	Flexible Base.....	29
F.	Surface Treatments	29
G.	Hot-Mix Asphalt Concrete (HMAC).....	29
H.	Portland Cement Concrete	29
1.10	MAINTENANCE.....	30
A.	Maintenance	30
B.	Patching	30
C.	Joint Repair	30
1.11	APPROVAL FOR COUNTY MAINTENANCE	30
A.	Acceptance of Roadways for County Maintenance.....	30
APPENDIX A	Pavement Patching Details.....	31

COLLIN COUNTY ROADWAY STANDARDS

1.01 INTRODUCTION

A. Purpose

Commissioners Court adopted the Collin County Roadway Standards to provide minimum standards and prevent substandard roadways in Collin County. These Standards are minimum requirements for design and construction of roadway facilities conducive to a superior quality of life and maintainability without imposing a burden to the taxpayers.

B. Intent

In the interpretation and application of the provisions of these regulations, it is the intention of the County that the principles, standards, and requirements provided for herein shall be minimum requirements for the construction of roadways in unincorporated Collin County. Where City, State, Federal, or other jurisdiction regulations are more restrictive, such other regulations shall control.

Commissioners Court reserves the right to amend any portion of this court order as deemed necessary and/or when required by changes in the law of Texas, state statutes or transportation codes.

1.02 DEFINITIONS

ALLEY – a minor public right of way or private roadway easement that is used primarily for vehicular services access to the back or sides of property otherwise abutting on a roadway.

COLLECTOR ROADWAY - a roadway serving one hundred fifty (150) lots or more, including those outside the subdivision (ie future phases or connected subdivisions). Collector Roadways provide connectivity between Residential Roadways and existing County Roadways or future Thoroughfares.

DEVELOPER - any person, partnership, firm association, corporation (or combination thereof), or any officer, agent, employee, servant or trustee thereof, who performs or participates in the performing of any act toward the development of a subdivision, within the intent, scope, and purview of these Standards.

DEVELOPMENT - all land modification activity, including the grading or construction of buildings, roadways, parking lots, and/or other impervious structures or surfaces.

DIRECTOR OF ENGINEERING - where used in these Standards, “Director of Engineering” shall mean the Collin County Director of Engineering and his/her authorized and/or appointed representatives.

ENGINEER – a person licensed under the provisions of the Texas Engineering Registration Act to practice the profession of engineering in the State of Texas.

RESIDENTIAL ROADWAY - a roadway serving less than one hundred fifty (150) lots, including those outside the subdivision (ie future phases or connected subdivisions).

Residential Roadways provide connectivity between residential driveways and Collector Roadways, existing County Roadways, or future Thoroughfares.

RIGHT OF WAY – a parcel of land that is occupied or intended to be occupied, by a roadway or alley. Where appropriate, “right of way” may include other facilities and/or utilities such as sidewalks; railroad crossings; and/or electrical, telecommunication, oil, gas, water, sanitary sewer and/or storm sewer facilities. The term “right of way” shall also include parkways and medians which are located outside of the actual pavement. The usage of the term “right of way” for land platting purposes shall mean that every public right of way hereafter established and shown on a final plat is to be separate and distinct from the lots or parcels adjoining such right of way and shall not be included within the dimensions or areas of such lots or parcels. The right of way is the distance between property lines measured at right angles to the centerline of the roadway or alley.

ROADWAY – a paved right of way (or easement), whether public or private and however designated, which provides vehicular access to adjacent land and/or connection to other roadways or highways.

RURAL - a subdivision having lots that are one (1) acre (no less than 43,560 square feet) or larger.

SURVEYOR – a person licensed under the provisions of the Texas Professional Land Surveying Practices Act to practice the profession of surveying in the State of Texas.

URBAN - a subdivision having lots that are less than one (1) acre (less than 43,560 square feet).

1.03 ROADWAY & PAVEMENT SELECTION

A. Roadway Types

Roadway types are based on number of lots and the size of lots using the roadway. This may be more than the number of lots in a subdivision, as may occur in future phases of development or when subdivisions are connected. The intent is to capture planned roadway usage, not predict use of a subdivision roadway as a bypass or cut-through. Standards are provided herein for the following roadway types:

1. RR - Rural Residential Roadway
2. UR - Urban Residential Roadway
3. RC - Rural Collector Roadway
4. UC - Urban Collector Roadway

Table 1.03-1 indicates the roadway types applicable to various configurations of lot number and lot size. See Section 1.04 for additional information for these roadway types.

Table 1.03-1 Roadway Types

	Lots 1.0 acre or larger	Lots less than 1.0 acre
Less than 150 lots	RR	UR
150 lots or more	RC	UC

B. Pavement Types

Pavement types are based on the number of lots and the size of lots using the roadway. This may be more than the number of lots in a subdivision, as may occur in future phases of development or when subdivisions are connected. The intent is to capture planned roadway usage, not predict use of a subdivision roadway as a bypass or cut-through. Standards are provided herein for the following pavement types:

1. AR – Asphalt Residential
2. CR – Concrete Residential

Table 1.03-2 indicates the pavement types applicable to various configurations of lot number and lot size. An alley is considered a Residential Roadway for purposes of pavement design. A Report of Geotechnical Investigation and Pavement Design sealed by an Engineer is required for Collector Roadways.

See Section 1.06 for additional information about pavement types.

Table 1.03-2 Pavement Types

	Lots 1.0 acre or larger	Lots less than 1.0 acre
Less than 150 lots	AR, CR	CR only
150 lots or more	Design by Geotechnical Engineer, AR minimum	Design by Geotechnical Engineer, CR minimum

1.04 ROADWAY GEOMETRIC DESIGN

A. Right of Way

1. Residential and Collector Roadways. Table 1.04-1 lists the right of way widths required for the roadway types defined in Section 1.03.

Table 1.04-1 Right of Way Widths

Roadway Type	RR	UR	RC	UC
ROW Width	60 ft	50 ft	60 ft	60 ft

2. Thoroughfares. In the case that a roadway is shown on the County's Thoroughfare Plan to traverse a proposed subdivision, the right of way for that thoroughfare must be dedicated as part of the subdivision plat. That width of right of way must be in accordance with that found in the most recent update of the Collin County Mobility Plan.

B. Standards for Typical Roadway Types

1. Description of Roadway Types

a. Residential

- i. Rural Residential Roadway - RR - characterized by lower design speeds and minimum pavement widths, anticipating no on-street parking.
- ii. Urban Residential Roadway - UR - development density adjacent to the UR necessitates curbs, enclosed storm sewer systems, and on-street parking.

b. Collector

- i. Rural Collector Roadway - RC - provides for more traffic and higher design speeds than Residential Roadways. No on-street parking.
- ii. Urban Collector Roadway - UC - provides for more traffic and higher design speeds than Residential Roadways. Development density adjacent to the UC necessitates curbs, enclosed storm sewer systems, and on-street parking.

2. Roadway Geometric Design

- a. Figures 1.04-1 through 1.04-4 show the minimum typical sections. Table 1.04-2 summarizes the minimum geometric design criteria.

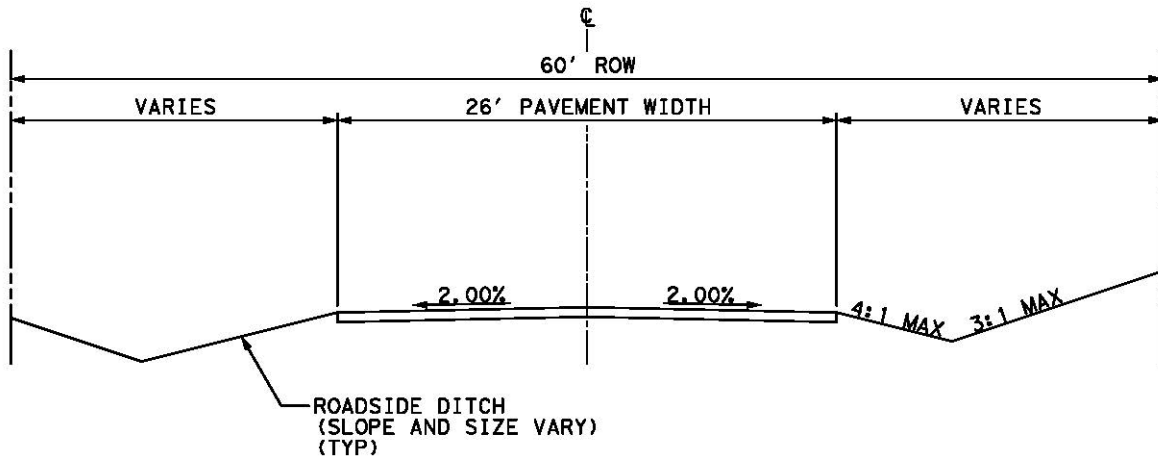

TYPICAL SECTION
 RR - RURAL RESIDENTIAL

Figure 1.04-1 Typical Geometric Section for Rural Residential Roadways - RR

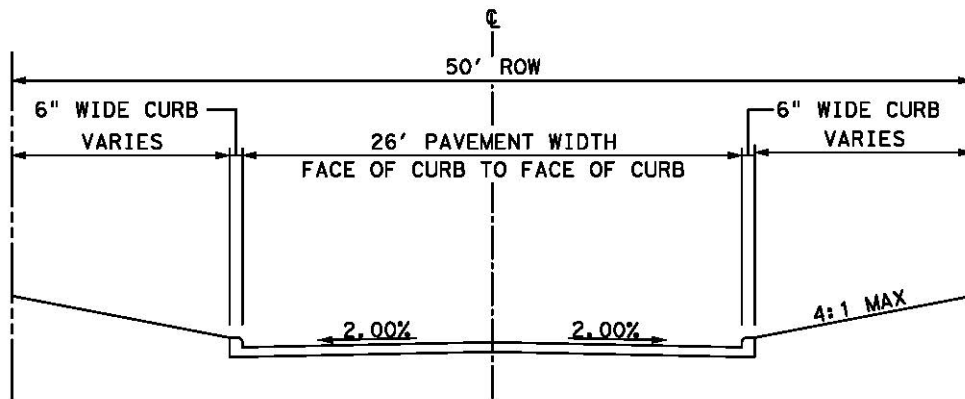

TYPICAL SECTION
 UR - URBAN RESIDENTIAL

Figure 1.04-2 Typical Geometric Section for Urban Residential Roadways - UR

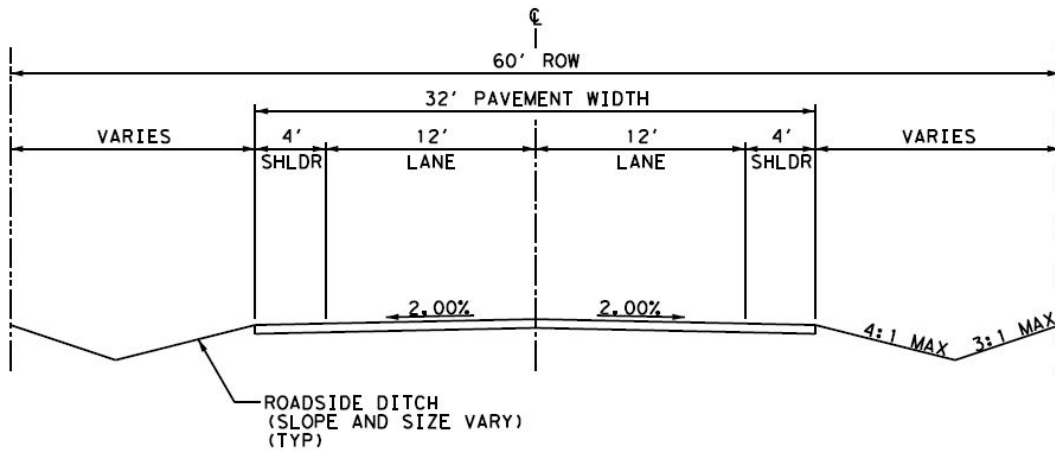

TYPICAL SECTION
RC RURAL COLLECTOR

Figure 1.04-3 Typical Geometric Section for Rural Collector Roadways – RC

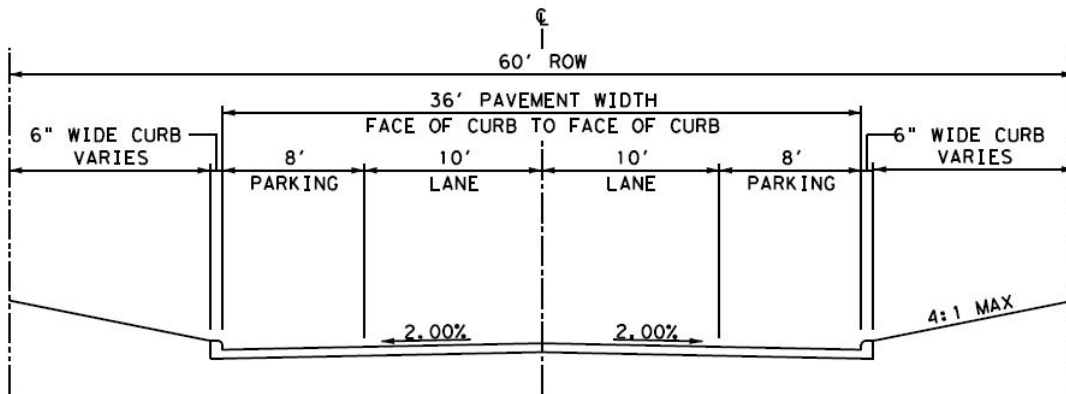

TYPICAL SECTION
UC URBAN COLLECTOR

Figure 1.04-4 Typical Geometric Section for Urban Collector Roadways - UC

Table 1.04-2 Minimum Geometric Design Criteria for Roadways

Criteria	Rural Residential (RR)	Urban Residential (UR)	Rural Collector (RC)	Urban Collector (UC)
Design Speed, V (MPH)	30	30	30	30
Pavement Width (ft)	26	26	32	36
Shoulder Width (ft)	0	0	4	0
Parking Lanes	0	0	0	2
Parking Lane Width (ft)	-	-	-	8
Minimum Grade (%) *	0.0	0.5	0.0	0.5
Maximum Grade (%)	15	15	15	15
Stopping Sight Distance (ft)	200	200	200	200
Min. Horizontal Radii (normal crown) (ft)	335	335	335	335
Min. Vertical Crest Curve (K)	19	19	19	19
Min. Vertical Sag Curve (K)	37	37	37	37

*Provide positive drainage in gutters or ditches

- b. Minimum geometric design criteria is based on Texas Department of Transportation criteria shown in its Roadway Design Manual for Local Roadways. <http://onlinemanuals.txdot.gov/txdotmanuals/rdw/rdw.pdf>
- c. Design Speed – The design speed is a key factor in the horizontal and vertical alignment of roadways. Design features such as pavement width, number of traffic lanes, design speed, minimum and maximum grade, minimum horizontal radii, stopping sight distance, and minimum vertical curve K values for crest and sag curves are listed in Table 1.04-2.
- d. Grades – The maximum allowable grades for Collin County are shown in Table 1.04-2. Proposed roadways should conform to existing topography, where practical, so drainage may be provided. Where feasible, roadways should follow existing topographical valleys or depressions to form a natural collection system for water. Where topographical and/or natural features require grades to exceed the values in Table 1.04-2, approval from the Director of Engineering is required.
- e. Roadway Centerline – The roadway shall be placed in the center of the right of way but may be shifted slightly to avoid trees and other obstacles.
- f. Cross Slope – All roadways shall have a cross-slope of 2%.

- g. Curb and Gutter – All Urban roadway types shall be required to have curb and gutter. Curb shall be six inches (6”) wide. See Figures 1.04-2 and 1.04-4.
- h. Clear Right of Way – The right of way shall be unobstructed and have a maximum slope of 4H:1V adjacent to the outside edge of the traffic lane for the recovery of errant vehicles. Fences, above ground utility appurtenances, trees, shrubs, decorative or monument signs, etc. present a safety hazard and shall not be permitted inside the right of way. The Director of Engineering may consider allowing these items inside the right of way if protected by positive barrier.
- i. Visibility Requirements
 - i. Stopping Sight Distance (SSD) – The available stopping sight distance on a roadway is the distance required by a driver of a vehicle, traveling at a given speed, to bring the vehicle to a stop before reaching a stationary object in its path. SSD includes the distance traveled during driver perception time, reaction time, and the vehicle braking distance. Horizontal/vertical alignment of the roadway and placement of guard fence in curves shall be such that a driver is provided the minimum SSD of the roadway ahead from any point in the center of the travel lane. The minimum SSD can be found in Table 1.04-2.
 - j. Horizontal Alignment - Curvature in the horizontal alignment should be designed for safe operation. Minimum radii of curves, based on design speed and pavement cross-slopes, are shown in Table 1.04-2.
 - k. Vertical Alignment
 - i. Vertical curves are utilized in roadway design to affect gradual change between tangent grades and will result in a design which is safe, comfortable in operation, pleasing in appearance, and adequate for drainage. The required amount of SSD may be found in Table 1.04-2.
 - ii. Table 1.04-2 shows the minimum acceptable K values of Crest and Sag curves. K is the rate of vertical curvature and is equivalent to the horizontal distance in feet required to make a 1% change in grade. When the algebraic difference (A) between two intersecting tangents is greater than 1%, a vertical curve is required. If A is less than 1%, a vertical curve is not required. The value of K is calculated using the following equation:

$$K=L/A$$

where:

K = rate of vertical curvature

L = length of vertical curve (ft)

A = algebraic difference in grades (%)

I. Roadside Safety

- i. Guard Fence – In locations where Clear Right of Way requirements cannot be met, guard fence may be used. For guard fence design requirements, refer to Texas Department of Transportation Roadway Design Manual – Longitudinal Barriers.

C. Intersections

1. In the design of intersections, right angle (90°) crossings are preferred. However, a five-degree (5°) tolerance is allowable.
2. Radii at intersections shall be thirty (30) feet to the edge of pavement or face of curb.
3. A separate grading plan shall be provided for intersections.
4. Intersections shall be spaced no closer than 500 feet unless approved by the Director of Engineering.
5. Intersection Clear Sight Triangle
 - a. Drivers shall have an unobstructed view of roadways they are crossing. A Clear Sight Triangle shall be provided at all intersections. See Figure 1.04-5.
 - i. The MAJOR ROAD is a through road and is not required to stop.
 - ii. The MINOR ROAD may be controlled or uncontrolled.

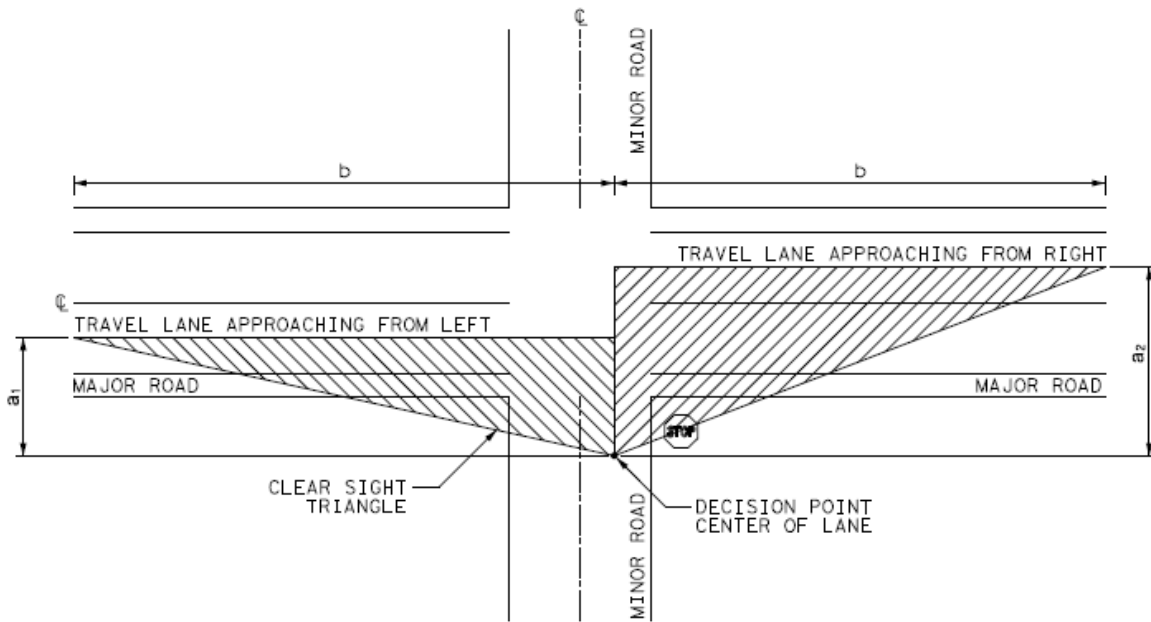

Figure 1.04-5 Intersection Clear Sight Triangle

- b. No vertical objects with a height of more than 2 ft. shall be placed inside the Clear Sight Triangle. This includes fences, trees, shrubs, parked vehicles, mailboxes, above ground utility appurtenances, signs other than those necessary for traffic control and identification of roadway names, etc. Guard fence may be placed inside the Clear Sight Triangle provided the horizontal and vertical alignment of intersecting roadways allows an unobstructed view of oncoming traffic from the minor roadway over the guard fence/railing.
- c. For intersections with County Roadways, the Clear Sight Triangle shall be based on future roadway widths shown on the Collin County Thoroughfare Plan.

Table 1.04-3 Intersection Clear Sight Triangle

Intersecting Roadway Types	Minor Roadway Stop Controlled			Uncontrolled (No Stop Signs)		
	a ₁ (ft)	a ₂ (ft)	b (ft)	a ₁ (ft)	a ₂ (ft)	b (ft)
Residential minor and major	21	33	340	140	140	140
Residential minor, Collector or County Roadway major	21	33	560	N/A	N/A	N/A
Collector minor, Collector or County Roadway major	21	33	560	N/A	N/A	N/A

d. Stop Controlled Intersections

- i. The length of the Clear Sight Triangle along the minor roadway measured from the center of the apparent travel lane approaching from the left should be as shown for “a₁” for Minor Roadway Stop Controlled Intersections in Table 1.04-3. This is depicted as “a₁” in Figure 1.04-5.
- ii. The length of the Clear Sight Triangle along the minor roadway measured from the center of the apparent travel lane approaching from the right should be as shown for “a₂” for Minor Roadway Stop Controlled Intersections in Table 1.04-3. This is depicted as “a₂” in Figure 1.04-5.
- iii. The length of the Clear Sight Triangle along the major (through) roadway from the center of the minor roadway apparent travel lane should be as shown for “b” for Minor Roadway Stop Controlled Intersections in Table 1.04-3. This is depicted as “b” in Figure 1.04-5.

e. Uncontrolled Intersections (No Stop Sign)

- i. The dimensions of the Clear Sight Triangle shall measure as described in Section 1.04.C.6.d for the lengths shown Table 1.04-3 for Uncontrolled Intersections.
- ii. This condition is only applicable to the intersection of two (2) Residential Roadways.

D. Turn Lanes

1. Intersections serving greater than 300 lots will require a traffic impact analysis for turn lane design and traffic signal warrants. The Director of Engineering may waive this requirement on a case-by-case basis.
2. Left and right turn lanes shall be 12 feet wide.
3. The length of turn lanes shall be in accordance with the recommendations in the traffic impact analysis. Left and right turn lanes shall be a minimum of 200 feet (storage length = 100 feet min. and transition length = 100 feet min.) unless

otherwise approved by the Director of Engineering.

E. Driveways

1. Residential – Provides access to a single-family residence, duplex, or multi-family building containing three or fewer dwelling units.
2. Commercial – Provides access to office, retail, institution, or a multi-family building having more than three dwelling units.
3. Design Parameters

Table 1.04-4 Driveway Design Criteria

Criteria	Driveway Type	
	Residential	Commercial
Min. Width (ft)	12	24
Max. Width (ft)	20	40
Radius (ft)	5	30
Throat Depth(ft)	14	28

- a. Width – The width of pavement in the driveway throat. The minimum and maximum widths of driveways are listed in Table 1.04-4.
- b. Radius – The radius shall fall entirely within the subject property. The minimum radius is shown in Table 1.04-4.
- c. Throat Depth – The Depth of the driveway measured from the roadway curb line or edge of pavement to the first on-site location where a driver can make a right turn or a left turn. The full depth of throat shall be an all-weather surface. The minimum throat depth is shown in Table 1.04-4.
- d. Grade – Abrupt grade changes can cause vehicles to move at extremely slow speeds and should be avoided. Grade changes should be limited to 10% for residential driveways and 8% for commercial driveways.
- e. Spacing – Driveways shall be spaced so conflicting movements do not overlap at adjacent driveways or at driveways on opposite sides of the roadway. The minimum spacing between driveways shall be 40 feet from edge to edge.
- f. Driveway culverts shall conform to the Collin County Drainage Design

Standards and the Collin County Public Works Culvert /Driveway Permit.

- g. Culvert/Driveway Permits – A permit is required for all residential and commercial driveways with connections to County Roadways.

F. Sidewalks

1. Where sidewalks are proposed, they must meet the following:
 - a. Collin County considers a sidewalk to be an “accessible route” as specified in Section 4.3 of the Texas Accessibility Standards (TAS) and considers a public sidewalk a “facility” under the TAS and the U.S. Department of Justice Americans with Disabilities Act (ADA) regulations at 28 CFR. Part 35. Sidewalks are subject to the requirements of Chapter 469 of the Texas Government Code for Texas Department of Licensing and Registration (TDLR) inspection purposes (per 16 Texas Administrative Code, Chapter 68).
 - b. Sidewalks shall be wholly contained within dedicated right of way or pedestrian easements. County maintenance of sidewalks will not be provided unless sidewalk is contained within dedicated right of way.
 - c. Sidewalks adjacent to the back of curb shall have a minimum width of six (6) feet.
 - d. Sidewalks not adjacent to the back of curb shall have a minimum separation from the back of curb of three (3) feet and a minimum width of five (5) feet.

G. Roadway Layout

1. Proposed roadways shall satisfy the requirements of these Standards relating to the design of roadways and shall contain a written certification from an Engineer or Surveyor that the locations and dimensions of roadways as set forth and laid out on the plat are in accordance with these Regulations.
2. Residential Roadways shall be so laid out that their use by through traffic will be discouraged. Collector Roadways shall be used to provide access to adjacent subdivisions.
3. All residential subdivisions shall provide a minimum of two (2) points of access for subdivisions having thirty (30) or more lots, plus one (1) point of access for each seventy-five (75) lots thereafter, including roadway stubs for future connections or extensions into a future development or phase and/or connection to an existing major collector or thoroughfare or as required by the Director of Engineering.
4. Points of access shall be placed so that the distance between points of access, measured in a straight line between accesses, is no less than one-half the maximum overall diagonal dimension of the subdivision.
5. Proposed roadways should conform to existing topography, to the extent possible, in order to eliminate or reduce potential drainage problems and to form a drainage collection system for surface water runoff.

H. Cul-de-sacs

1. Cul-de-sacs may be permitted where the form or contour of the land makes it difficult to plat with connecting roadways.
2. Cul-de-sacs shall serve less than thirty (30) lots.
3. Cul-de-sacs shall provide proper access to all lots.
4. Cul-de-sacs shall provide a turn-around with an outside pavement radius of at least fifty (50) feet. The right of way radius shall be at least sixty (60) feet.

1.05 PAVEMENT - GENERAL

A. General

1. The County requires the following minimum standards for pavement design, materials, construction, and maintenance for all roadways. These minimum standards are not intended to replace the professional judgement of the Geotechnical Engineer. Modification of the standards may be approved by the Director of Engineering on a case by case basis submitted in writing.
2. Unless otherwise noted, materials and construction practices for all new or rehabilitated roadway pavements shall be in accordance with the North Central Texas Council of Governments (NCTCOG) Public Works Construction Standards, most recently adopted version, with modifications specified in these Standards. Requests for deviations from these requirements shall be submitted, in writing, to the Director of Engineering for approval.

1.06 PAVEMENT - DESIGN

A. Pavements for New Residential Roadways

1. Refer to Figure 1.06-1 for minimum Asphalt Residential, AR, pavement section.
2. Refer to Figure 1.06-2 for minimum Concrete Residential, CR, pavement section.
3. AR and CR pavement types are acceptable for use in construction of Rural Residential Roadways, RR.
4. CR pavement type is acceptable for use in construction of Urban Residential Roadways, UR.
5. An alley intended to become public right of way maintained by Collin County shall meet the pavement design requirements for Residential Roadways.
6. Lime Stabilized Subgrade
 - a. Lime stabilization series is required for each soil type expected to be encountered across the site in the portion of the subgrade to be stabilized for all roadways.
 - b. Optimum lime addition percentage shall be determined by Tex-112-E Admixing Lime to Reduce Plasticity Index of Soils (Atterberg Limits Soil-Lime Series).

- c. Minimum design criteria are:
 - i. Plasticity Index < 15 after mellowing
 - ii. Swell potential < 1.0 percent under 200 pounds per square feet during stress test (ASTM D 4546)
- d. The minimum lime content specified shall be the percentage, by weight, of hydrated lime as determined by lime stabilization series plus 1.0%, and in no case be less than the County's minimum requirements as described above.
- e. The Director of Engineering may consider other types of and percentages of lime based on geotechnical laboratory's tests, evaluations and recommendations described in engineering reports provided and paid for by the Developer.
- f. The laboratory testing and must address the presence of sulfates in subgrade soils, as applicable.

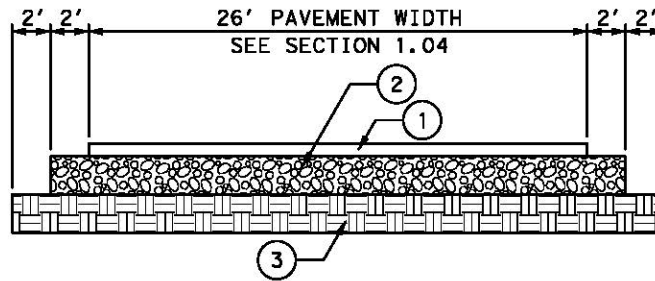

- ① 2-COURSE SURFACE TREATMENT, OR
2" HOT MIX ASPHALT CONCRETE
IN ACCORDANCE WITH SECTION 1.07.C
OR 1.07.D.
- ② 8" FLEXIBLE BASE
IN ACCORDANCE WITH SECTION 1.07.B
- ③ MIN. 7% LIME STABILIZED SUBGRADE, 6" THICKNESS
IN ACCORDANCE WITH SECTION 1.06.A.6.

AR
ASPHALT PAVEMENT
RESIDENTIAL ROADWAY

Figure 1.06-1 Minimum Asphalt Residential Pavement Section

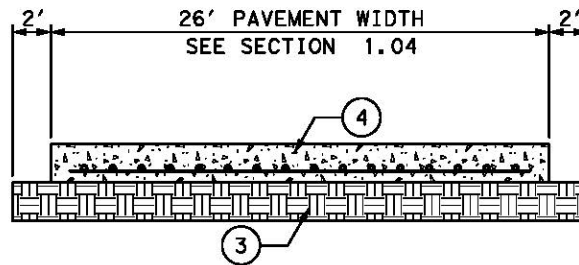

- ④ 6" PORTLAND CEMENT CONCRETE PAVEMENT
#3 BARS @ 18" O.C. BOTH WAYS
IN ACCORDANCE WITH SECTION 1.07.E.
- ③ MIN. 7% LIME STABILIZED SUBGRADE, 6" THICKNESS
IN ACCORDANCE WITH SECTION 1.06.A.6.

CR
CONCRETE PAVEMENT
RESIDENTIAL ROADWAY

Figure 1.06-2 Minimum Concrete Residential Pavement Section

B. Pavements for New Collector Roadways

1. A Report of Geotechnical Investigation and Pavement Design identifying the appropriate pavement design for the traffic resulting from the development is required for Collector Roadways, RC & UC, serving more than 150 total lots, including those outside the Subdivision (ie. future phases or connected subdivisions). This report shall be signed and sealed by an Engineer. This requirement may be modified on a case by case basis as approved by the Director of Engineering in writing.
2. Pavements for turn lanes, where required, shall be designed by an Engineer and shall be included in the Report of Geotechnical Investigation and Pavement Design. Turn lane pavements shall be of similar type as adjacent roadway pavement.
3. Geotechnical Investigation Requirements
 - a. Field Sampling Protocol
 - i. Borings shall be drilled on center of proposed travel lanes at 500-foot spacing (or less), alternating between each roadway direction to a depth of at least 15 feet below finished subgrade or until competent rock is encountered, whichever is shallower. On existing roadways, borings shall be taken just outside the limits of the existing roadway.
 - ii. Borings shall be sampled at 3-foot intervals or less to a depth of 10 feet below finished subgrade, and at 5-foot intervals or less thereafter.
 - iii. Bulk samples of each soil type encountered in the upper 5 feet shall be taken for Laboratory Investigation.

- iv. Report must address heavily treed areas, where such trees are to be removed. Additional borings may be required in these areas.
- b. All pavement shall have a 30-yr design life.
- c. Pavement design shall be based on American Association of State Highway and Transportation Officials (AASHTO) current edition of Guide for Design of Pavement Structures.
- d. Lime Stabilized Subgrade
 - i. Lime stabilization series is required for each soil type expected to be in the portion of the subgrade to be stabilized.
 - ii. Optimum lime addition percentage shall be determined by Tex-112-E Admixing Lime to Reduce Plasticity Index of Soils (Atterberg Limits Soil-Lime Series).
 - iii. Minimum design criteria are:
 - (1) Plasticity Index < 15 after mellowing
 - (2) Swell potential < 1.0 percent under 200 pounds per square feet during stress test (ASTM D 4546)
 - iv. The minimum lime content specified shall be the percentage, by weight, of hydrated lime as determined by lime stabilization series plus 1.0%, and in no case be less than the County's minimum requirements as described above.
- e. The laboratory testing and geotechnical recommendations must address the presence of sulfates in subgrade soils, as applicable.
- f. Alternative subgrade options may be proposed by the Geotechnical Engineer and may be approved by the Director of Engineering.
- g. Report of Geotechnical Investigation and Pavement Design
 - i. County review of the Report of Geotechnical Investigation and Pavement Design will be conducted to verify if the pavement and subgrade design has been performed in general conformance to the County's requirements and shall not be considered a detailed technical review of the pavement and subgrade design for adequacy, accuracy, or completeness. The Geotechnical Engineer performing the pavement and subgrade design shall remain responsible for the technical accuracy, adequacy, and completeness of the pavement and subgrade design and shall not be relieved of any responsibility for such as a result of the County's review.
 - ii. The information and recommendations contained in the Report of Geotechnical Investigation and Pavement Design and any subsequent re-evaluation and/or supplemental reports shall be approved in writing by the Director of Engineering.

1.07 PAVEMENT - MATERIALS

A. Subgrade

1. Embankment (Fill)

- a. Material used for embankment may be generated on-site or off-site. All embankment material must meet the requirements of these Standards.

B. Flexible Base

1. Flexible Base shall meet the requirements of NCTCOG Item 301.5 - Flexible Subbase or Base (Crushed Stone), Grade 1. Crushed stone shall be produced and graded from oversized quarried aggregate that originates from a single, naturally occurring source. Do not use gravel or multiple sources.
2. Crushed concrete shall not be allowed for use in Flexible Base for two-course surface treatment roadways.
3. Base material supplier shall be approved by the Director of Engineering.

C. Surface Treatments

1. Minimum surface treatments for roadways must be a prime coat applied to flexible base, two-course surface treatment application, and, when precoated aggregate is not used, a fog seal meeting the material and application rate requirements of this section.
2. The Developer's Engineer shall specify materials and application rates, meeting the requirements listed herein, on the civil construction plans, or may submit alternative materials and rates for consideration to the Director of Engineering.
3. Bituminous materials shall be as defined in the TxDOT Standard Specifications for Construction and Maintenance of Highways, Streets, and Bridges, current edition, Item 300 - Asphalts, Oils, and Emulsions.
4. Aggregate type and size shall be as defined in the TxDOT Standard Specifications for Construction and Maintenance of Highways, Streets, and Bridges, current edition, Item 302 - Aggregates for Surface Treatments.
 - a. Aggregate may be precoated. Fog seal is not required if precoated aggregate is used.
 - b. Lightweight aggregates shall not be allowed.

5. Prime Coat
 - a. Prime coat shall be MC-30 applied at an actual rate between 0.20 and 0.40 gallons per square yard. Minimum cure time prior to 1st course application is 24 Hours.
6. First Course Surface Treatment
 - a. Approved first course material shall be CRS-2, CRS-2H, CRS-2P or other material approved by the Director of Engineering, applied at an actual rate between 0.40 and 0.50 gallons per square yard with Grade 3 aggregate applied at a rate of 1 cubic yard of aggregate per 85 to 95 square yards of surface treatment (1cy/85sy to 1cy/95sy). Minimum cure time prior to 2 course application is 24 hours.
7. Second Course Surface Treatment

Approved second course material shall be CRS-2, CRS-2H, CRS-2P or other material approved by the Director of Engineering, applied at an actual rate between 0.40 and 0.50 gallons per square yard with Grade 4 aggregate applied at a rate of 1 cubic yard of aggregate per 100 to 110 square yards of surface treatment (1cy/100sy to 1cy/110sy).
8. Fog Seal
 - a. Fog seals shall be required when aggregates used in surface treatments are not pre-coated.
 - b. Fog seal material shall be CSS-1 or SS-1 applied at an actual rate between 0.15 and 0.25 gallons per square yard. Other materials may be submitted for approval to the Director of Engineering.
- D. Hot-Mix Asphalt Concrete (HMAC)
 1. The mix design for HMAC shall be reviewed and approved by the Developer's Engineer and submitted to the Director of Engineering for approval.
 2. Asphalt Binders for Hot-Mix Asphalt Concrete shall meet the requirements of NCTCOG Item 302.3.2 - Performance Graded (PG) Asphalt Binders. PG Binders for surface pavements shall be PG 70-22.
 3. All paving mixtures shall meet the requirements of NCTCOG Item 302.9 - Hot-Mix Asphalt Pavement.
 - a. For Dense-Graded mixtures, use Type D - Fine Surface requirements.
 - b. For Superpave mixtures, use ½" Fine Surface requirements.
- E. Portland Cement Concrete
 1. The mix design for Portland Cement Concrete shall be reviewed and approved by the Developer's Engineer and submitted to the Director of Engineering for approval.
 2. Concrete for pavement shall meet the requirements of NCTCOG Item 303 - Portland Cement Concrete Pavement, Standard Class P1 (4,000 psi).

1.08 PAVEMENT - CONSTRUCTION

A. Subgrade

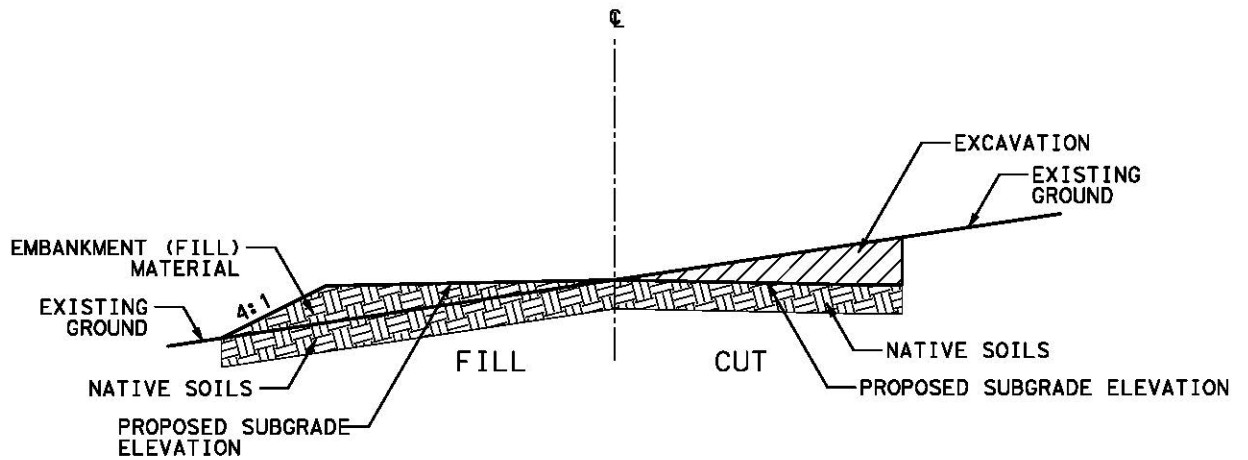

NOTE:

1. NATIVE SOILS: ROLLER COMPACT AND PERFORM DENSITY TESTING BY PROOFROLLING.
2. EMBANKMENT (FILL) MATERIAL: PLACE IN LOOSE LIFTS LESS THAN 8" THICK. COMPACT TO 95% STANDARD PROCTOR DENSITY, MINUS 2 TO PLUS 4 PERCENT OF OPTIMUM MOISTURE. PERFORM DENSITY TESTING IN ACCORDANCE WITH SECTION 1.09.D.3
3. SUBGRADE PREPARATION SHALL EXTEND A MINIMUM 2' BEYOND OUTER EDGES OF AGGREGATE BASE COURSE, CONCRETE PAVEMENT, OR BACK OF CURB.

SUBGRADE PREPARATION

Figure 1.08-1 Subgrade Preparation Requirements

1. Subgrade preparation shall be in accordance with NCTCOG Item 203 - Site Preparation and NCTCOG Item 301.1.1 - Subgrade Preparation, with modifications herein.
2. Subgrade preparation shall extend a minimum of 2 feet beyond the proposed edge of flexible base, edge of concrete pavement, or back of curb for all roadways.
3. Excavation (Cut):
 - a. Remove existing soils to proposed subgrade elevation.
 - b. Perform additional excavation necessary for complete removal of vegetation. Backfill stump holes and depressions with approved embankment material.
 - c. Compact existing soils to 95% Standard Proctor Density as determined by ASTM D-698, at moisture contents of minus 2 to plus 4 percent of optimum moisture. Soft and yielding spots shall be corrected through additional compaction, or by removal of the existing material and placement of approved embankment material in compacted lifts.
4. Embankment (Fill):
 - a. Prior to placement of any embankment, all clearing and grubbing shall be completed. Backfill stump holes and depressions with approved embankment material.
 - b. Existing soils shall be roller compacted, after clearing and grubbing and prior to placement of embankment material, as described in Section 1.08.A.3. Soft and yielding spots shall be corrected through additional compaction, or by removal of the existing material and placement of approved embankment material in compacted lifts.
 - c. Scarify the existing soils a minimum of 8 inches before placement of the first lift of embankment material to provide a bond between existing and new material.
 - d. Place embankment material in loose lifts not to exceed 8 inches and of sufficient width.
 - e. Compact embankment to 95% Standard Proctor Density as determined by ASTM D-698, at moisture contents of minus 2 to plus 4 percent of optimum moisture.

5. Lime Stabilized Subgrade
 - a. All subgrade soils shall be treated with the quantity of lime determined as described in 1.06, to the depths indicated in Figures 1.06-1 and 1.06-2 or in the Report of Geotechnical Investigation and Pavement Design, and in accordance with NCTCOG Item 301.2 - Lime Treatment.
 - b. Compact lime stabilized subgrade to 95% Standard Proctor Density as determined by ASTM D-698, at moisture contents of minus 2 to plus 4 percent of optimum moisture.
- B. Flexible Base
 1. Flexible Base shall be placed to the final, compacted depth indicated in Figure 1.06-1 or in the Report of Geotechnical Investigation and Pavement Design, in accordance with NCTCOG Item 301.5 - Flexible Base.
 2. All Flexible Base shall be density controlled. Compact flexible base to 95% Modified Proctor Density as determined by ASTM D-1557, at moisture contents of minus 2 to plus 4 percent of optimum moisture.
 3. Prime Coat shall be placed within 72 hours of successful density testing. Prime Coat shall only be applied if moisture content is maintained. Prime Coat shall meet the requirements of Section 1.07.C.5.
- C. Surface Treatments
 1. Surface Treatments shall be placed in accordance with TxDOT Standard Specifications for Construction and Maintenance of Highways, Streets, and Bridges, current edition, Item 316 - Seal Coat.
 2. Paving season for Emulsions is March 1 to October 31 pending acceptable weather.
 3. AC products may only be used with approval from the Director of Engineering. Paving season for AC products is May 15 to August 31 pending acceptable weather.
 4. Unless otherwise approved, do not start paving operations unless complete roadway construction can be completed by October 31.
 5. Field conditions and traffic may require the application of an additional (intermediate) surface treatment layer meeting the requirements of Second Course Surface Treatment to preserve the integrity of layers below. Typically, this occurs when final AC asphalt surface treatment cannot be placed before October 31.

D. Hot-Mix Asphalt Concrete (HMAC)

1. Hot-Mix Asphalt Concrete shall be placed to the depth indicated in Figure 1.06-1 or in the Report of Geotechnical Investigation and Pavement Design, in accordance with NCTCOG Item 302.9 - Hot-Mix Asphalt Pavement.

E. Portland Cement Concrete

1. Portland Cement Concrete Pavement shall be placed to the depth indicated in Figure 1.06-2 or in the Report of Geotechnical Investigation and Pavement Design, in accordance with NCTCOG Item 303 - Portland Cement Concrete Pavement.
2. Reinforcing steel shall be placed as indicated in Figure 1.06-2.
3. All joints shall be sealed in accordance with NCTCOG Item 303.3.4 – Joints.

1.09 PAVEMENT - TESTING, INSPECTION & ACCEPTANCE

A. General

1. Testing and inspections required by the Director of Engineering, to determine conformance to specifications, shall be performed by a testing laboratory contracted by Collin County.
2. The County shall perform verification testing on compacted subgrade, lime stabilized subgrade, flexible base, surface treatments, Hot-Mix Asphalt Concrete, and Portland Cement Concrete at a laboratory of their choosing.
3. The County must be notified at least 48 hours in advance of any testing performed. The County will determine if it must be present for sampling and testing.
4. The Developer shall bear all costs for testing and inspection including all verification testing performed by the County.
5. Sampling Procedures
 - a. The County shall determine locations for testing or sampling materials for acceptance.

B. Pre-Construction Submittals Required

1. The items in this section shall be submitted to the Director of Engineering prior to commencement of construction.
2. Embankment (Fill)
 - a. Gradation, Atterberg Limits, and Standard Proctor curves as determined by ASTM D-698 performed on bulk samples of all embankment materials to be used.
 - b. Embankment material must be tested and these test results must be submitted to the Director of Engineering before they are allowed.
3. Lime Stabilization

- a. Results of lime series, sulfates testing, and Standard Proctor curves as determined by ASTM D-698 for all subgrade soils to be stabilized.
- 4. Flexible Base
 - a. Gradation, Atterberg Limits, and Modified Proctor curves as determined by ASTM D-1557 performed on bulk samples.
 - b. Certification that the flexible base is crushed stone.
- 5. Surface Treatments
 - a. Certifications and application rates for asphalt binders and aggregates to be used.
- 6. Hot-Mix Asphalt Concrete (HMAC)
 - a. Mixture design from the HMAC Supplier, certified by the Developer's Engineer.
- 7. Portland Cement Concrete
 - a. Mixture design from the Portland Cement Concrete Supplier. The Developer's Engineer shall certify that the mixture design is in accordance with the requirements of the Civil Construction Plans and Specifications.
 - b. Supplier mixture design verification shall have been performed within the prior 6 months of the submittal date of the mixture design.
 - c. Shop drawings of rebar layouts and material certifications.
- C. Certified Elevations
 - 1. Certified elevations (spot elevations) shall be provided to verify pavement sections, roadway grades, and drainageways are constructed in conformance with the Civil Construction Plans. A tabulation of certified elevations is acceptable.
 - 2. Certified elevations, by a Surveyor, shall be taken as follows:
 - a. Asphalt pavements: sub-grades and base for all asphalt pavements. Also surface for HMAC pavement. Elevations shall be recorded 6-inches from both edges of pavement and at roadway centerline, measured along the centerline and selected at random, not to exceed 100-ft.
 - b. Concrete pavements: sub-grades and concrete surface. Elevations shall be recorded 6-inches from both edges of pavement or face of curb and roadway centerline, measured along the centerline and selected at random, not to exceed 100-ft.
 - c. Ditch/culvert flowlines: Elevations shall be recorded at 100-foot station intervals along ditch flowlines and at the upstream and downstream invert of all culverts.
 - d. Detention ponds: Elevations shall be recorded along the embankment at 250-foot intervals. Elevations shall be recorded at the embankment and pilot channel, at the most upstream and downstream ends of the pond. Elevations

shall be recorded for all openings in the outfall structure.

3. Certified elevations shall be submitted to the Director of Engineering for verification prior to beginning construction of the next roadway item. The survey data shall be in tabular form listing roadway station, proposed elevation, measured elevation and elevation difference. The Developer's Engineer must sign off that the grade verification meets acceptable tolerances for design.

D. Subgrade

1. A subgrade compaction report must be presented to the County and Director of Engineering prior to paving. Reports are only valid for 72 hours. Reports received on a Friday are valid until noon on the following Monday. Testing performed before inclement weather may be required to be repeated at the County's discretion.
2. Excavation
 - a. Density shall be tested by proof rolling in accordance with NCTCOG Item 203 - Site Preparation and NCTCOG Item 301.1.1 - Subgrade Preparation.
 - b. The County must be present during proof rolling.
 - c. Completely filled water trucks are acceptable for use as proof rolling equipment.
3. Embankment (Fill)
 - a. Tests for compacted embankment density and moisture content shall be taken in accordance with Tex-115-E. Tests shall be performed at a frequency determined by the County on a case by case basis. Generally, density tests will be taken in a series of three, one at each edge of roadway and one closer to the centerline, every three hundred longitudinal feet, with a minimum of one test per lift. A minimum of three (3) test series shall be performed for each roadway.
4. Lime
 - a. Native soils shall be tested by proof rolling prior to lime stabilization.
 - b. Lime stabilized subgrade shall be proof rolled prior to density testing and placement of base.
 - c. The County must be present during proof rolling.
 - d. Completely filled water trucks are acceptable for use as proof rolling equipment.
 - e. Tests for Plasticity Index of treated soils shall be done for every 2,500 CY of treated subgrade. A minimum of three (3) tests shall be performed for each roadway.
 - f. Tests for compacted lime stabilized subgrade density and moisture content shall be taken in accordance with Tex-115-E. Tests shall be performed at a frequency determined by the County on a case by case basis. Generally, density tests will be taken in a series of three, one at each edge of roadway

and one closer to the centerline, every three hundred longitudinal feet, with a minimum of one test per lift. A minimum of three (3) test series shall be performed for each roadway.

E. Flexible Base

1. Compacted base shall be proof rolled prior to density testing and placement of surface treatment. The County must be present during proof rolling.
2. Verification of flexible base depth shall be by certified survey only. Coring, probing, or other destructive test methods are prohibited.
3. Sampling and testing for gradation should be done for every 5,000 CY of flexible base.
4. Tests for compacted flexible base density and moisture content shall be taken in accordance with Tex-115-E. Tests shall be performed at a frequency determined by the County on a case by case basis. Generally, density tests will be taken in a series of three, one at each edge of roadway and one closer to the centerline, every three hundred longitudinal feet, with a minimum of one test per lift. A minimum of three (3) test series shall be performed for each roadway.

F. Surface Treatments

1. Contractor shall provide asphalt quantities, measured in gallons, and aggregate quantities, measured in cubic yards, for all surface treatments placed, to the Director of Engineering. This information shall be provided for each course, for each roadway.

G. Hot-Mix Asphalt Concrete (HMAC)

1. Testing for in-place air voids shall be conducted by taking two (2) cores per 500 tons of asphalt placed, at least once per day of placement. A minimum of 25% of cores taken per day must be taken within 1-ft of the edge of compacted asphalt.
2. Companion loose samples for determination of in-place air voids shall be taken per 2,000 tons of asphalt placed, at least once per day of production.
3. Core samples taken for in-place air voids may be used to confirm placed pavement depth but may not be used to substitute certified elevations by a Surveyor.

H. Portland Cement Concrete

1. At the point of concrete placement, four cylinders (2 at 7 days, 2 at 28 days) for each 50 CY per class, per day, for hand poured and 150 CY per class, per day for machine poured, shall be tested for compressive strength.
2. For slump, entrained air and temperature of concrete, one test for each 50 CY per class, per day, for hand poured and 150 CY per class, per day for machine poured.
3. Slump, entrained air, and temperature tests should be performed on the same load from which strength test specimens are made. Entrained air tests should only be performed when entrained air concrete is specified in civil plans.

4. Results of these tests shall meet the requirements of NCTCOG Item 303 – Portland Cement Concrete Pavement.

1.10 MAINTENANCE

A. Maintenance

1. The Developer shall maintain all pavements within the subdivision until the release of the Maintenance Bond by the Director of Engineering and adoption of maintenance responsibility by the County. Refer to the Collin County Subdivision Regulations for additional information.
2. Asphalt pavements experiencing minor oxidation and cracking may be maintained with periodic placement of one-course surface treatment.
3. A one-course surface treatment may be required prior to final acceptance of the roadway if excessive wear or repairs are present. The one-course surface treatment shall meet the requirements of the second course surface treatment in Section 1.07.C.

B. Patching

1. Patching of roadways is required to repair rutting of asphalt pavements and differential settlement in concrete pavements. Patching shall be in accordance with the details, materials, and specifications in Appendix A.

C. Joint Repair

1. Repair of joints in concrete pavements shall be in accordance with the details, materials, and specifications in Appendix A.

1.11 APPROVAL FOR COUNTY MAINTENANCE

A. Acceptance of Roadways for County Maintenance

1. Refer to the Collin County Subdivision Regulations for procedures and requirements for County acceptance of roadways for County maintenance.

DRAFT

CONCRETE EXPANSION JOINT REPAIR

A. Scope

The work shall consist of repairing existing expansion joints including saw cutting, removal, joint preparation, and placement of backer rod and joint sealant.

B. Materials

1. Joint sealing compound shall consist of hot poured polymer or ready-mixed cold-applied sealant, or other material approved by the Owner. It shall not crack or break when exposed to low temperatures. The cured sealant must not pick up or “track” at elevated road temperature.

- a. Hot Poured Polymer

The sealing compound shall meet the requirements of NCTCOG Public Works Construction Standards Item 303.2.14.1.1.

- b. Ready-Mixed Cold-Applied

The sealant shall meet the requirements of NCTCOG Public Works Construction Standards Item 303.2.14.1.2.

- c. Thermoplastic Cold-Applied

If approved by the Owner, thermoplastic cold-applied jointing material may be used according to manufacturer’s recommendations.

2. Backer rod shall be round, closed cell, non-gassing, expanded polyethylene, polyurethane or polyvinyl chloride polypropylene flexible foam compatible with the sealant. The diameter of the backer rod shall be 25% larger than the joint opening and such that a tight fit results, and the backer rod will not be displaced during sealant application or sealant curing, in accordance with the manufacturer’s recommendations and as shown on the drawings.

3. Preformed bituminous fiber material boards shall consist of a bituminous impregnated felt or two layers of glass-fiber felt. The mastic shall comprise mineral fillers and reinforcing fibers and many contain thin strips of reinforcing sheet material.

C. Surface Preparation and Application

Cutting or routing expansion joints will involve saw cutting or routing as required to attain a minimum 1-1/2” width for the full slab depth. Concrete cutting equipment shall be equipped with carbide or diamond blades. All dried laitance and contaminants shall be removed.

Cleaning: Each joint face shall be wiped or sandblasted. The sandblasting nozzle must be held at an angle or fitted with deflectors to direct the sand against the joints face within one or two inches of the concrete. A minimum of one pass shall be made for each joint face.

After wiping or sandblasting, the joint cavity shall be cleaned, removing all sand or other debris that would interfere with joint closure. Just prior to placing backer rod and sealant, the joints shall be air-blasted to remove sand and dust. Air compressors used for sandblasting and air blasting shall be equipped with traps to remove moisture and oil from the air. Air blasting shall be done in one direction only.

The joint shall be considered clean when no residue is evident after rubbing a finger or dark lint free cloth along the cleaned dry joint face. The joint shall be completely clean and air-dried, as determined by the Engineer, for a minimum of 24 hours under natural drying conditions before proceeding with the application of sealant.

Alternate cleaning proposals may be submitted in writing to the Director of Engineering for consideration.

Sealant Installation: Install preformed bituminous fiber material board. Backer rod shall be placed such that the distance between the top of the installed backer rod and top of slab is 1".

Joints must be clean and dry when the sealant is installed. Drying of the joint surfaces may only occur from natural weather conditions.

During the sealant placement the nozzle of the sealant applicator shall be moved steadily along the joint, pushing the sealant ahead to form the required cross section. The minimum and maximum temperature of sealant at the time of installation shall be in accordance with the manufacturer's recommendation.

Immediately after placement and before a skin forms, the sealant shall be tooled, forcing it onto the backer rod surface and against the joint faces. The finished tooled surface shall be recessed below the concrete surface by 1/4". Excess sealant on the concrete surface shall be removed.

D. Delivery and Storage

The sealant material shall be delivered in original, tightly sealed containers, clearly labeled with the manufacturer's name, product identification and lot numbers where applicable.

The unopened sealant material shall be stored out of the weather, in original, tightly sealed containers, as recommended by the manufacturer. Storage temperature shall not exceed 90 degrees Fahrenheit.

E. Measurement and Payment

For items of work for which specific unit prices are established in the contract, the quantity of repaired joints will be determined to the nearest lineal foot by measurement of acceptably installed joint repair along each joint. Payment for joint repair will be made at the contract unit price for the joint specified. Such payment will constitute full compensation for furnishing, transporting, placement and application of all materials;

and saw cutting and preparing the concrete joints including labor, tools, equipment, and all other items necessary and incidental to the completion of the work.

Compensation for any item of work described in the contract but not listed in the bid schedule will be included in the payment for the item of work to which it is made subsidiary.

DRAFT

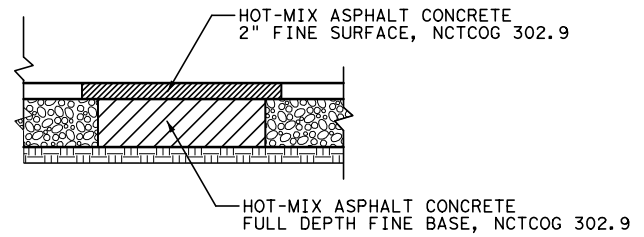
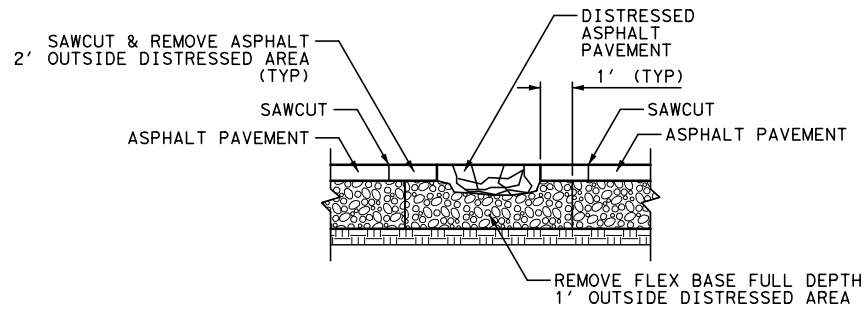

ASPHALT PATCHING

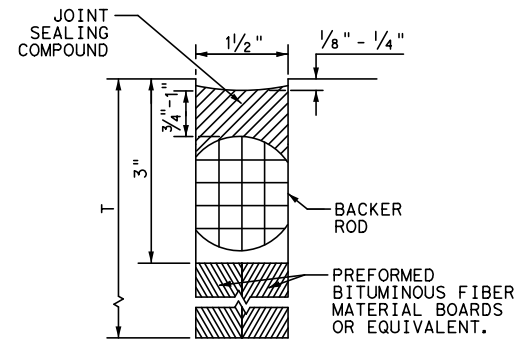

EXPANSION JOINT REPAIR

**DETAILS
ASPHALT PATCHING REPAIR
EXPANSION JOINT REPAIR**

TABLE NO. 1 STEEL BAR SIZE AND SPACING					
SLAB THICKNESS AND BAR SIZE		LONGITUDINAL*		TRANSVERSE*	
		REGULAR BARS	TIEBARS	BAR	TIEBARS
T (IN.)	BAR SIZE	SPACING (IN.)	SPACING (IN.)	SPACING (IN.)	SPACING (IN.)
6.0	#5	7.5	7.5	24	24
6.5		7.0	7.0		
7.0		6.5	6.5		
7.5		6.0	6.0		
8.0	#6	9.0	9.0	24	24
8.5		8.5	8.5		
9.0		8.0	8.0		
9.5		7.5	7.5		
10.0		7.0	7.0		
10.5		6.75	6.75		
11.0		6.5	6.5		
11.5		6.25	6.25		
≥12.0		6.0	6.0		

* USE 12" SPACING AS FIRST AND LAST SPACING AT END OR SIDE FOR ALL BARS.

GENERAL NOTES

- MULTIPLE PIECE TIEBARS SHALL BE USED WHEN THE REPAIR AREA MUST BE PLACED IN TWO STAGES DUE TO SEQUENCE OF CONSTRUCTION.
- FULL DEPTH SAW CUTS SHALL BE MADE AROUND THE PERIMETER OF THE AREA TO BE REPAIRED. THE CUT SHALL BE MADE AT A RIGHT ANGLE TO THE PAVEMENT EDGE AND TO THE CENTER LINE OF THE PAVEMENT.
- AT LEAST ONE LONGITUDINAL FULL DEPTH SAW CUT SHALL BE AT AN EXISTING LONGITUDINAL JOINT.
- ADDITIONAL SAW CUTS MAY BE REQUIRED WITHIN THE AREA OF THE REPAIR TO FACILITATE REMOVAL OF THE CONCRETE OR TO ALLEVIATE BINDING OF THE FULL DEPTH SAW CUT AT THE REPAIR EDGE.
- THE SAW CUTS WHICH EXTEND OUTSIDE THE AREA OF THE REPAIR WILL BE CLEANED AND FILLED WITH A CEMENTITIOUS GROUT APPROVED BY THE OWNER.
- EXISTING LONGITUDINAL AND TRANSVERSE JOINTS REMOVED DUE TO REPAIR OPERATION SHOULD BE RESTORED IN ACCORDANCE WITH NCTCOG ITEM 303.

GENERAL NOTES

- THE SAW CUTS WHICH EXTEND OUTSIDE THE AREA OF THE REPAIR WILL BE CLEANED AND FILLED WITH A CEMENTITIOUS GROUT APPROVED BY THE ENGINEER.
- EXISTING LONGITUDINAL AND TRANSVERSE JOINTS REMOVED DUE TO REPAIR OPERATION SHOULD BE RESTORED IN ACCORDANCE WITH NCTCOG ITEM 303.

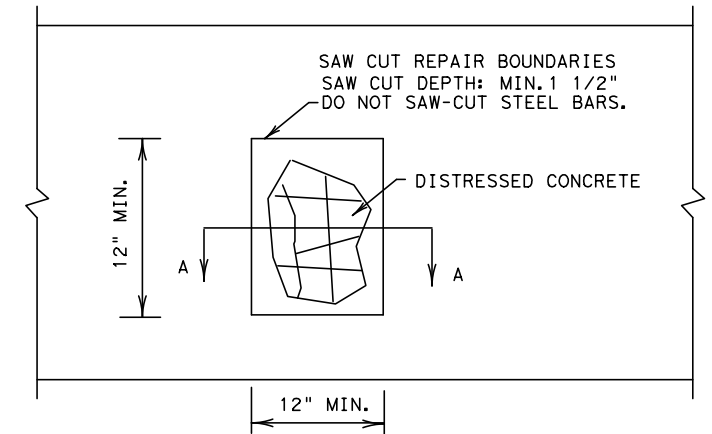

PLAN VIEW

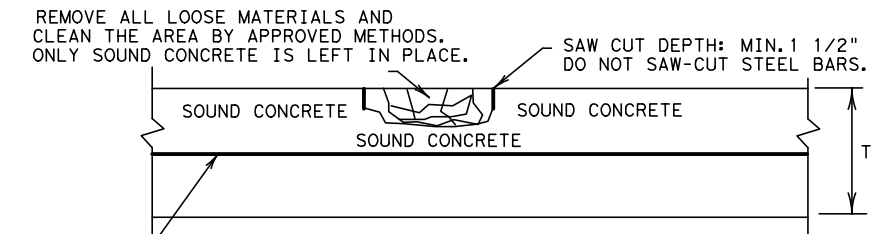

REMOVE ALL LOOSE MATERIALS AND CLEAN THE AREA BY APPROVED METHODS. ONLY SOUND CONCRETE IS LEFT IN PLACE.

LONGITUDINAL STEEL BARS:
 *REPAIR AREAS MAY BE ADJUSTED AFTER REMOVING DISTRESSED CONCRETE. SWITCH THE HALF-DEPTH REPAIR TO FULL-DEPTH REPAIR IF EXPOSED EXISTING LONGITUDINAL BARS ARE DEFICIENT, AS APPROVED. COMPENSATION WILL BE MADE FOR UNEXPECTED VOLUMES OF REPAIR AREAS OR CHANGES IN SCOPE OF WORK.

*INCREASE THE REPAIR AREA AND PERFORM A FULL-DEPTH REPAIR AS DIRECTED IF LONGITUDINAL STEEL BARS WERE DAMAGED BY THE REMOVAL OPERATIONS. NO ADDITIONAL COMPENSATION WILL BE MADE.

SECTION A-A

HALF-DEPTH REPAIR

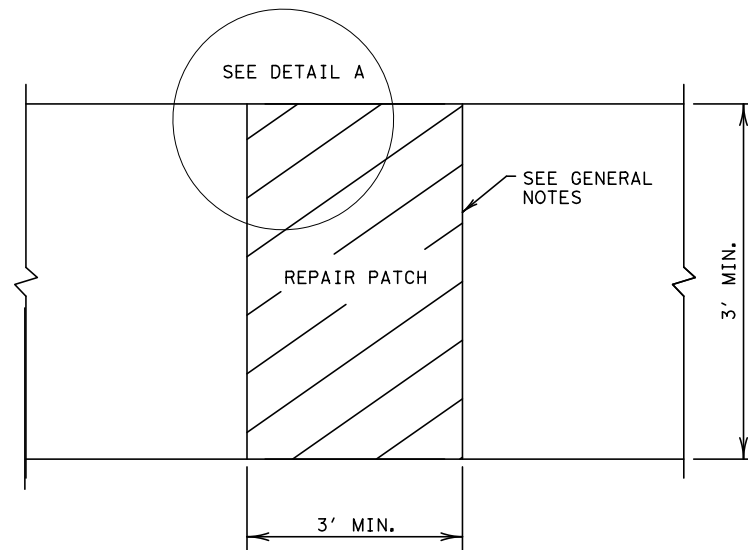

PLAN VIEW

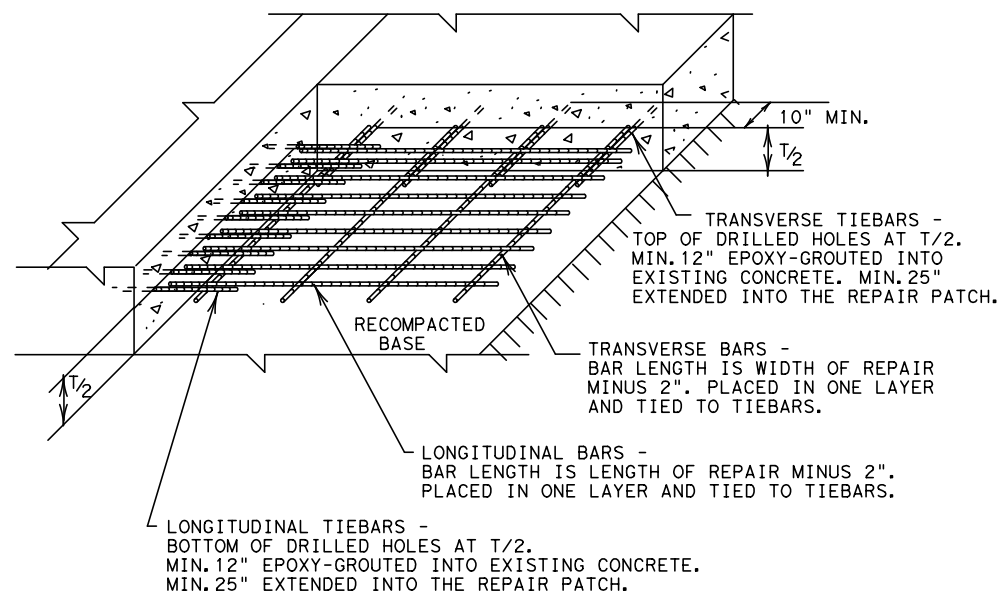

**DETAIL A
GROUTED TIEBARS & REINFORCEMENT**

FULL-DEPTH REPAIR OF CONCRETE PAVEMENT

GENERAL NOTES

1. MULTIPLE PIECE TIEBARS SHALL BE USED WHEN THE REPAIR AREA MUST BE PLACED IN TWO STAGES DUE TO SEQUENCE OF CONSTRUCTION.
2. FULL DEPTH SAW CUTS SHALL BE MADE AROUND THE PERIMETER OF THE AREA TO BE REPAIRED. THE CUT SHALL BE MADE AT A RIGHT ANGLE TO THE PAVEMENT EDGE AND TO THE CENTER LINE OF THE PAVEMENT.
3. AT LEAST ONE LONGITUDINAL FULL DEPTH SAW CUT SHALL BE AT AN EXISTING LONGITUDINAL JOINT.
4. ADDITIONAL SAW CUTS MAY BE REQUIRED WITHIN THE AREA OF THE REPAIR TO FACILITATE REMOVAL OF THE CONCRETE OR TO ALLEVIATE BINDING OF THE FULL DEPTH SAW CUT AT THE REPAIR EDGE.
5. THE SAW CUTS WHICH EXTEND OUTSIDE THE AREA OF THE REPAIR WILL BE CLEANED AND FILLED WITH A CEMENTITIOUS GROUT APPROVED BY THE ENGINEER.
6. EXISTING LONGITUDINAL AND TRANSVERSE JOINTS REMOVED DUE TO REPAIR OPERATION SHOULD BE RESTORED IN ACCORDANCE WITH STANDARD SHEET "EXPANSION JOINT REPAIR."
7. DOWEL BAR PLACEMENT TOLERANCE SHALL BE +/- 1/4 IN. HORIZONTALLY AND VERTICALLY UNLESS OTHERWISE SPECIFIED. WHERE DOWEL BAR BASKETS ARE USED, REMOVE THE SHIPPING WIRES.

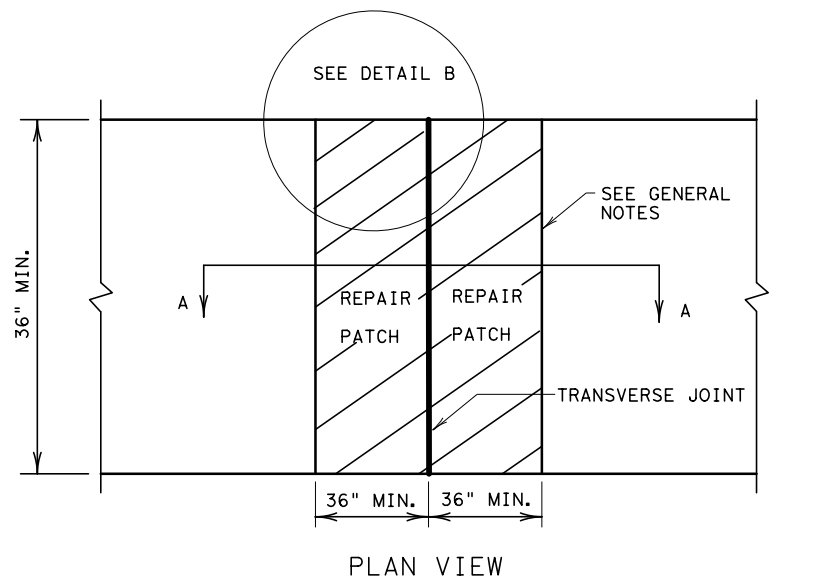

PLAN VIEW

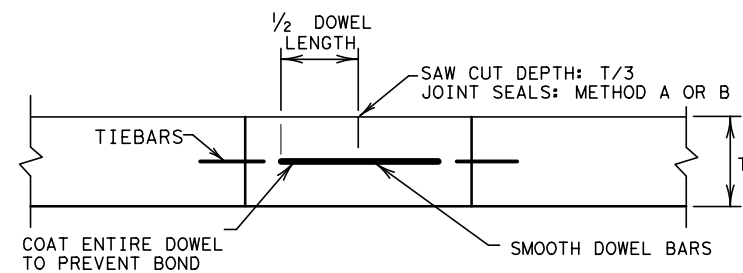

SECTION A-A

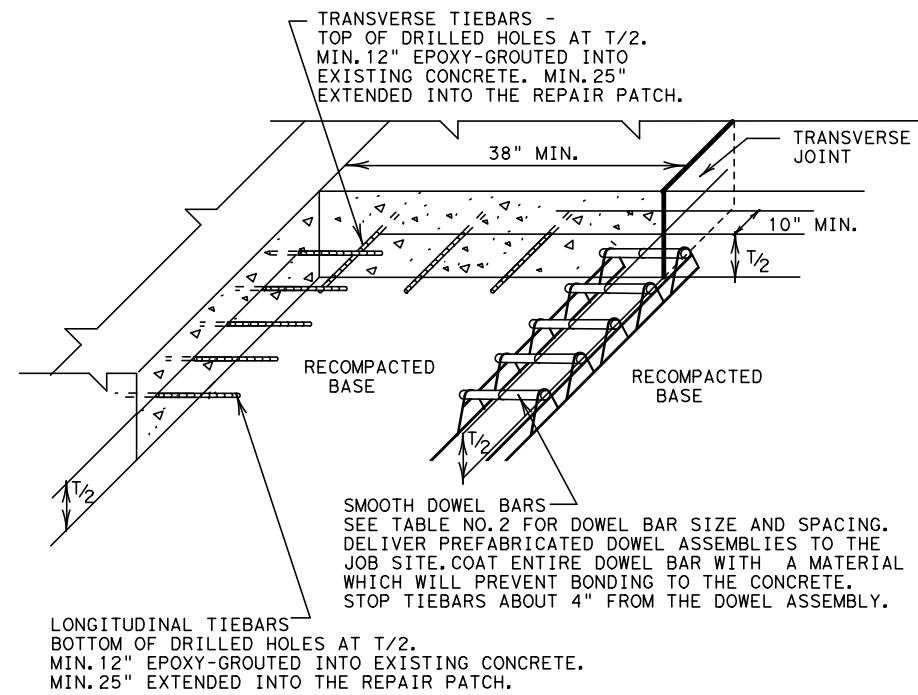

DETAIL B
GROUTED TIEBARS & DOWELS

TABLE NO. 2 DOWELS (SMOOTH BARS)			
PAVEMENT THICKNESS (INCHES)	SIZE AND DIA.	LENGTH (IN.)	SPACING (IN.)
<10	#8 (1 IN.)	20.0	12.0
≥10	#10 (1 1/4 IN.)		

REPAIR OF TRANSVERSE JOINT